

Ballast Box

Category 1

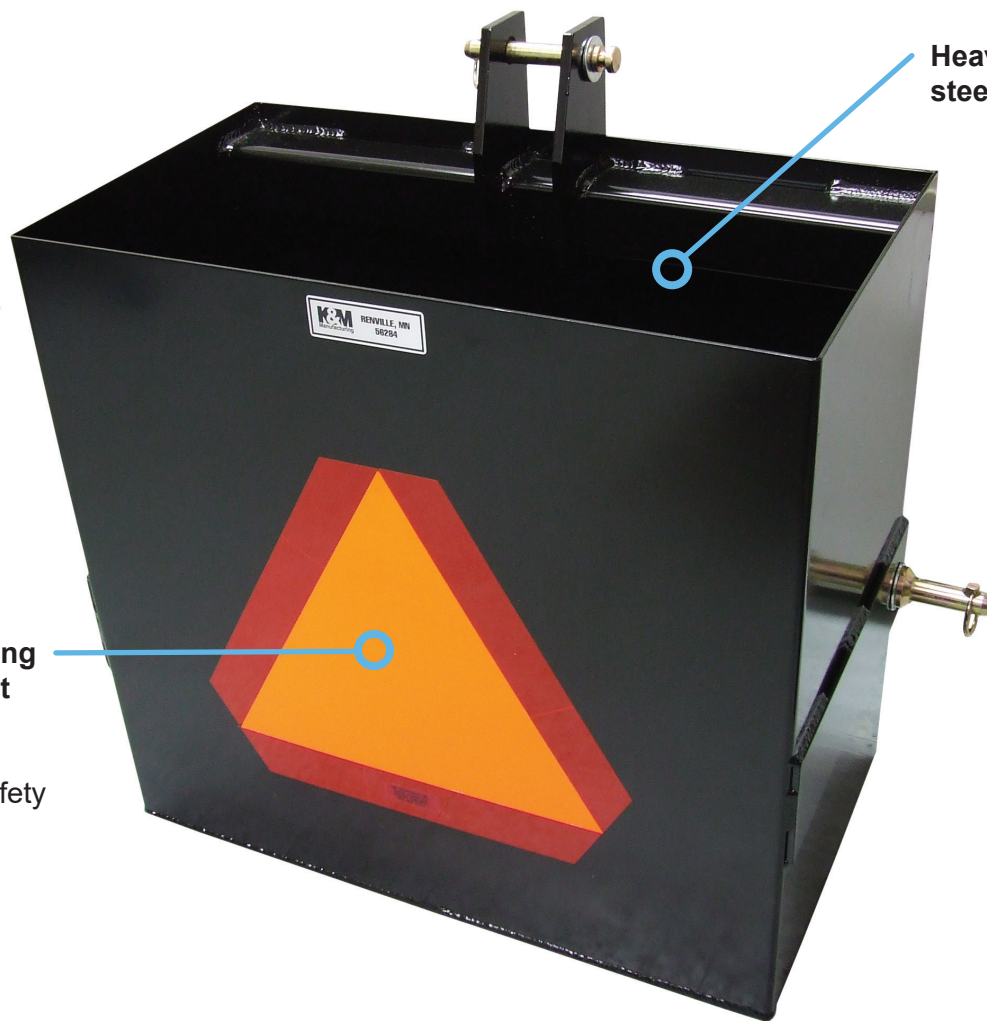

Black
PN: 1812



Heavy Gauge
steel construction

Includes slow-moving
vehicle emblem that
conforms to ASAE
S276.5 standards
ensuring operator safety

See **REVERSE**
for applications
and drawings.

- Easily connects to Category 1, 3-point hitch
- Best suited for 30-50 HP tractors
- 4.9 cubic foot capacity
- 113 lbs empty weight
- All hardware included

TRACTORS&EATS.com



800-328-1752

308 NW 2nd Street • Renville, MN 56284



APPLICATIONS



Tractors

REAR VIEW

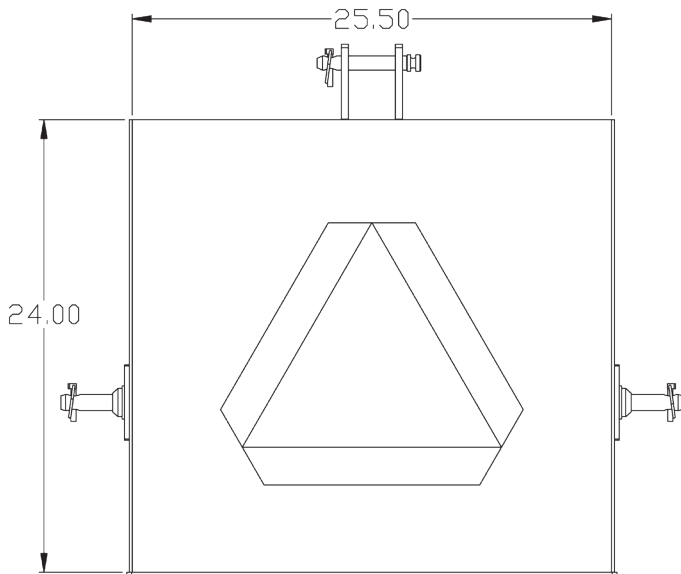

TOP VIEW

