

Installation Guide

JD 7R/8R-8RT/9R-9RX KM 1000 Air Seat Kit (PN: 6992)

1. Remove the Command Arm from the OEM seat and suspension. Keep the mounting hardware for later use.
2. Remove the OEM seat from the cab. Keep the mounting hardware for later use.
3. If the original seat was an Active Seat, plug hydraulic lines using the plugs provided.
4. Remove the OEM Command Arm Bracket from the OEM seat.
5. Install the swivel at this time using the instructions provided with the swivel kit. Be sure to leave the seat cushion off after the swivel is installed.
6. Remove the right hand armrest from the new seat.
7. Install the OEM Command Arm Bracket to the new seat. Reference the images below. If you have John Deere part RE269958 continue to step 8. If you have John Deere part RE576471, go to step 10 on page 3.
8. Install John Deere part RE269958 using two 5/16" x 3/4" bolts and serrated flange nuts, two 8mm flange nuts, and one 3/8" x 1" bolt with two flat washers and a serrated flange nut. Reference the image on page 2 for more detail.
9. Reinstall the seat cushion. Continue to step 12 on page 5.

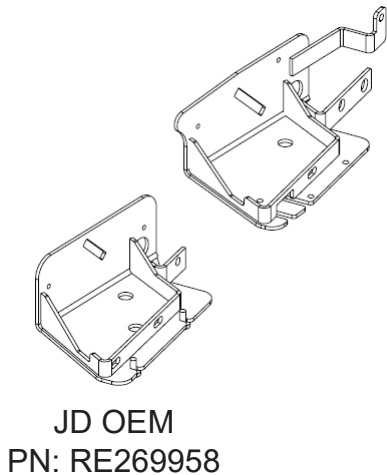

JD OEM
PN: RE576471

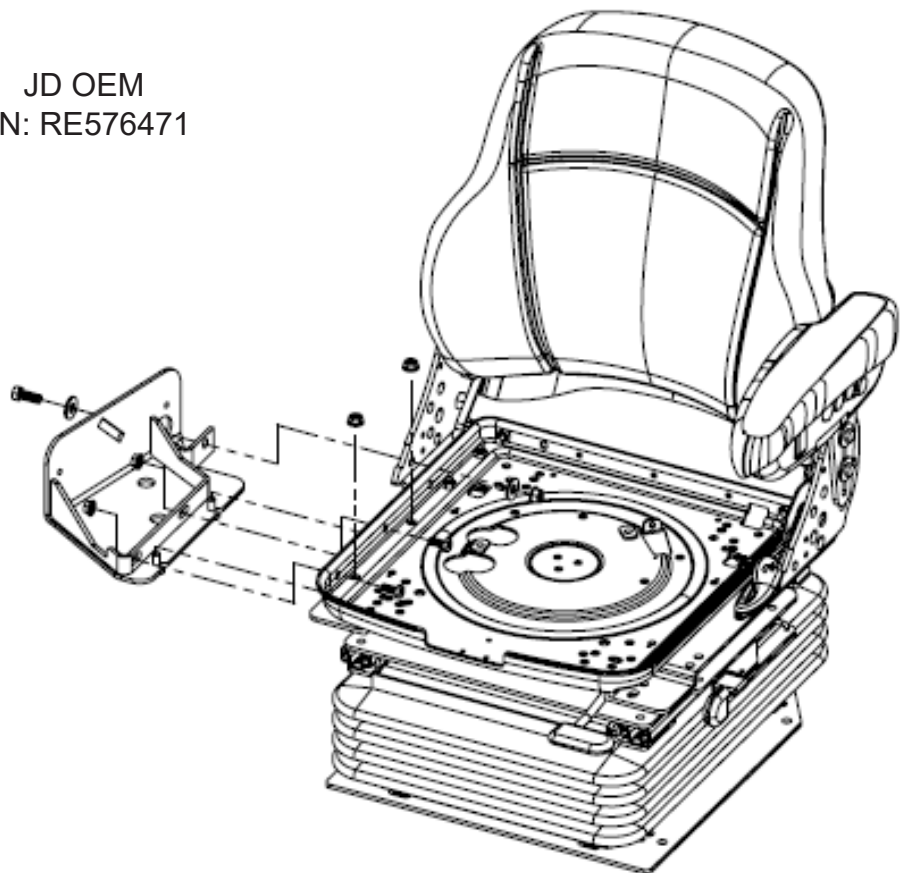

Installation Guide

JD 7R/8R-8RT/9R-9RX KM 1000 Air Seat Kit (PN: 6992)

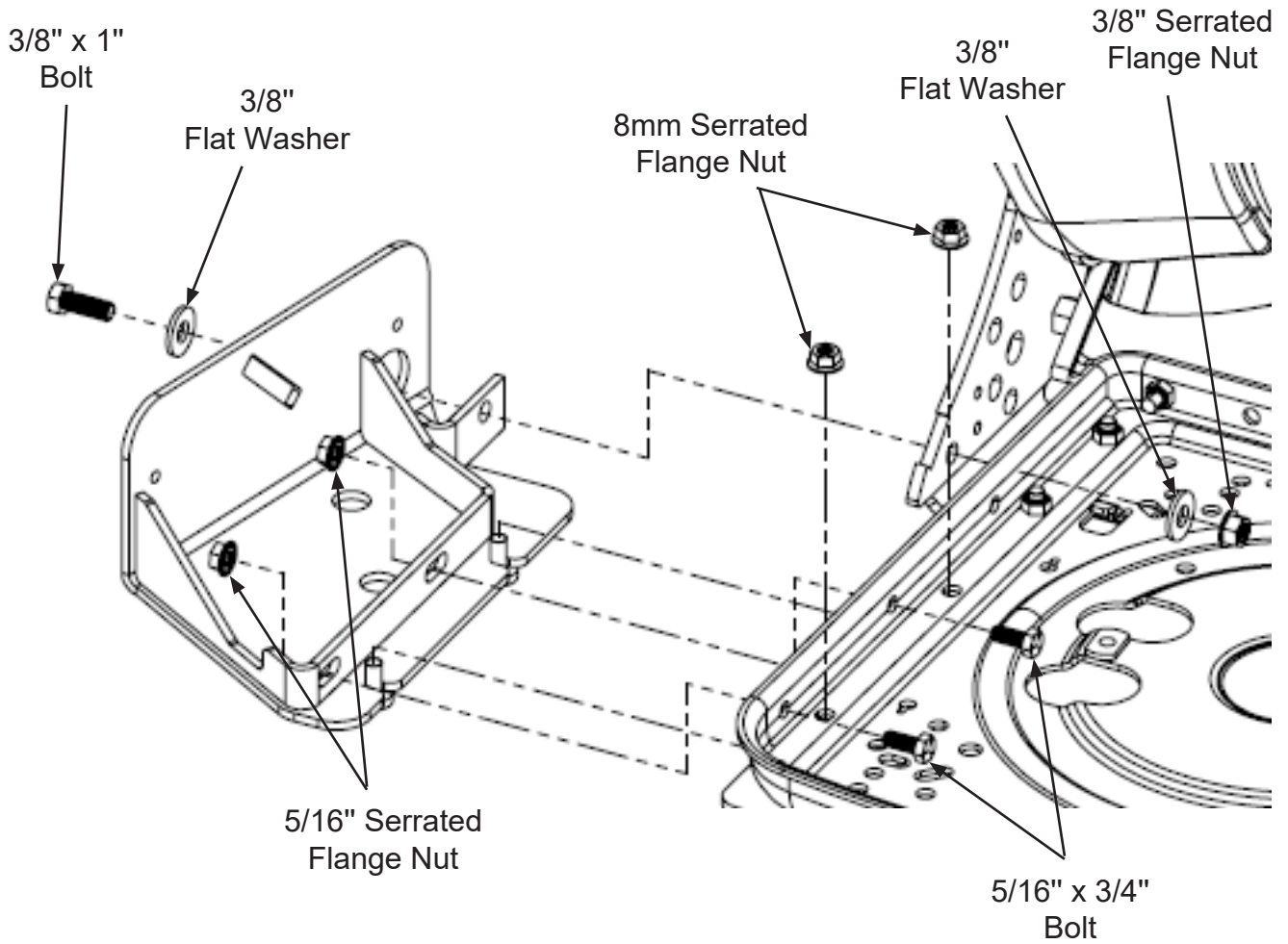

Installation Guide

JD 7R/8R-8RT/9R-9RX KM 1000 Air Seat Kit (PN: 6992)

10. Install John Deere part RE576471 using two 5/16" x 3/4" bolts and serrated flange nuts, one 3/8" x 1" bolt with two flat washers and a serrated flange nut, and one bolt and washer from the right hand armrest that was removed. Reference the image on page 4 for more detail.

11. Reinstall the seat cushion.

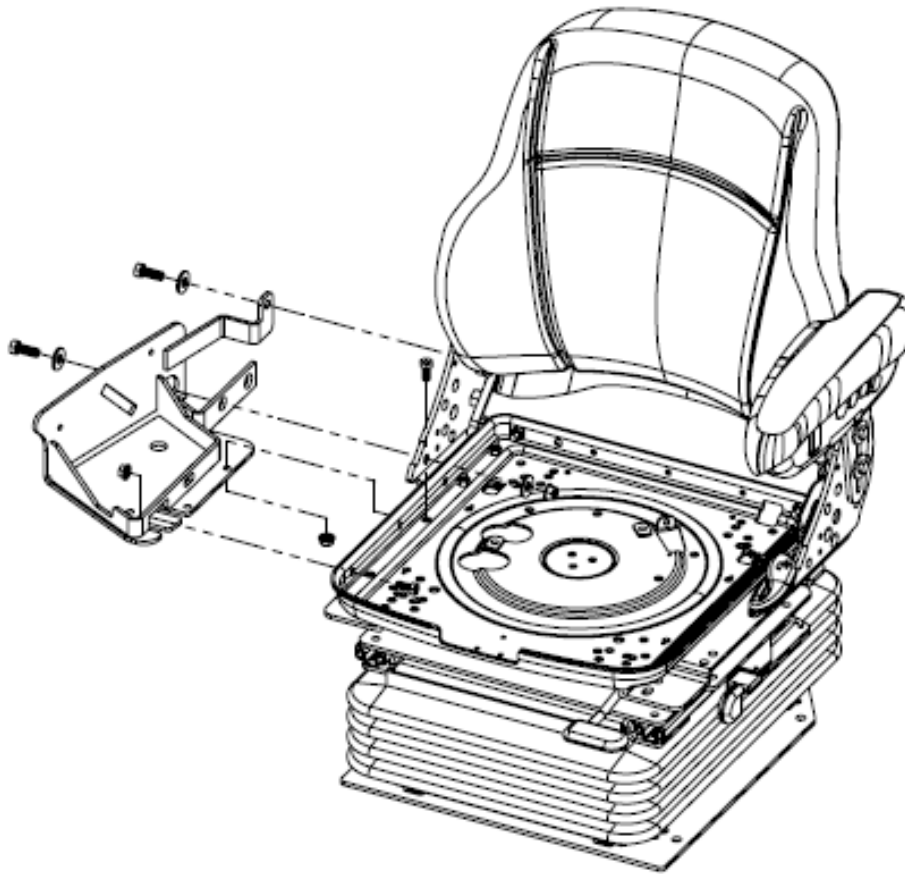

Installation Guide

JD 7R/8R-8RT/9R-9RX KM 1000 Air Seat Kit (PN: 6992)

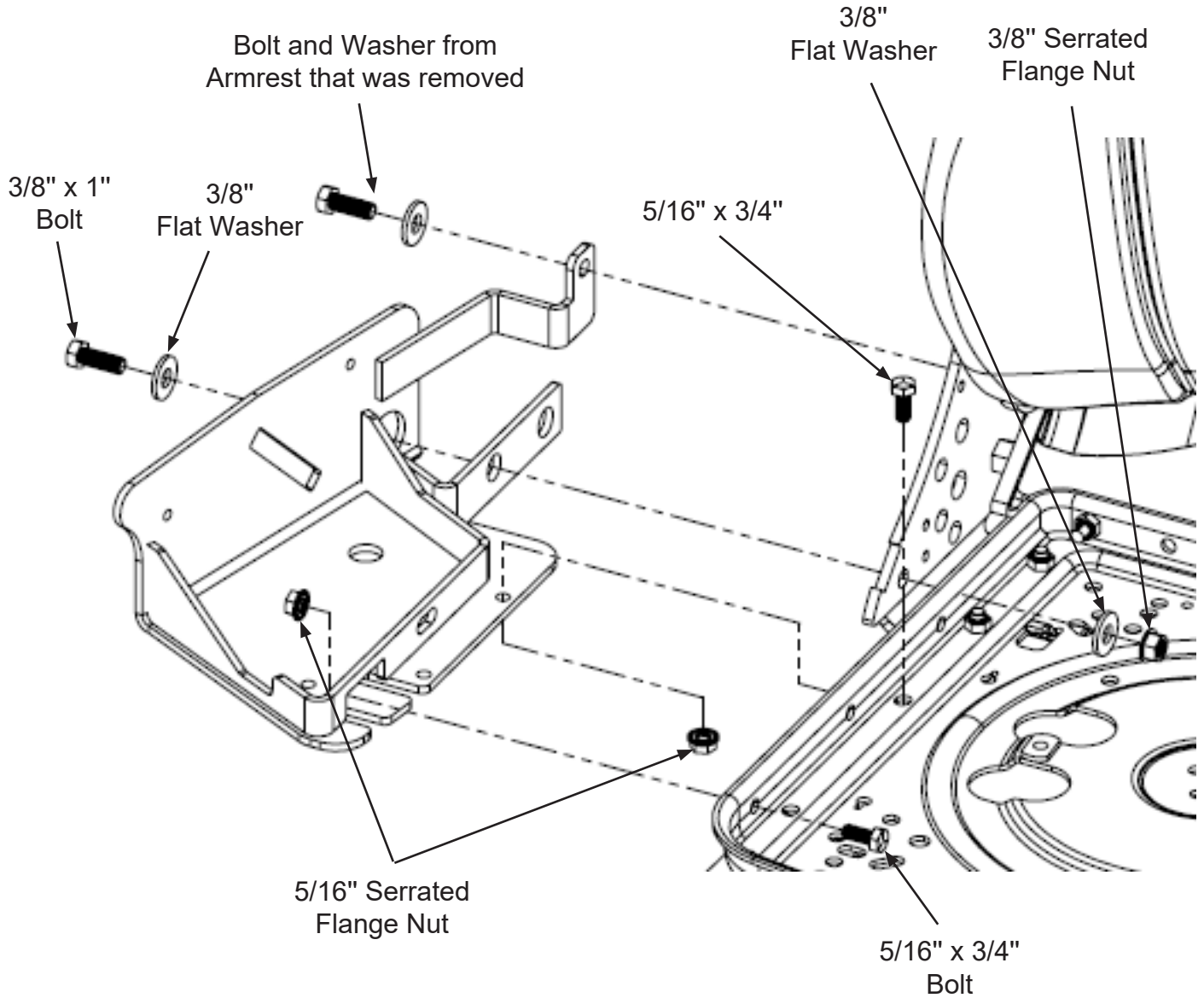

Installation Guide

JD 7R/8R-8RT/9R-9RX KM 1000 Air Seat Kit (PN: 6992)

12. Mount the 6077 PED plate to the bottom of the suspension using four 8mm x 20mm flat head socket cap screws.
13. Install the seat assembly into the tractor. Fasten in place using the original mounting hardware.
NOTE: You may have to move the OEM clip nuts on the OEM seat support to other mounting holes as the seat assembly may cover up the original ones used.
14. Mount the Command Arm to the seat assembly using the original hardware.
15. Connect the seat wiring to the cab wiring using the harness provided in the kit.

