

Installation Guide

JD 30 Early KM 402 Sound-Gard™ Air Seat Kit (PN: 6954)

1. Remove the original seat and suspension. Keep the hardware holding the seat and suspension to the back of the cab.
2. Cut out 4 1/2" of cab metal from the left side of the existing seat well cavity. (Use of a Sawzall is recommended.)
3. Place the seat well extension kit (SWEK) into the opening from the bottom side of the cab and fasten with the sheet metal screws provided. Use a 5/32" drill bit for the holes.
4. Once installed, you may want to run a bead of caulking around the edges of the SWEK and the seat well to seal the cab up and keep dust out.

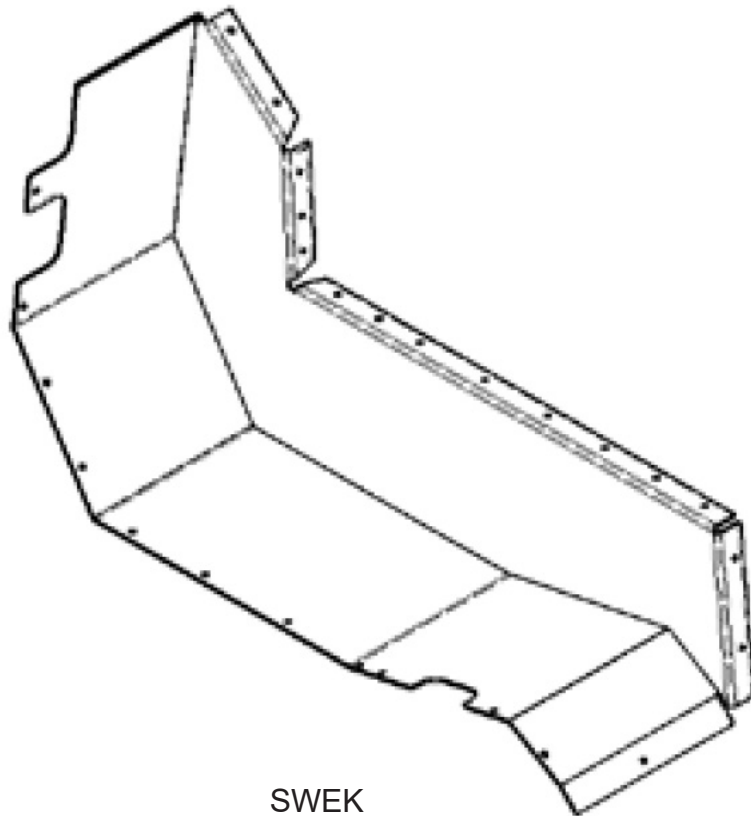

SWEK
PN: 6052

Installation Guide

JD 30 Early KM 402 Sound-Gard™ Air Seat Kit (PN: 6954)

1. For the models that have the slanted front section, use the W43A plate. For models that have the square front section, use the W43B plate.
2. Bolt the corresponding plate to the bottom of the 6051 Plate using two 5/16" x 3/4" carriage bolts and flange nuts. Hand tighten only.
3. Place the assembly in the seat well and bolt in place to the back of the cab using the original hardware. Slide the W43A or W43B plate tight to the seat well. Mark the locations of the front two holes on the W43A or W43B plate and drill through the seat well using an 11/32" drill bit.
4. Remove the assembly making sure the W43A or W43B plate does not shift and tighten the bolts holding the W43A or W43B plate.

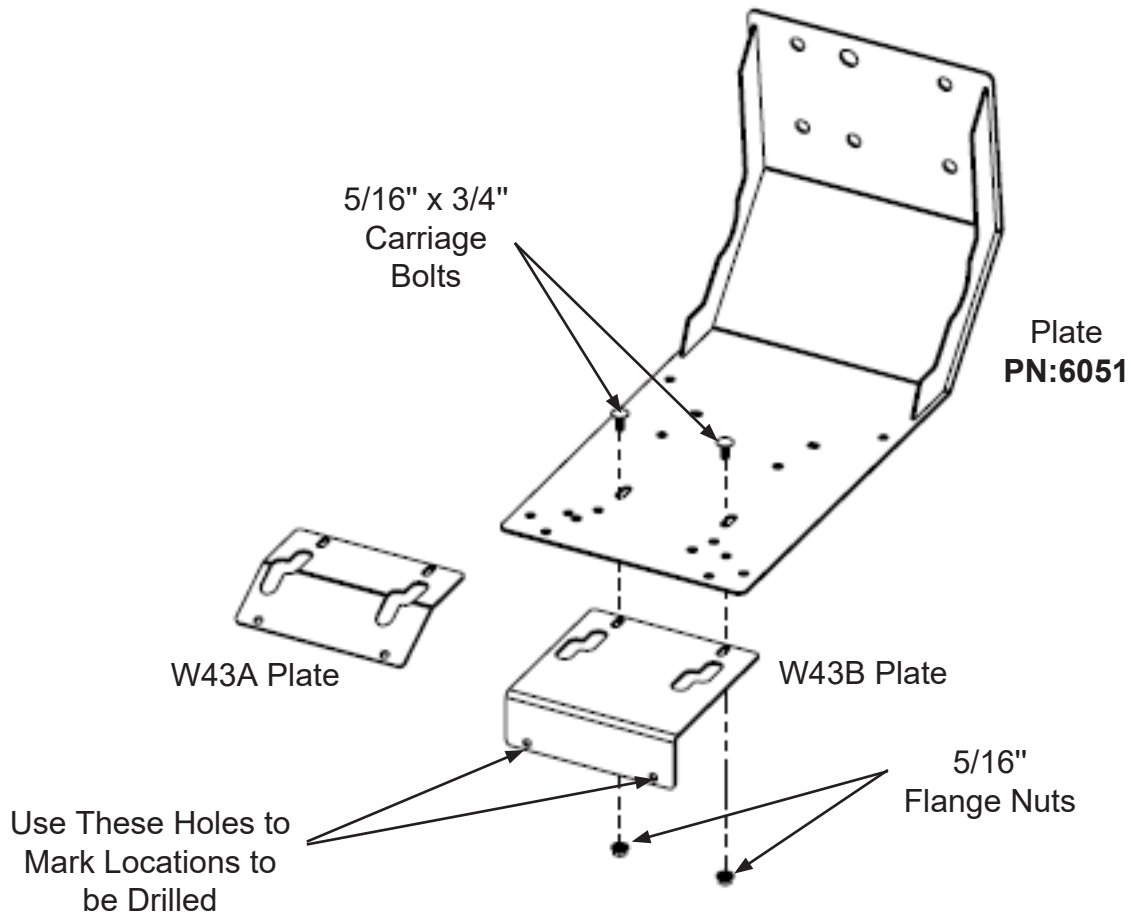

Installation Guide

JD 30 Early KM 402 Sound-Gard™ Air Seat Kit (PN: 6954)

1. Mount the suspension to the 6051 plate using four 5/16" x 3/4" socket head bolts, spacer bushings, and flange nuts. The spacer bushings go in between the suspension and the 6051 plate. You will have to loosen the rubber boot around the bottom of the suspension to get the bolts in.
2. Mark the front of the slide rails for later reference. Remove the slide rails from the bottom of the seat. Keep the hardware.
3. Separate the upper and lower halves of the slide rails. Mount the lower halves of the slide rails to the suspension using four 8mm x 12mm low head socket cap screws. Make sure the front of the slide rails go to the front of the suspension. Hand tighten only.

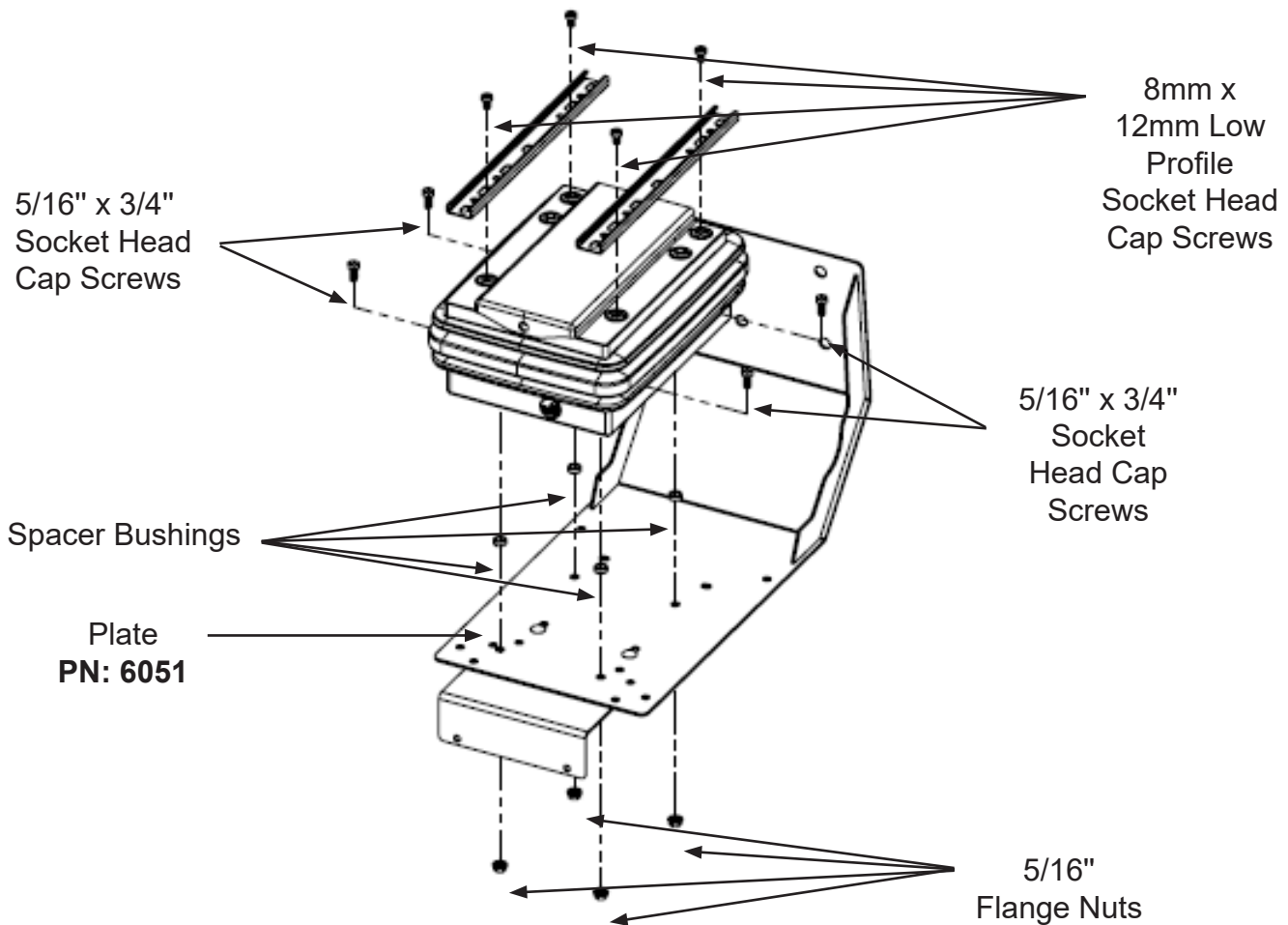

Installation Guide

JD 30 Early KM 402 Sound-Gard™ Air Seat Kit (PN: 6954)

1. Fasten the upper halves of the slide rails to the 6141 plate using four 5/16" x 1/2" flat head socket cap screws and jam nuts.
2. Apply a small amount of grease to the bottom and sides of the upper slide rail halves.
3. Slide the 6141 and upper slide rails from the front onto the suspension. Be sure to pull the slide rail adjustment handle out to allow assembly to go on.
4. Tighten the four 8mm bolts holding the lower slide rails to the suspension.
NOTE: Leave the 6141 plate and upper slide rails attached to the lower slide rails. Adjust the 6141 and slide rail assembly as necessary to tighten the bolts. There are holes at the front of the 6141 plate to allow access to the front 8mm bolts.

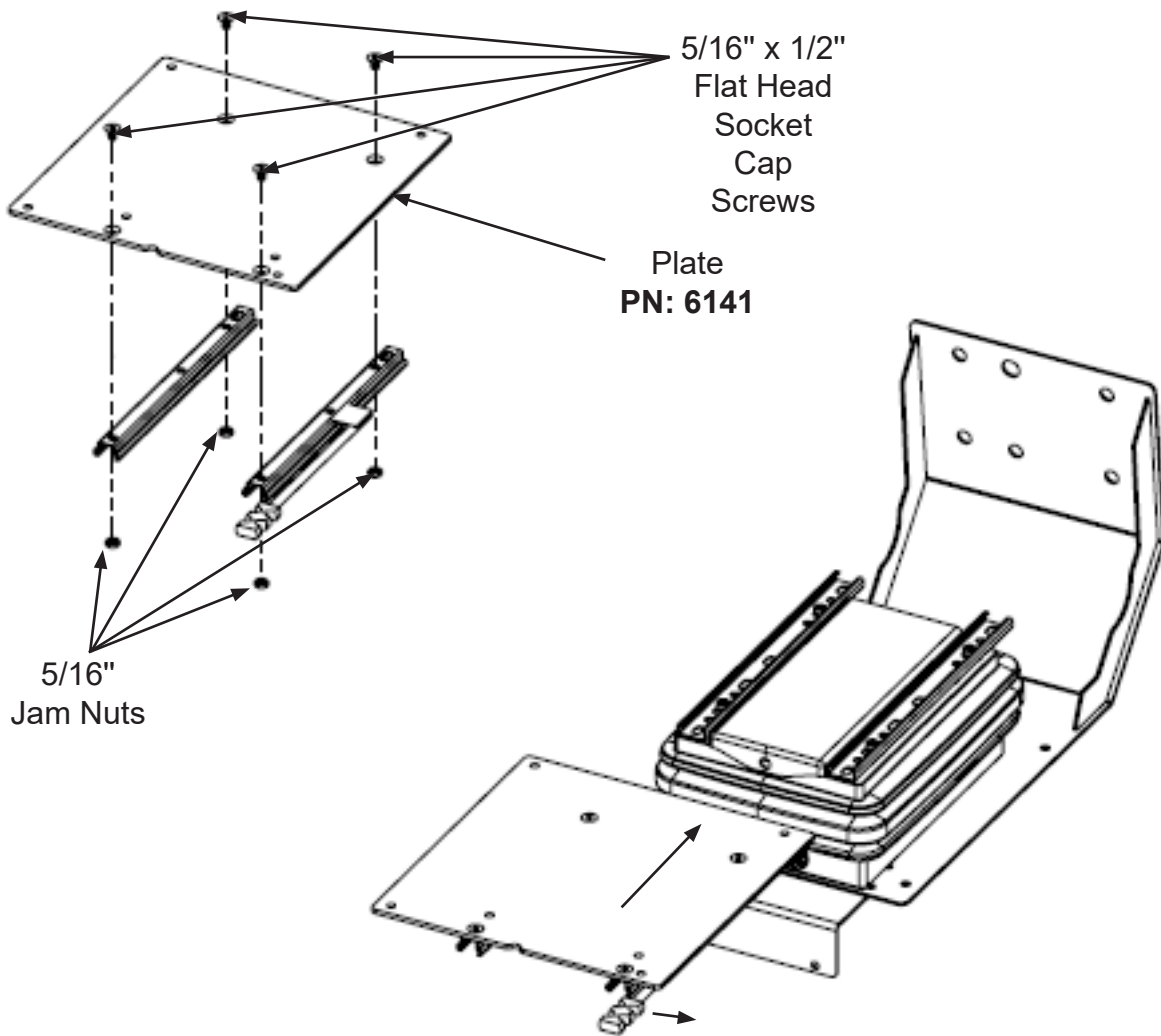

JD 30 Early KM 402 Sound-Gard™ Air Seat Kit (PN: 6954)

1. Place the suspension assembly into the tractor and mount to the back of the cab using the original bolts. Fasten the W43A or W43B plate to the seat well using two 5/16" x 3/4" bolts and flange nuts. You will have to reach under the cab to get the nuts in place.
2. Rotate the swivel 45 degrees to allow easier access to the holes. Mount the swivel to the bottom of the seat using the hardware that held the slide rails to the bottom of the seat. Be sure to center the seat from side to side on the swivel before tightening the hardware.

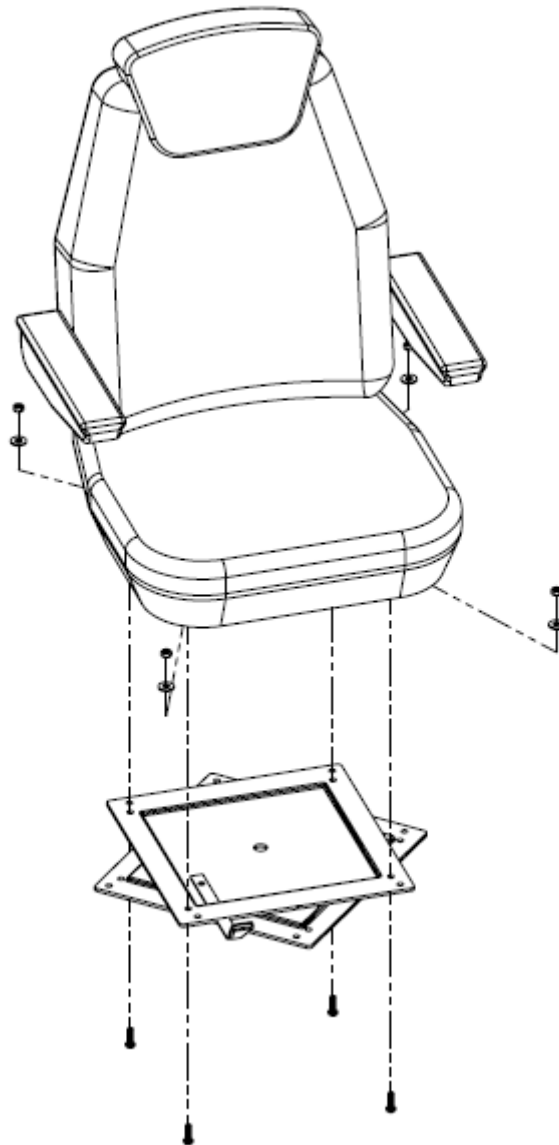

Installation Guide

JD 30 Early KM 402 Sound-Gard™ Air Seat Kit (PN: 6954)

1. Place the seat and swivel assembly in the cab and fasten to the suspension assembly using four 5/16" x 3/4" button head socket cap screws and flange nuts.
2. If the suspension is an air suspension, connect the wires to a power and ground source. Keyed power is recommended.

