

Installation Guide

CIH Mag, MX, Steiger, STX-KM 1061 Kit (PN: 6908 & 6909)

1. Remove the OEM seat and suspension. Be sure to keep the four 8mm flange nuts that held the seat and suspension to the floor. They will be reused.
2. Remove the seat top from the new suspension. Use the additional instruction guide or go to this link (<http://bit.ly/2AJfthi>) for a video on how to remove it.
3. Remove the right hand armrest from the seat top. To do so, remove the plastic cover and remove the nuts holding it on. The armrest can be discarded.
4. Fasten the 6945 Plate to the bottom of the suspension using four 5/16" x 3/4" flat head socket cap screws and 5/16" flange nuts. The notch in the plate goes to the front of the suspension.

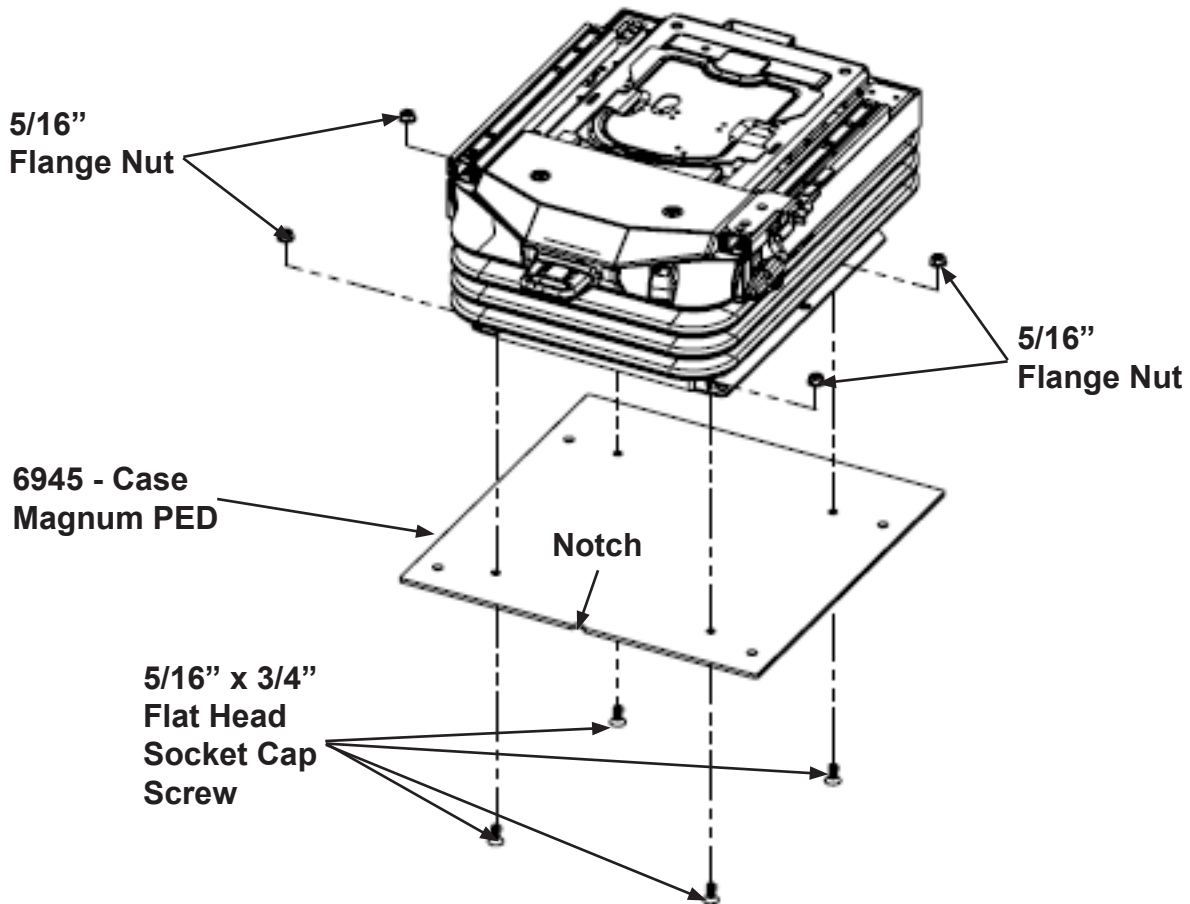

Installation Guide

CIH Mag, MX, Steiger, STX-KM 1061 Kit (PN: 6908 & 6909)

1. Rotate the swivel 45 degrees as shown.
2. Remove the plastic knock outs from the swivel on both halves (8 total). The front two corners and the second holes from the back. See diagram below for more clarity. The arrows point to the knock outs that need to be removed.
3. Use three 5/16" washers as spacers to level the swivel on the slide rails. Install one on the second from the front hole on the right slide rail and one each on the rear holes of each slide rail.
4. Place the swivel on top of the slide rails and fasten down with four 5/16" x 3/4" button head socket cap screws and four 5/16" center lock nuts. NOTE: You will have to adjust the slide rails forward and backwards to get the nuts on.
5. Place the suspension and swivel assembly into the cab and mount to the floor using the original 8mm flange nuts.

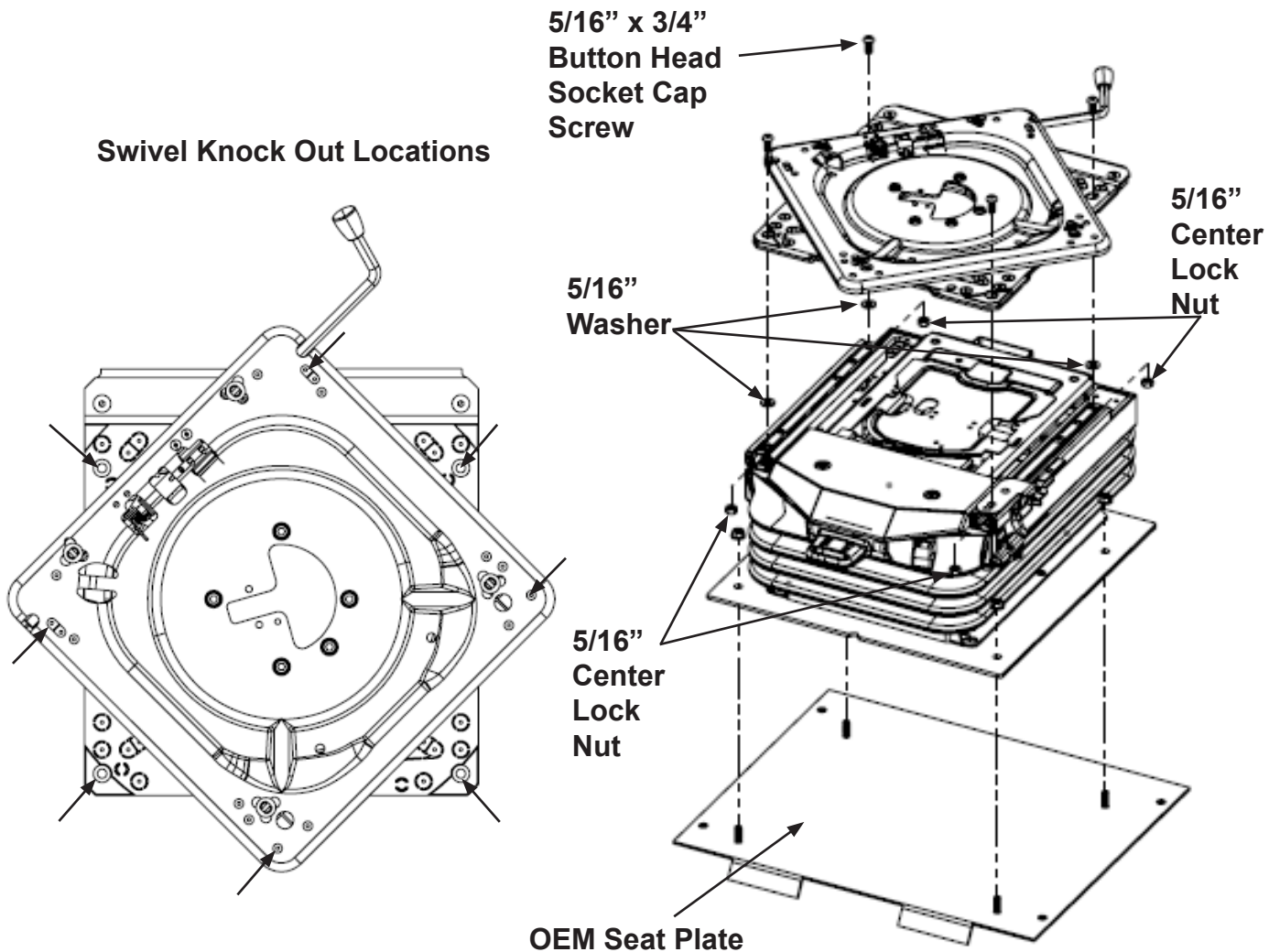

1. Check the command arm mount bracket in your cab and verify which bracket you have. See below for the four different options. NOTE: The plastic housing is not shown for clarity.
2. Use the corresponding K&M bracket and hardware in the following pages to assemble the plate and bracket mounting.

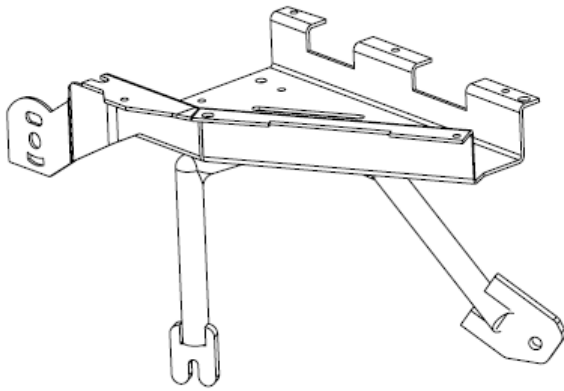

Command Arm Bracket A

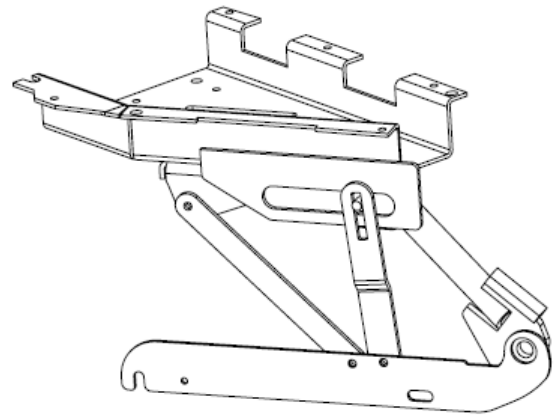

Command Arm Bracket B

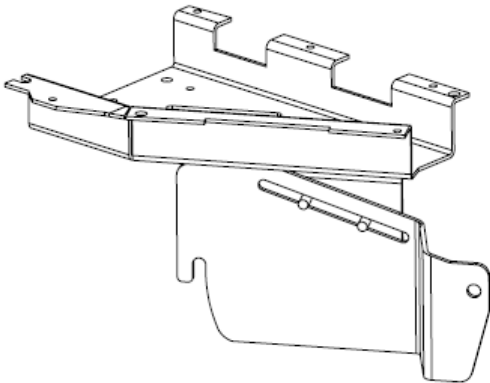

Command Arm Bracket C

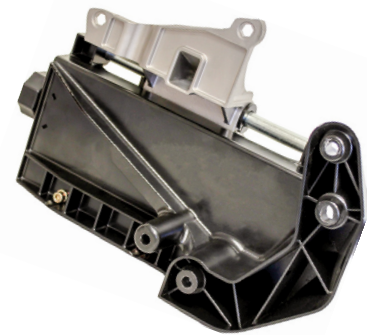

Command Arm Bracket D

For Command Arm Brackets A&B

1. Attach the 6943 bracket to the 6946 plate using two 5/16" x 1 3/4" flat head socket cap screws, two 5/16" x 3/4" hex bolts, two 1" spacers, and four 5/16" flange nuts as shown below.
2. The 7/16" x 1 1/2" hex bolt, 5/16" x 1 1/4" hex bolt, and 3/8" spacer are used to mount your command arm to the assembly. This will be done after the seat is installed in the cab. The spacer is only used for the A style command arm. It goes in between the command arm and the 6943 bracket.
3. Go to Page 7 for seat installation.

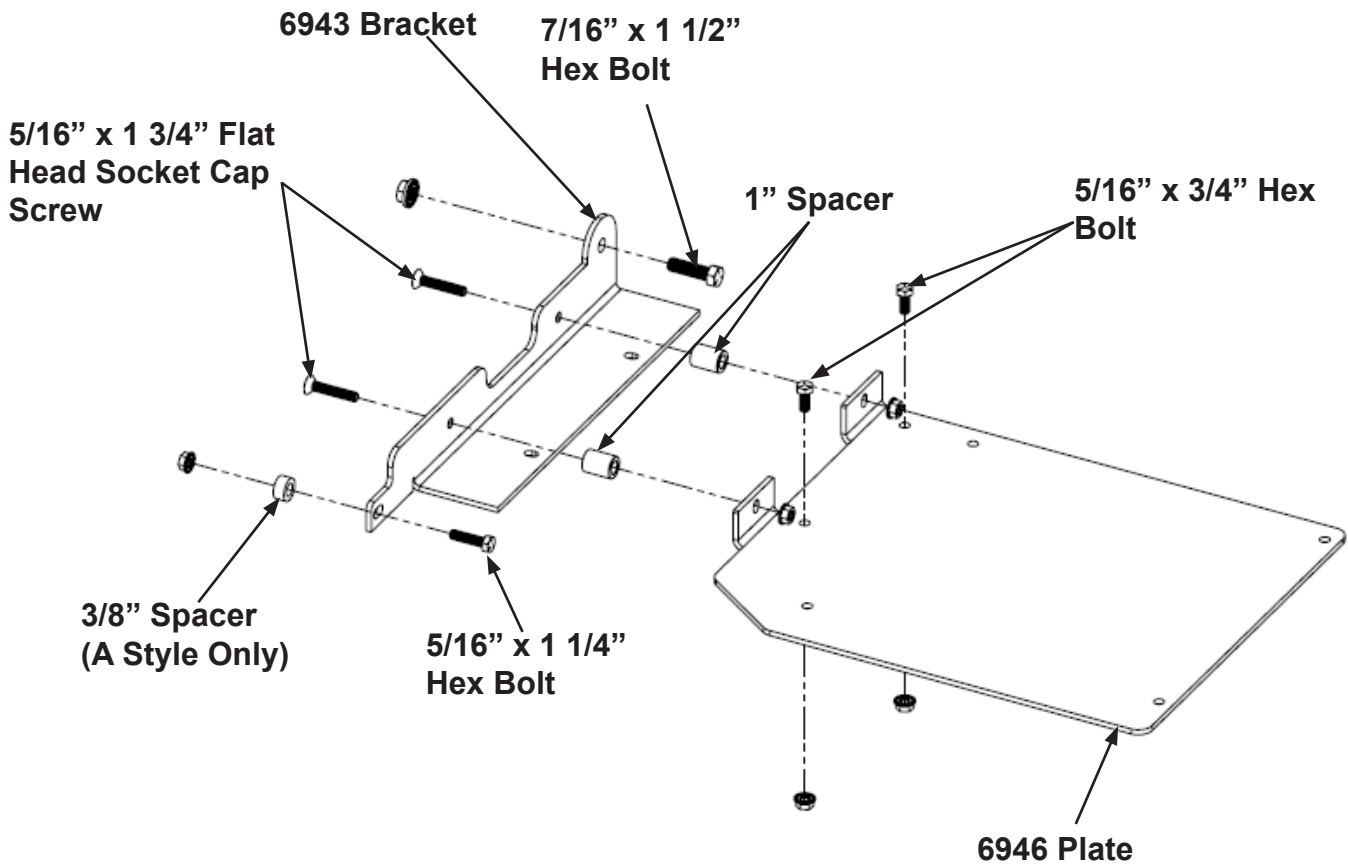

For Command Arm Bracket C

1. Attach the 6944 bracket to the 6946 plate using two 5/16" x 1 3/4" flat head socket cap screws, two 5/16" x 3/4" hex bolts, two 1" spacers, and four 5/16" flange nuts as shown below.
2. The 7/16" x 1" hex bolt, 3/8" x 3 1/2" hex bolt, and 2 1/2" spacer are used to mount the command arm to the assembly. This will be done after the seat is installed in the cab. The spacer goes in between the command arm and 6944 bracket.
3. Go to Page 7 for seat installation.

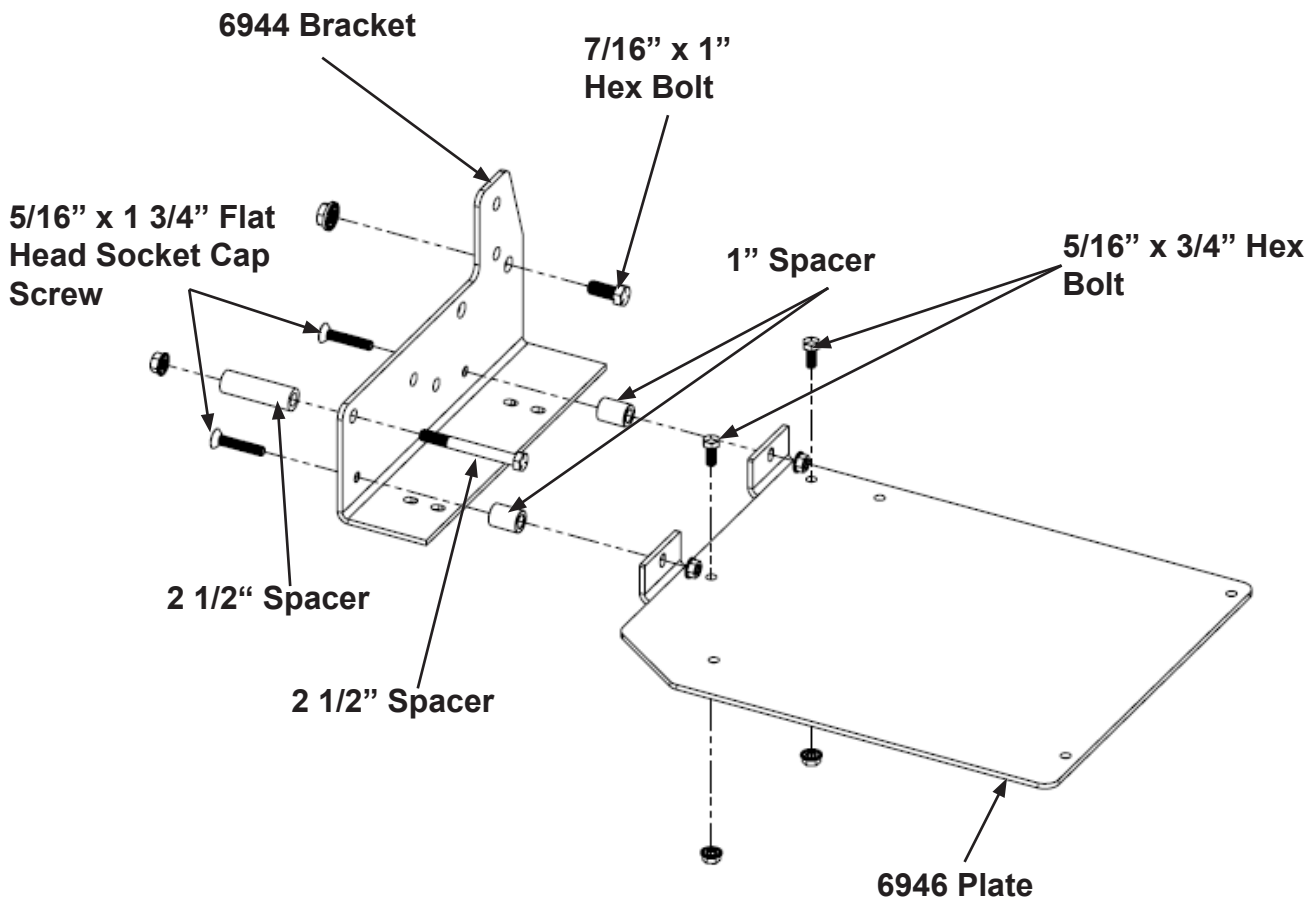

For Command Arm Bracket D

1. Attach the 6944 Bracket to the 6946 Plate using two 5/16" x 3/4" flat head socket cap screws, two 5/16" x 3/4" hex bolts, and four flange nuts as shown below.
2. The four 5/16" x 1 1/4" socket cap screws are used to mount your command arm to the assembly. They will not be used until after the seat is installed in the cab.
3. Go to Page 7 for seat installation.

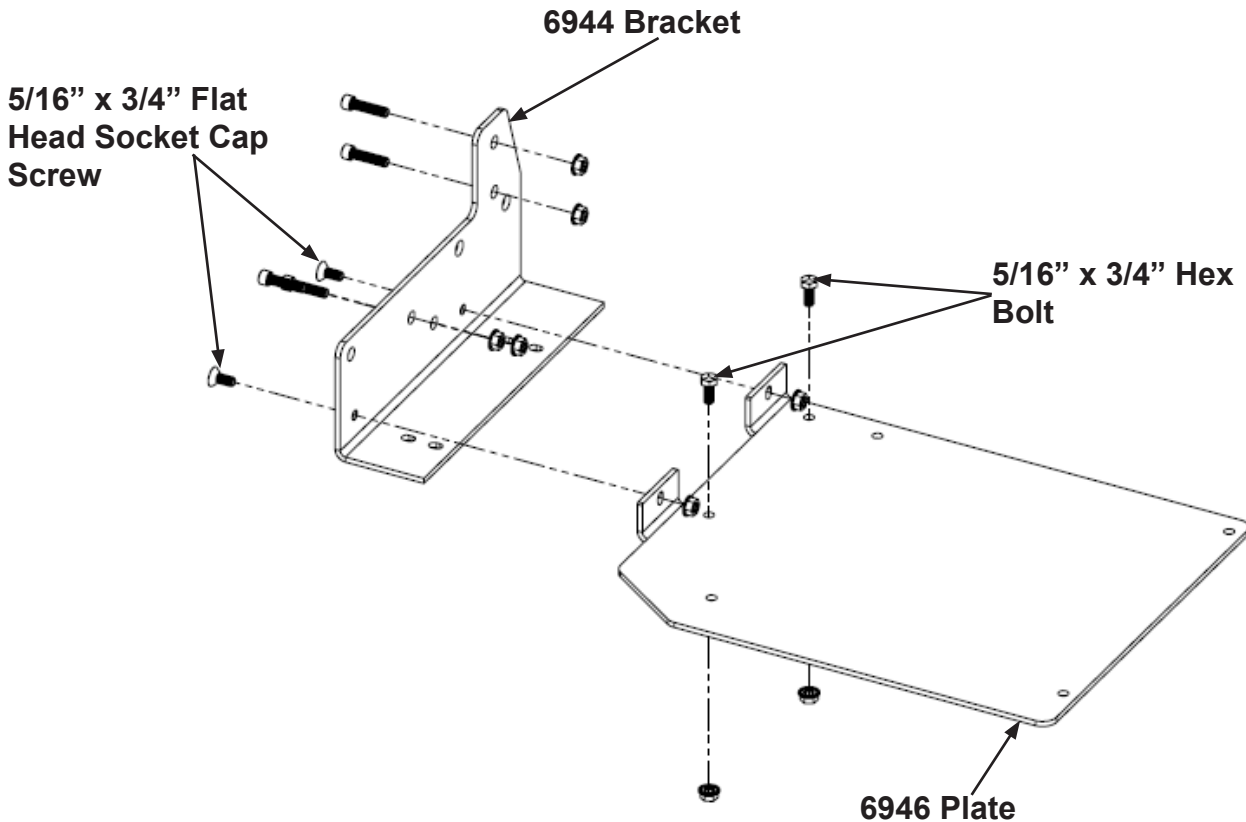

Installation Guide

CIH Mag, MX, Steiger, STX-KM 1061 Kit (PN: 6908 & 6909)

1. Place the comand arm mount bracket assembly and seat on top of the swivel. You will have to rotate the swivel 45 degrees to install the bolts.
2. Fasten using four 5/16" x 3/4" button head socket cap screws and flange nuts. The bolts run up through the swivel.
3. Mount your command arm to the command arm bracket. Use the hardware as described on the previous pages for your particular command arm mount.
4. Re-install the seat cushion and components in the reverse order they were taken apart. (Reference the additional install guide).

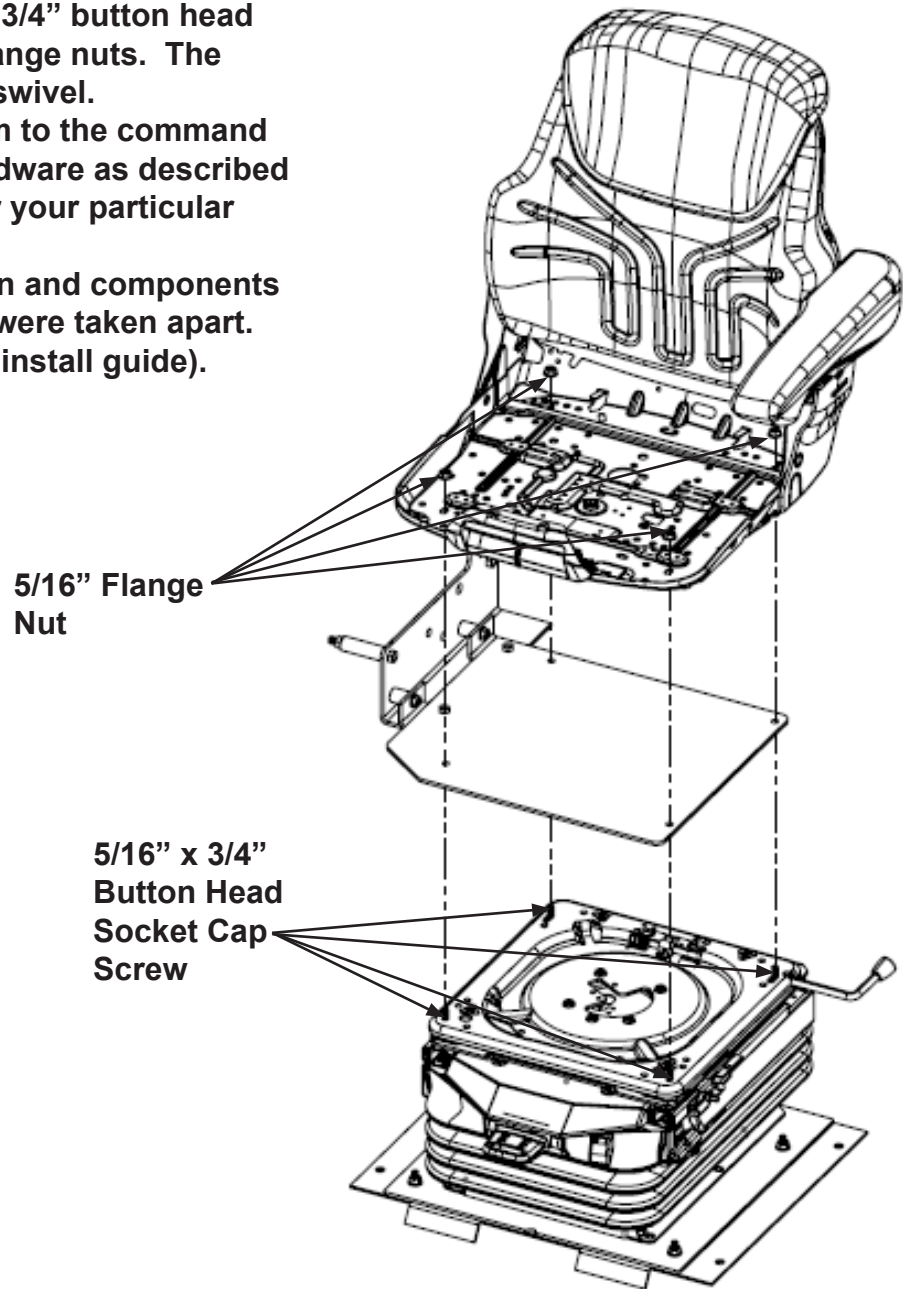



Installation Guide

CIH Mag, MX, Steiger, STX-KM 1061 Kit (PN: 6908 & 6909)

1. Connect the Operator Presence Switch connector from the seat and the power supply connector from the suspension to the harness included in the install kit. Connect the other end to the tractor connector in the cab.