



Installation Guide

KM 402 Kit Air/Mech Installation (PN: 6795 & 6796)

1. Remove original seat and suspension from the cab.
2. Cap the hydraulic lines with the nuts and plugs provided. Cut and plug the breather line by turning a 5/16" x 1" bolt into the tube.
3. Remove and discard the slide rails that come attached to the new seat.

Installation Guide

KM 402 Kit Air/Mech Installation (PN: 6795 & 6796)

4. Bolt the 6048 slide rails to the suspension using four 8mm x 12mm low profile socket cap screws. The slide rail must be assembled with the adjustment lever to the left side of the seat and suspension.

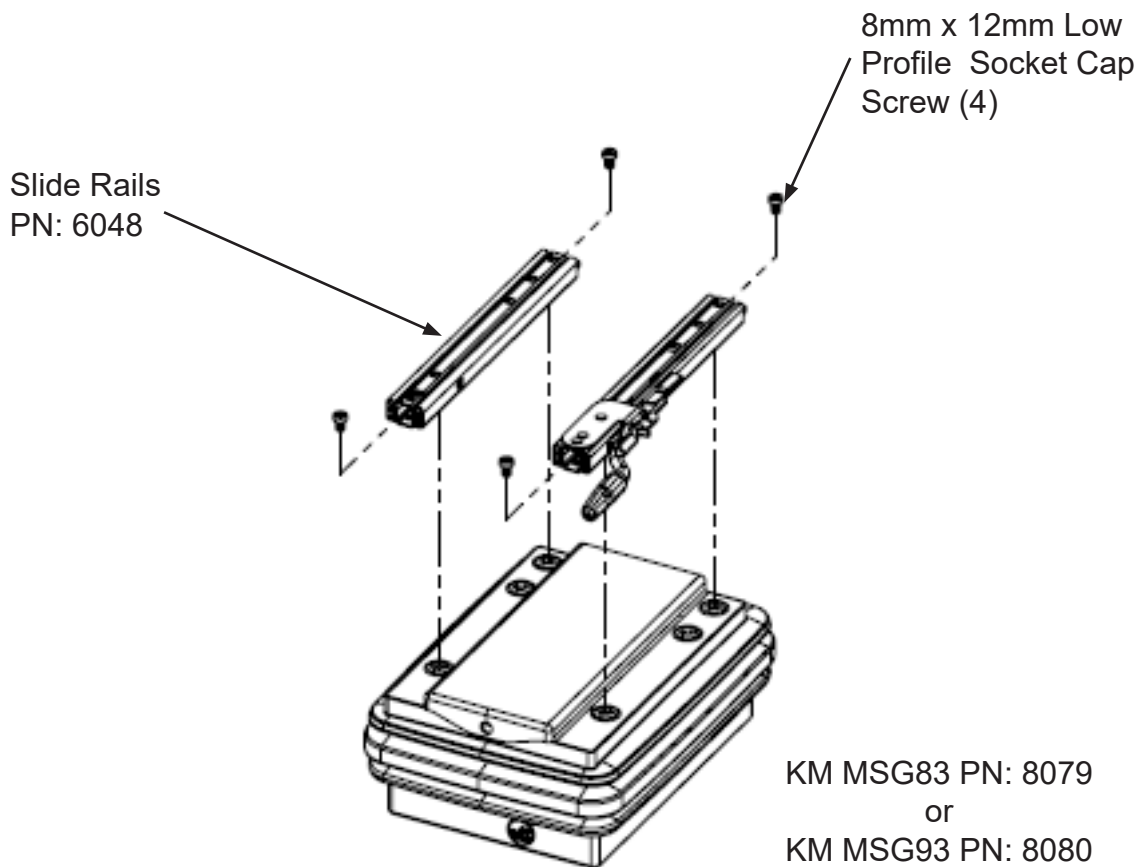

Installation Guide

KM 402 Kit Air/Mech Installation (PN: 6795 & 6796)

5. Bolt the 6080 SAP to the slide rails using four 5/16" x 3/4" flat head socket cap screws, three flat washers, and four 5/16" jam nuts. The three flat washers go in between the 6080 SAP and the slide rails as shown below.

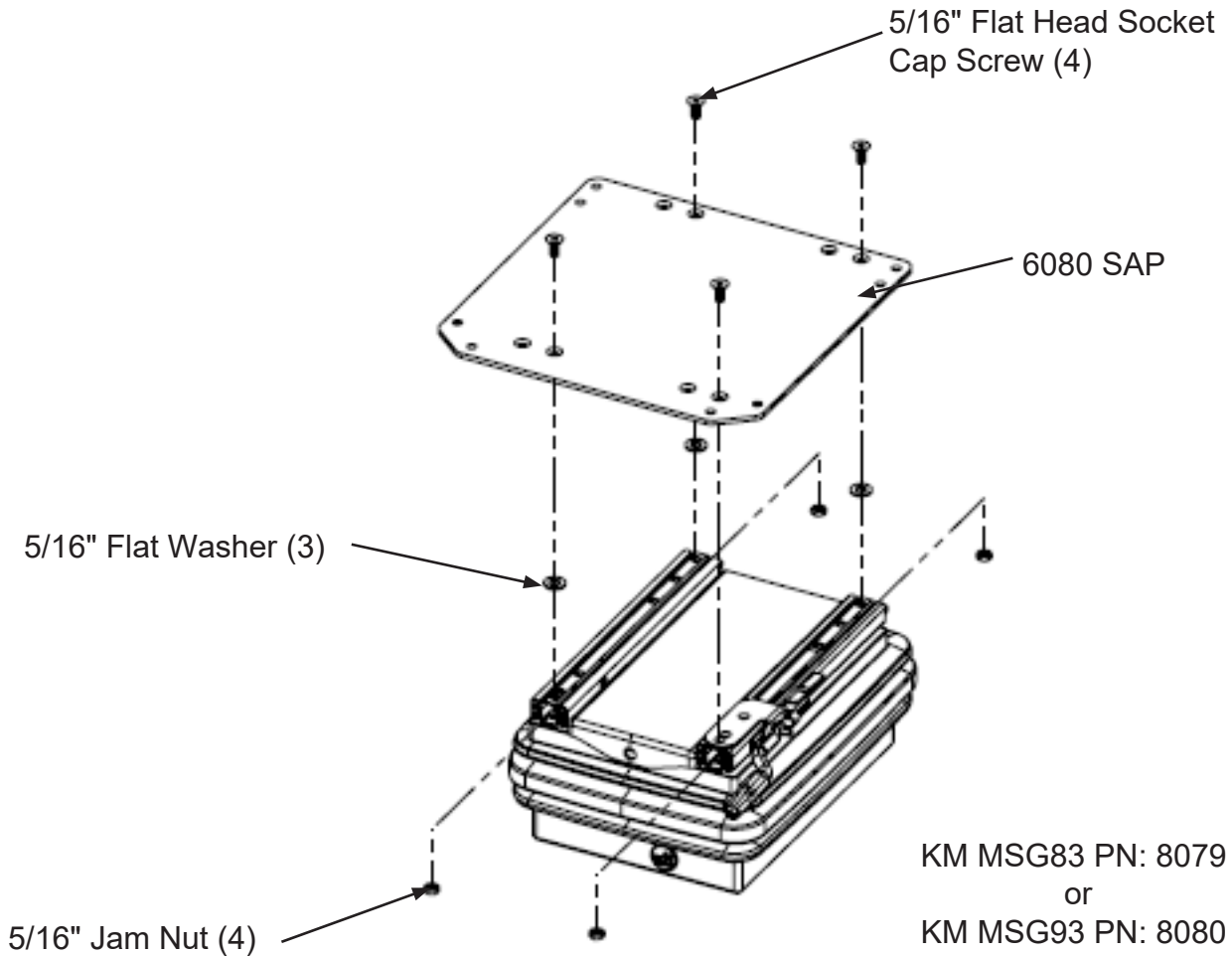

Installation Guide

KM 402 Kit Air/Mech Installation (PN: 6795 & 6796)

6. Bolt the suspension to the JD PED 44 using four 5/16" x 5/8" bolts and serrated flange nuts. You will have to loosen the lower part of the rubber bellows to access the inside of the suspension to get the nuts onto the bolts.

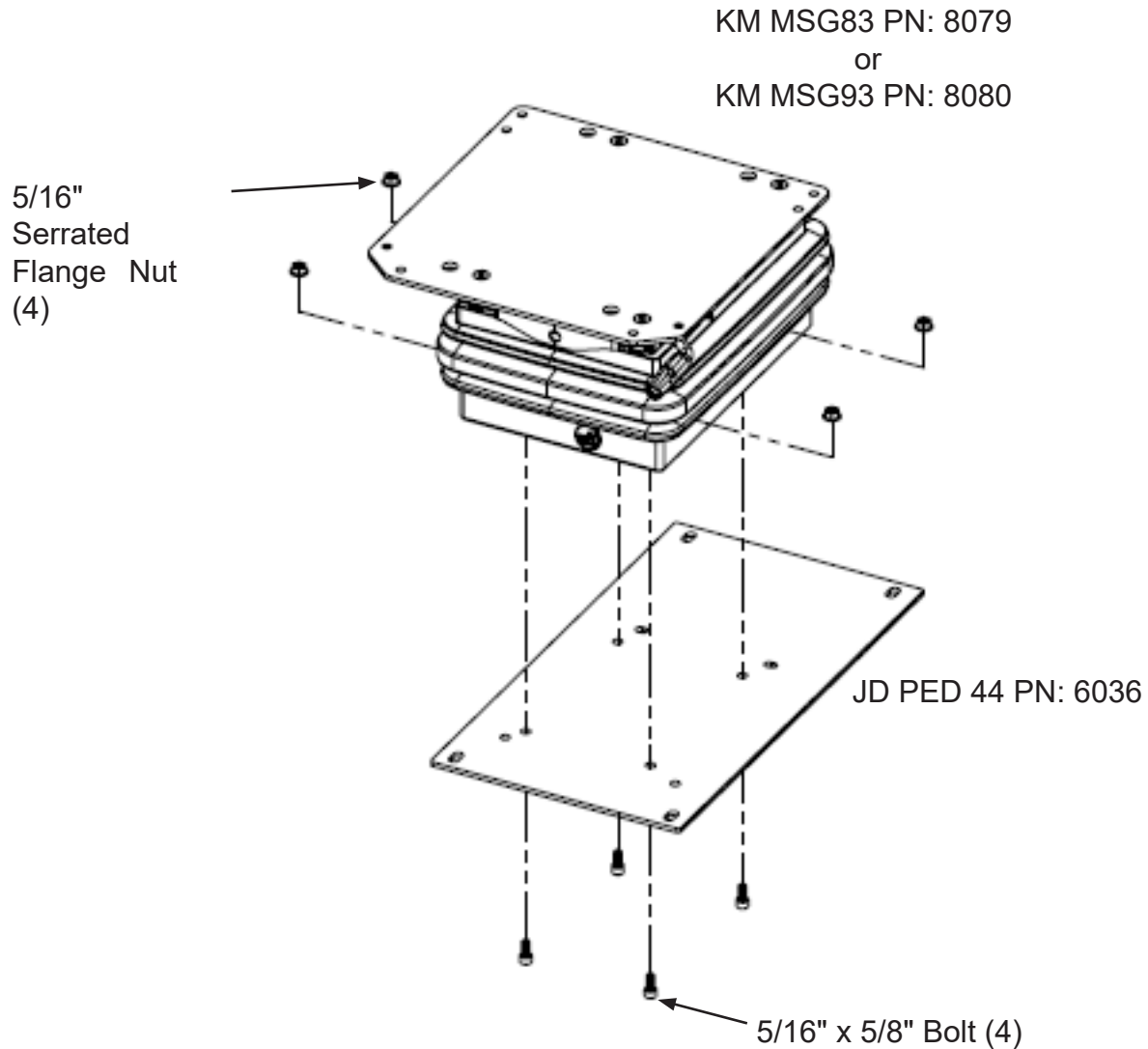

7. Mount the JD PED 44 and suspension assembly to the cab deck using the original bolts.

KM MSG83 PN: 8079
or
KM MSG93 PN: 8080

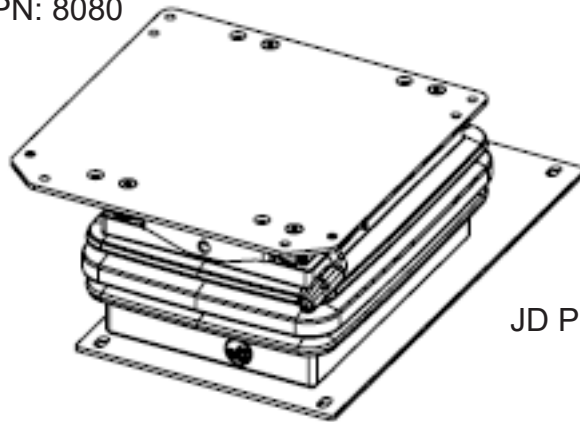

JD PED 44 PN: 6036

Installation Guide

KM 402 Kit Air/Mech Installation (PN: 6795 & 6796)

8. If a swivel was purchased, remove the plastic knock outs from the locations shown below. If no swivel was purchased, continue to step 15 on page 9.

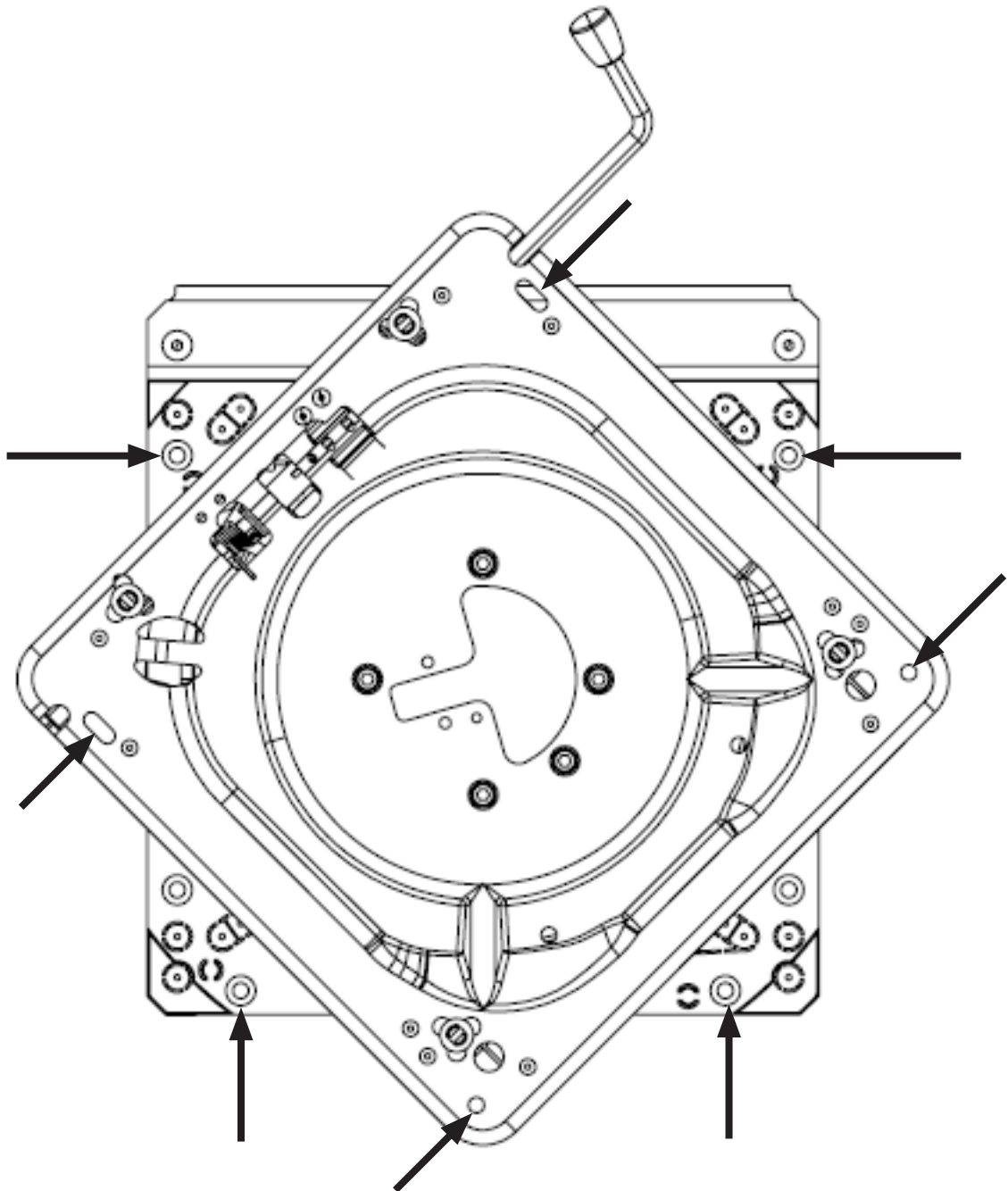

Installation Guide

KM 402 Kit Air/Mech Installation (PN: 6795 & 6796)

9. Rotate the swivel 45 degrees as shown below.
10. Mount the swivel to the 6080 SAP plate using four 5/16" x 5/8" socket head cap screws, lock washers, and 5/16" jam nuts.

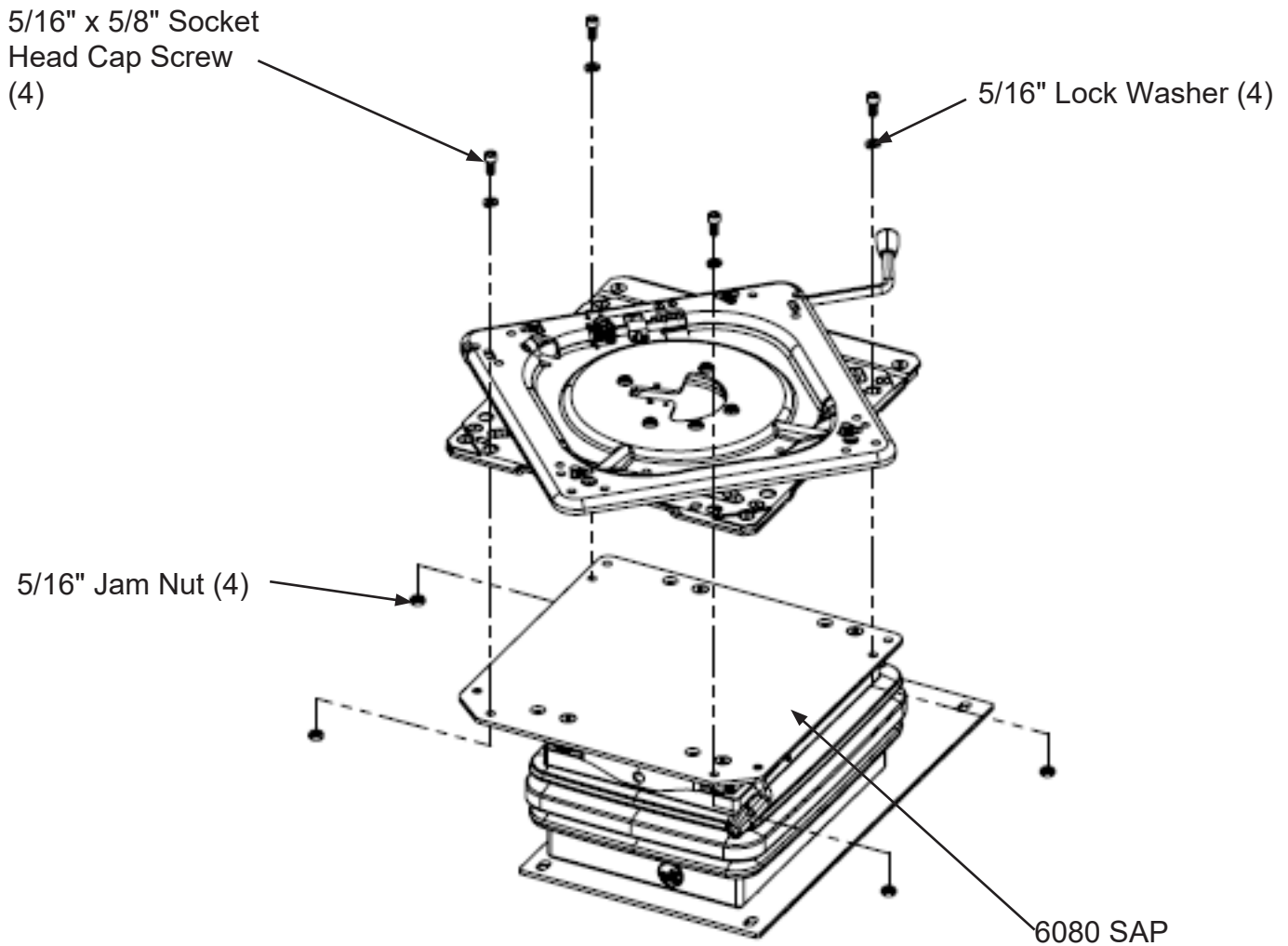

Installation Guide

KM 402 Kit Air/Mech Installation (PN: 6795 & 6796)

11. Remove the cushion from the new seat by taking out the three screws from the bottom front of the seat pan.
12. Mount the seat to the swivel using four 5/16" x 5/8" socket head cap screws and 5/16" serrated flange nuts.
13. Reinstall the seat cushion.
14. If the suspension is air, connect it to a power source. Keyed power is recommended.
Installation Complete.

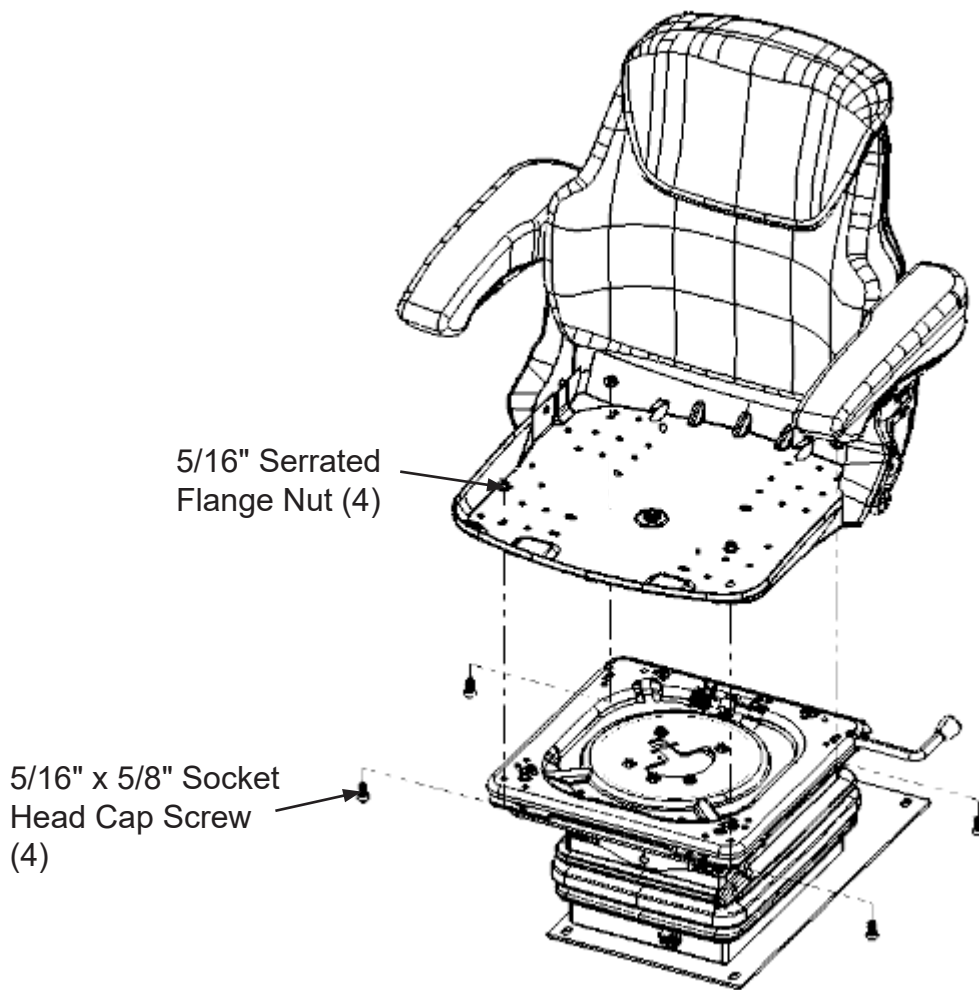

Installation Guide

KM 402 Kit Air/Mech Installation (PN: 6795 & 6796)

15. Remove the cushion from the new seat by taking out the three screws from the bottom front of the seat pan.
16. Mount the seat to the 6080 SAP using two 5/16" flat head socket cap screws and serrated flange nuts for the front holes and two 5/16" x 5/8" socket head cap screws and serrated flange nuts for the rear holes.
17. If the suspension is air, connect it to a power source. Keyed power is recommended.

