

Installation Guide

Installation Instructions for the Ultra Low Mechanical Suspension (PN: 6081)

1. When installing the ultra low mechanical suspension you will need to add clearance to the bottom of the suspension to allow the suspension to travel up and down. The easiest way to do this is to fasten your slide rails from your seat to the bottom of the suspension, then bolt the slide rails to your tractor/mower, and mount your seat to the top of the suspension. If you are unable to move your slide rails you will need to add $\frac{1}{2}$ "- $\frac{3}{4}$ " of space between your tractor/mower and the suspension. To do this, run the mounting bolts through a stack of washers or a pipe spacer $\frac{1}{2}$ "- $\frac{3}{4}$ " thick.



Installation Guide

Installation Instructions for a Seat with a Tube Frame Type Structure (PN: 6081)

1. Remove seat tracks from seat frame. Discard old hardware.
2. Bolt seat frame to the top of the suspension using the hardware illustrated in Detail C. *Tighten bolts to 101 inch-pounds of torque.*
3. Bolt tracks to the bottom of the suspension as illustrated in Detail C. *Tighten Bolts to 101 inch-pounds of torque.*

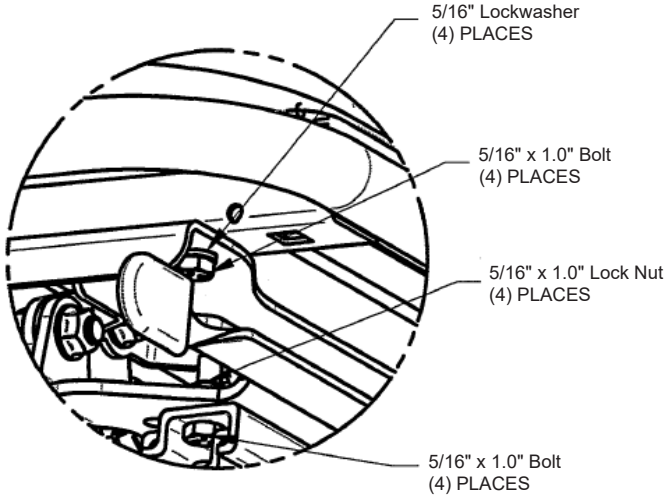

Detail C

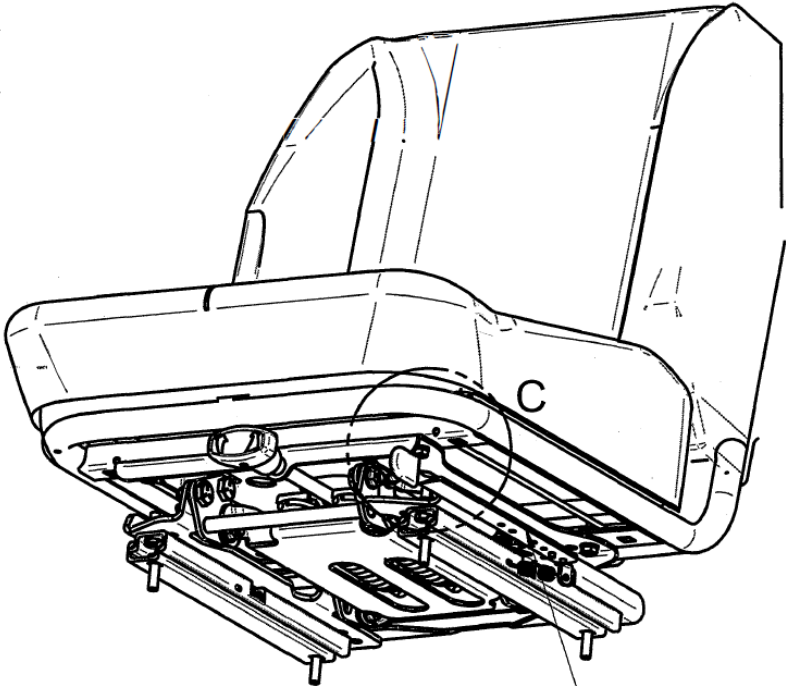

Install tracks so that the handle is to the outside.

Installation Guide

Installation Instructions to A Seat With A Shell Type Structure (PN: 6081)

IMPORTANT NOTE: Floor Mounting Needs To Be Flat.

1. Remove seat cushion by removing the (2) 1/4" screws on the bottom side.
2. Remove seats tracks. Discard old hardware.
3. Bolt seat shell to the top of the suspension using the hardware illustrated in *Detail A*. Tighten bolts to 101 inch-pounds of torque.
4. Bolt tracks to the bottom of the suspension as illustrated in *Detail B*. Tighten bolts to 101 inch-pounds of torque.
5. Reinstall seat cushion using the (2) 1/4" screws that were removed.

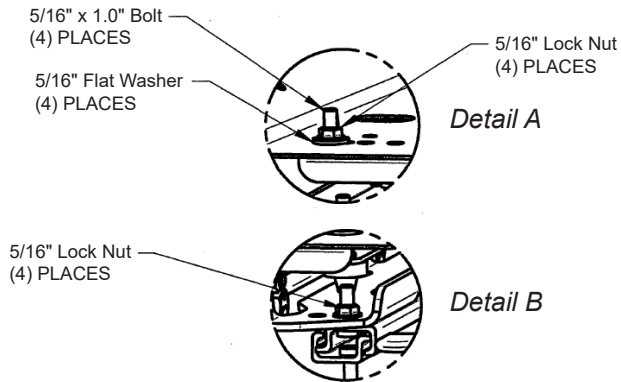

TO ENSURE PROPER SUSPENSION OPERATION:

1. Seat tracks must be removed from seat and re-attached under suspension as shown in *Detail B*.

-OR-

2. Seats Incorporated adapter bracket **must** be mounted under suspension.
3. Seat belts must **NOT** be attached to seat for any SAE J386 applications. Seat will **NOT** meet SAE J386

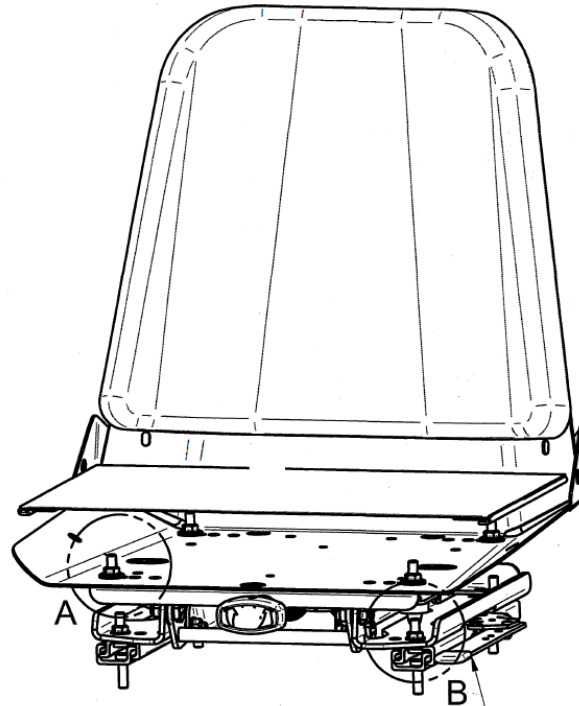

NOTE: Seat shown with the cushion removed for installation.

Install tracks so that the handle is to the outside.