



163cc Single-Direction Plate Compactor

Owner's Manual



! **WARNING:** Read and understand all instructions, warnings, and cautions before using this product. Failure to follow the instructions, warnings, and cautions may result in serious personal injury and/or property damage.

Item #49160

SAVE THESE INSTRUCTIONS

Thank you very much for choosing a Northstar™ product!

For future reference, please complete the owner's record below:

Serial Number/Lot Date Code: _____

Purchase Date: _____

Save the receipt, warranty, and this manual.

This plate compactor is designed for certain applications only. Northern Tool and Equipment cannot be responsible for issues arising from modification or use of this product in an application for which it was not designed. We strongly recommend that this product not be modified and/or used for any application other than that for which it was designed.

For technical questions, please call **1-800-222-5381**.

Table of Contents

Intended Use	4
Technical Specifications	4
Important Safety Information	5
Specific Operation Warnings	8
Main Parts of Plate Compactor	9
Before Each Use	10
Operating Instructions	11
Starting the Engine	11
Operation	11
Stopping the Engine	12
After Each Use	12
Maintenance	13
Changing the V-belt.....	14
Parts Diagram	15
Base Plate	15
Engine Base Plate	16
Frame and Handle	17
Vibratory Housing Assembly	18
Clutch and Belts.....	19
Troubleshooting	20
Replacement Parts	20
Limited Warranty	21

Intended Use

This compactor is designed to compact loose or granular soils and gravel. It is a powerful compacting tool capable of applying a tremendous force in consecutive high frequency vibrations to a soil surface. Its applications include compacting for road, embankments and reservoirs as well as backfilling for gas pipelines, water pipelines and cable installation work.

The compactor is intended to be used in confined areas and areas next to structures such as walls, curbs, and foundations. This plate is not recommended for compacting cohesive soils with a heavy clay content. For cohesive soil, use a vibratory rammer or sheeps-foot roller.

Power Source. The plate compactor is powered by a gasoline engine.

Supplies Required. Normal operation will require you to supply:

- Gasoline
- Engine oil
- Personal Protection Equipment

See “*Specifications*” section of this manual or Engine Manual for more detail.

*****Important: Intended for outdoor use only. Not to be used on pavement without a pad.*****

Technical Specifications

Compactor	
Weight	209.5 lbs. (95 kg)
Centrifugal Force	3979.3 lbf. (1805 kgf)
Vibration Frequency	100 Hz (6000 VPM)
Travel Speed	82 ft./min (25 m/min)
Grade Ability	20%
Compacted Area (depending on soil)	600 m ² /hr.
Power Take-Off	Centrifugal Clutch & V-Belt
Engine	
Engine Maker	HONDA
Engine Model	GX 160 / 163cc
Output Power(max)	5.5 Hp. (4.0 Kw)
Spark Plug	BPR6ES(NGK) W20EPR-U(DENSO)
Spark Plug Gap	0.028-0.031 in. (0.7-0.8 mm)
Engine Speed - Full Load	3,600±100 RPM
Engine Speed - Idle	1,400±100 RPM
Air Cleaner Type	Dual Element
Engine Oil Type	SAE 10W-30
Engine Oil Capacity	20 oz. (600 ml)
Fuel Type	Unleaded Gasoline
Fuel Tank Capacity	3.8 qt. (3.6 l)

Important Safety Information

⚠ WARNING

- The warnings, cautions, and instructions in this manual cannot cover all possible conditions or situations that could occur. Exercise common sense and caution when using this tool. Always be aware of the environment and ensure that the tool is used in a safe and responsible manner.
- DO NOT allow persons to assemble or operate this product until they have read this manual and have developed a thorough understanding of how the product works.
- Use the right tool for the job. DO NOT attempt to force small equipment to do the work of larger industrial equipment. There are certain applications for which this equipment was designed. It will do the job better and more safely at the capacity for which it was intended. DO NOT use this equipment for a purpose for which it was not intended.
- Industrial or commercial applications must follow OSHA requirements.

⚠ WARNING

- Some dust created by power sanding, sawing, grinding, drilling, and other construction activities contains chemicals known to the State of California to cause cancer, birth defects, or other reproductive harm. Some examples of these chemicals are:
 - lead from lead-based paints,
 - crystalline silica from bricks and cement and other masonry products, and
 - arsenic and chromium from chemically-treated lumber.

Your risk from these exposures varies, depending on how often you do this type of work. To reduce your exposure to these chemicals: work in a well-ventilated area, and work with approved safety equipment, such as dust masks that are specially designed to filter out microscopic particles.

⚠ WARNING

WORK AREA SAFETY

- Inspect the work area before each use. Keep the work area clean, dry, free of clutter, and well lit. Cluttered, wet, or dark work areas can result in injury.
- Do not use the tool where there is a risk of causing a fire or an explosion; e.g., in the presence of flammable liquids, gases, or dust. The tool can create sparks, which may ignite the flammable liquids, gases, or dust.
- Do not allow the tool to come into contact with an electrical source. The tool is not insulated and contact will cause electrical shock.
- Keep children and bystanders away from the work area while operating the tool. Do not allow children to handle the tool.
- Be aware of all power lines, electrical circuits, water pipes, and other mechanical hazards in your work area. Some of these hazards may be hidden from your view and may cause personal injury and/or property damage if contacted.

⚠ WARNING

PERSONAL SAFETY

- Stay alert, watch what you are doing, and use common sense when operating the tool. Do not use the tool while you are tired or under the influence of drugs, alcohol, or medication.
- Dress properly. Do not wear loose clothing, dangling objects, or jewelry. Keep your hair, clothing and gloves away from moving parts. Loose clothes, jewelry, or long hair can be caught in moving parts.
- Use ANSI Z87.1-approved safety goggles or safety glasses with side shields, or when needed, a face shield. Use a dust mask in dusty work conditions. Also use non-skid safety shoes, hardhat, gloves, dust collection systems, and hearing protection when appropriate. This applies to all persons in the work area.
- Do not overreach. Keep proper footing and balance at all times.
- Remove keys or wrenches before connecting the tool to the power supply or turning on the tool. A wrench or key that is left attached to a rotating part of the tool may cause personal injury.
- No smoking, matches, or open flames around the compactor. Fuel is flammable.
- Do not touch hot surfaces.
- Equipment can tip over when moving, causing injury.
- Persons not operating should be at least 10 feet away while equipment is in use.
- Engine exhaust contains carbon monoxide. This is a poison you cannot see or smell. NEVER use in doors.
- Do not operate without guards in place.

⚠ CAUTION

COMPACTOR USE AND CARE

- Do not force the product. Products do a better and safer job when used in the manner for which they are designed. Plan your work, and use the correct product for the job.
- Check for damaged parts before each use. Carefully check that the product will operate properly and perform its intended function. Replace damaged or worn parts immediately. Never operate the product with a damaged part.
- Put the power switch in the locked or off position before making any adjustments, changing accessories, or storing the tool. Such preventive safety measures reduce the risk of starting the tool accidentally.
- Store the product when it is not in use. Store it in a dry, secure place out of the reach of children. Inspect the product for good working condition prior to storage and before re-use.
- Use only accessories that are recommended by the manufacturer for use with your product. Accessories that may be suitable for one product may create a risk of injury when used with another product.
- Keep guards in place and in working order. Never operate the product without the guards in place.
- Do not leave the product running unattended.
- Shut off the fuel valve when the engine is not in use.
- Only use the recommended fuel to avoid damaging the equipment.
- Oil does not come with the machine. Add oil to engine before the first use.
- Check oil levels before operating the machine.
- DO NOT refuel the engine while it is still hot. Fuel is flammable.
- DO NOT service engine while it is still hot.

Specific Operation Warnings

⚠ WARNING

To avoid fatal accident

- Stop the engine before refueling and be careful not to spill fuel. Spilled fuel may ignite.
- Do not refuel the engine near flammable objects to avoid fire.
- Do not run the engine in enclosed areas to prevent carbon monoxide poisoning.

To protect the operator

- When fatigued from operation, stop the machine and take break.
- Hearing protection is required as this machine creates a noise emission while 1 m (3 feet) away from the equipment.

To avoid injury or damage

- The compactors are only operated by authorized persons who:
 - are at least 18 years of age.
 - are physically and mentally able to operate the plate compactor.
 - are properly trained in the operation and the maintenance of the plate compactor by the owner or its authorized representative.
 - are assessed to be able to carry out their duties reliably.
- Do not operate the compactor when any condition endangers the safety of the operator. Correct the condition before operating the compactor.
- Do not operate the compactor while under the influence of medication or alcohol.
- The operator must monitor the immediate area all the times. Do not operate the compactor if a person is in the immediate area because cracked and bounced rock may cause injury. Also monitor other objects within 20m in case of lighting.
- The compactor can only be operated under adequately stable conditions.
- The operator must turn off the compactor completely as described in this manual before leaving the operating position. Also, the compactor must be secured against unauthorized use.
- The engine must be turned off and secured against re-starting by pulling out the spark plug before maintenance and servicing.
- The compactor has to be inspected by an authorized service technician on a regular basis (at least once a year). The compactor generates mechanical heat so do not touch the engine, muffler or other parts during the operation, which may cause a burn. Please wait until the compactor cools down before inspecting components.
- The operator must be fully equipped with safety equipment including a helmet, safety gloves, safety shoes, safety glasses, a mask, and hearing protection before operating the compactor.
- Do not insert a hand or finger between the pulley cover and engine during operation as it will break the hand or finger.
- Sprinkle the water on the working area to avoid dust before operating but NEVER operate the compactor if the working area is too wet because it may damage the life cycle of the product.
- Lift the plate compactor by the curved center of the frame using a proper lifting crane when moving it on and off a truck. Lifting the compactor by hand may cause personal injury due to its heavy weight.
- Securely fasten the compactor for transportation. Insecure fastening of the compactor may cause damage or injury during transportation.
- Do not transport the compactor by motor vehicle with fuel in its fuel tank.

Note: Refer to the instruction manual of the engine if there is a problem or a question about it before or during its operation.

Main Parts of Plate Compactor

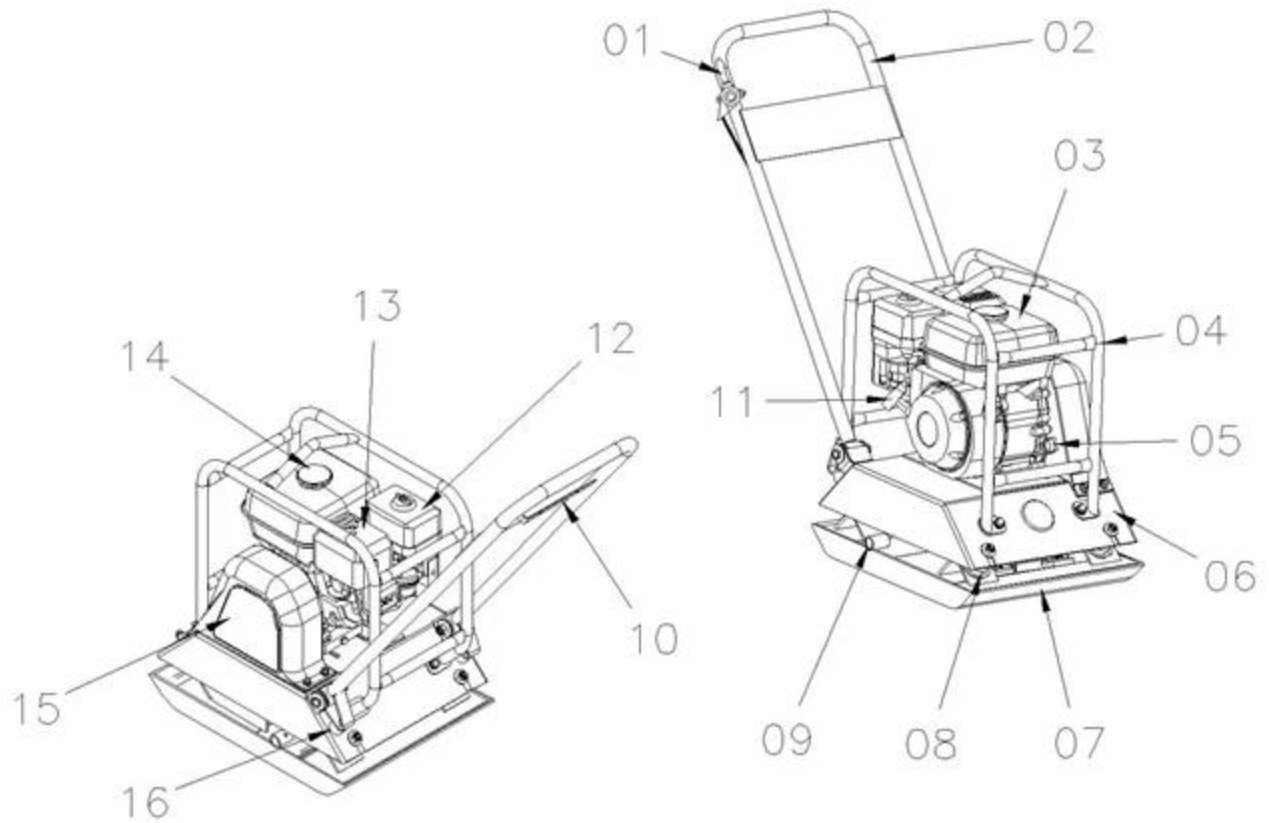

01	Accelerator lever
02	Handle
03	Engine Fuel Tank
04	Frame
05	Engine Oil Gauge
06	Engine Base Plate
07	Vibratory Plate
08	Isolated Rubber
09	Transfer Wheel Bushing
10	Tool Pocket
11	Engine Recoil Starter
12	Engine Air Filter
13	Engine Muffler
14	Engine Fuel tank Cap
15	Belt Cover
16	Handle Stopper Rubber

Before Each Use

Engine

Recommended Fuel

- The compactor engine requires fresh, clean, regular, unleaded gasoline. Fuel containing water or dirt will damage the fuel system. Consult to engine owner's manual for complete fuel specifications

▲ WARNING

DANGER: Adding fuel to the tank should be done only when the engine is stopped and has had an opportunity to cool down to avoid a risk of an explosion or fire from a fuel spill. In the event of a fuel spill, **DO NOT** attempt to start the engine until the fuel residue has been completely wiped up, and the area surrounding the engine is dry.

Before starting

- Read and understand the safety and operating instruction manual of the engine.
- Check:
 - Oil level in engine.
 - Fuel level.
 - Condition of air cleaner.
 - Tightness of external fasteners.
 - Condition of fuel lines.

Compactor

- Check all the bolts, nuts and belts and tighten any if necessary.
- Check the general condition of the compactor and its components and clean any foreign material (dirt, fragments, etc.) from the compactor that may be thrown off and cause injury.

Operating Instructions

⚠ WARNING

Read and understand both the engine and compactor user's manuals before starting or operating the compactor to avoid incorrect operation that may result in damage or injury.

Starting the Engine

1. Perform all the Before Each Use steps.
2. Shift the engine On/Off switch to "ON".
3. Open the fuel valve.
4. If the engine is cold, move the choke lever to the "close" position. If the engine is hot, set the choke lever to the "open" position.
5. Turn the accelerator lever fully counterclockwise.
6. Pull the starter grip gently until resistance is felt, then pull hard.
7. Leave the engine run idle for 5 minutes for warm-up.
8. Turn the accelerator lever fully clockwise to open the throttle fully and operate plate compactor.

Operation

⚠ WARNING

Read and understand both the engine and compactor user's manuals before starting or operating the compactor to avoid incorrect operation that may result in damage or injury.

Note: Whenever high speed operation (over than 3600 RPM) is NOT required, slow the engine by moving the speed control lever to a low position to save fuel and extend the life of the equipment.

1. Once the engine has started and warmed up, firmly grasp the compactor's handle bar with one hand then quickly turn the throttle lever to high speed. The engine speed should be around 2,300 RPM and therefore engage the centrifugal clutch.
Note: Always move the throttle lever quickly without hesitation, because increasing the engine speed slowly will cause the clutch to slip.
2. Firmly grasp the compactor's handle bar with both hands as the compactor begins to move forward.
3. Walk behind the compactor watching for any large objects or foreign matter that might cause damage to the compactor or shoot out causing bodily injury. If objects are in the travel path, slow the engine (stopping compactor travel) and remove the object before proceeding.

The compactor's travel speed may slow down on soils that contain clay, however there may be cases where the travel speed slows because the vibrator/compaction plate does not leave the ground surface easily due to the composition of the soil. To correct this problem:

- (With the compactor turned off) check the vibrator plate to see if clay or other material has been lodged in the mechanism. If so, clean the plate/mechanism with water and remove the material.
- Remember that the compactor does not work efficiently on clay or very moist soil.
- If the soil is very moist, dry it to a suitable level or perform compaction twice.

Stopping the Engine

⚠ CAUTION

Never stop the engine abruptly from full speed. Slow the speed and allow the engine to run idle for a few minutes. This is necessary to prevent the moisture of the outside air from getting into the engine carburetor.

- Slow the engine to idle by turning accelerator lever fully counterclockwise.
- Shift the engine On/Off switch to the “OFF” position.
- Close the fuel valve.

See the engine manual for further information.

After Each Use

- Remove the foreign substances such as soil, stone or dirt from compactor and engine.
- Clean the engine cylinder cooling fins.
- Clean or replace the air filter.
- Check the general condition of the compactor.

Storage

In case of storing the plate compactor for a long period of time (for more than 30 days):

- Drain the fuel tank completely.
- Run the engine until the fuel in the fuel in the carburetor is completely consumed.
- Drain the engine oil and follow procedures described in engine manual for engine storage.
- Cover the compactor completely with dry cloth for storage.
- Store the compactor in a clean, dry place.

Maintenance

⚠ WARNING

Check that the compactor engine is turned off and cooled before attempting any maintenance, cleaning, or inspection. Performing maintenance on an operating compactor can cause injury.

Maintain the compactor by adopting a program of conscientious repair and maintenance in accordance with the following recommended procedures. Also refer to the engine manufacturer's instruction manual for additional information about engine maintenance. The following chart is based on a normal operation schedule.

Maintenance Interval	Maintenance Point
Daily before operating	Check the fuel level. Check the engine oil level. Inspect the fuel lines. Inspect the air filter and replace it if needed. Check and tighten the external hardware.
After the first 20 operating hours	Check and adjust the drive belt. Change the engine oil.
After the first 50 operating hours or every week	Check and adjust the drive belt. Clean the air cleaner element. Change the engine oil. Check and clean the spark plug.
After the first 100 operating hours or every month	Clean the fuel strainer.
After the first 300 operating hours or every year	Check and adjust the valve clearance. Clean the cylinder head. Change the lubrication oil (SHELL OMALA #100 OR SAE 10W/30, 150CC)

Changing the V-belt

⚠ WARNING

Check that the compactor engine is turned off and cool before attempting to change the V-belt. Changing the V-belt while the compactor is still operating may cause injury.

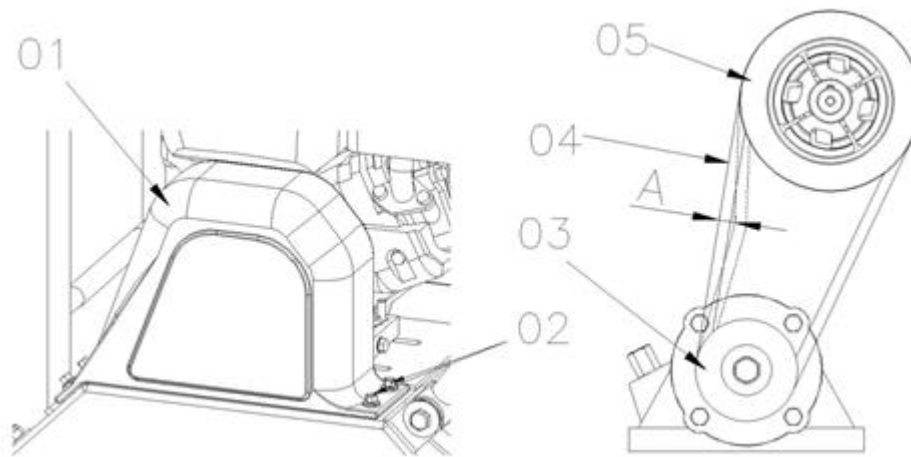

1. Loosen the four flange bolts (02, both sides of the cover) to remove the belt cover (01).
2. Remove both belts.
3. Prepare new belts (item 3 in the Clutch and Belt parts list).
4. When fitting each belt, fit to the smaller pulley (03) first, and then fit the bigger pulley (05).
5. With the belts installed, check whether the distance of A is $\frac{3}{8}$ ' by pushing in on each belt.
6. Reinstall the belt cover with the flange bolts and tighten the bolts.

Parts Diagram

Base Plate

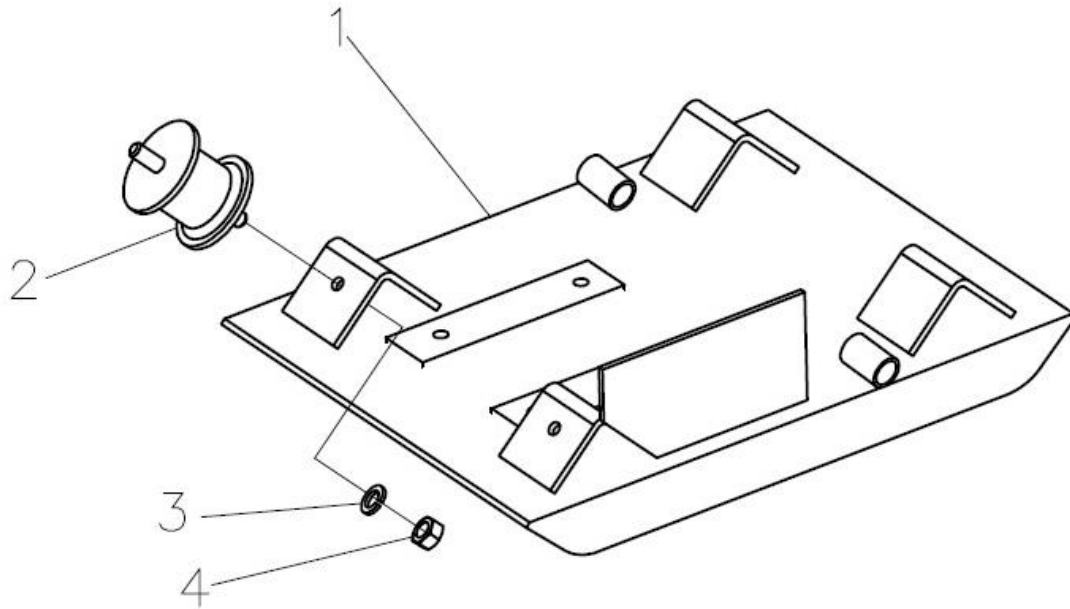

Ref.	Part No.	Description	Qty.	Remark
1	PB010-000	80 Base Plate WA	1	545*415
2	PB130-001	Vibration Isolator Rubber(60)	4	NBR
3	QWS-SM10	Spring Washer	4	M10
4	QNT-M10	Nut	4	M10

Engine Base Plate

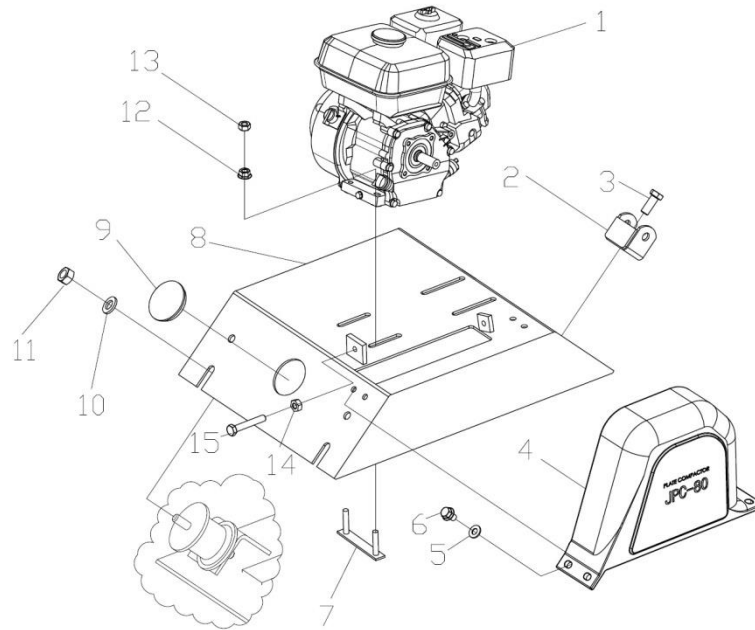

Ref.	Part No.	Description	Qty.	Remark
1	GX160-S	Engine	1	GX-160 S-type
2	PB050-000B	Handle Bracket WA	2	
3	QBL-M10X25	Bolt	2	M10*25L
4	PB130-001	Belt Cover	1	
5	QWS-PM8	Plain Washer	4	M8
6	QBL-FM8x25	Flange Bolt	4	M8*25
7	Fix45-000	Engine Fixing Bolt	2	
8	PB020-000B	80 Engine Base WA	1	
9	PB130-004	Rubber Cap	1	
10	QWS-SPM10H	Plane Washer	4	M10 Ø30 (10.9T)
11	QNT-NM10	Nylon Nut	4	M10
12	QNT-FM8	Flange Nut	4	M8
13	QNT-M8	Nut	4	M8
14	QNT-M10	Nut	1	M10
15	QBL-M10X50	Bolt	1	M10*50L

Frame and Handle

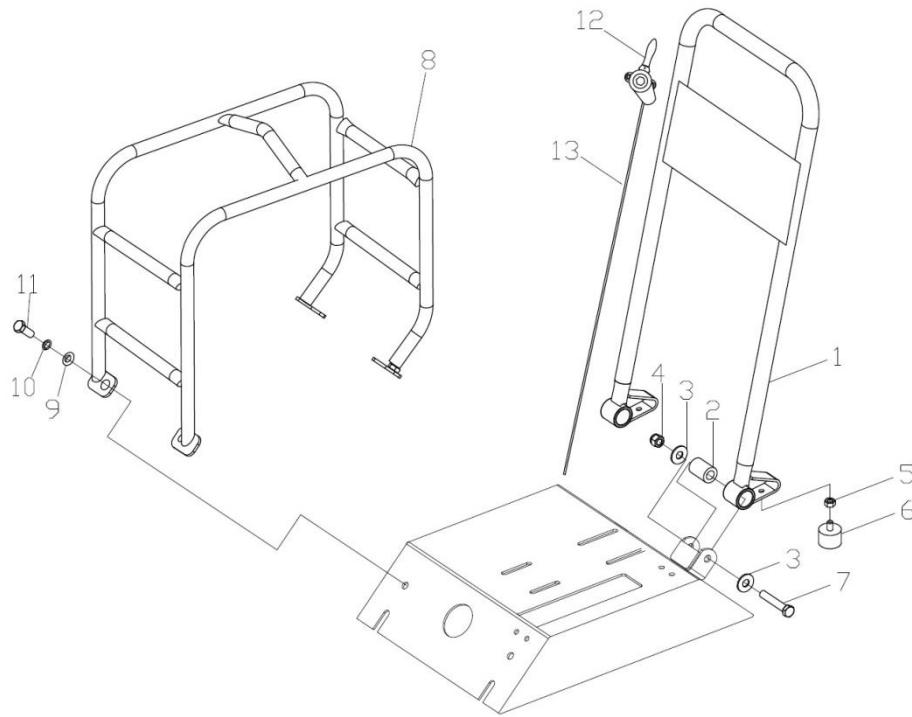

Ref.	Part No.	Description	Qty.	Remark
1	PB070-000	80 Handle WA	1	
2	PB130-003	Handle Bushing Rubber	2	
3	QWS-PM12	Plain Washer	4	M12
4	QNT-NM12	Nylon Nut	2	M12
5	QNT-M8	Nut	2	M8
6	PB130-002	Handle Stop Rubber	2	
7	QBL-M12X70S	Bolt	2	M12*70L(10.9)
8	PB030-000	Frame Welding Assembly	1	
9	QWS-PM10	Plain Washer	4	M10
10	QWS-SM10	Spring Washer	4	M10
11	QBL-M10X25	Bolt	4	M10*25L
12	QTL-02	Throttle Lever	1	
13	QTC-900	Throttle Cable	1	

Vibratory Housing Assembly

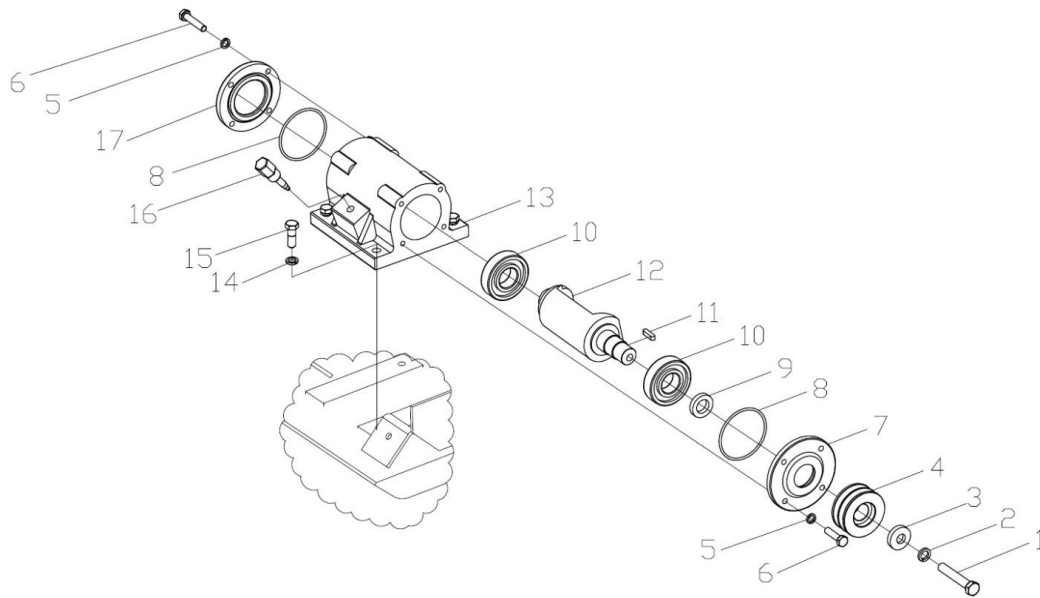

Ref.	Part No.	Description	Qty.	Remark
1	QBL-M12X35	Bolt	1	M12x35
2	QWS-SM12	Spring Washer	1	M12
3	QWS-SPM12	Plane Washer	1	M12 Ø40
4	PB040-006	Vibrator Pulley	1	GCD200
5	QWS-SM8H	Spring Washer	8	M8 (10.9T)
6	QBL-M8X25H	Bolt	8	M8X25 (10.9T)
7	PB040-004	Vibrator Front Cover	1	GCD200
8	QOR-G80	O-ring	2	G80
9	QOS-32X48X8	Oil Seal	1	32 x 48 x 8 NOK
10	QBR-6307	Bearing	2	#6307
11	QKY-7X7X20	Key	1	7X7X20
12	PB040-001	Vibrator Rotary Shaft	1	GCD450
13	PB040-002	Vibrator Housing	1	GCD450
14	QWS-SM12S	Spring Washer	4	M12 (10.9T)
15	QBL-M12X45S	Bolt	4	M12x45 (10.9T)
16	PP200-005	Vibrator Oil Gage	1	SM20C
17	PB040-003	Vibrator Rear Cover	1	GCD200

Clutch and Belts

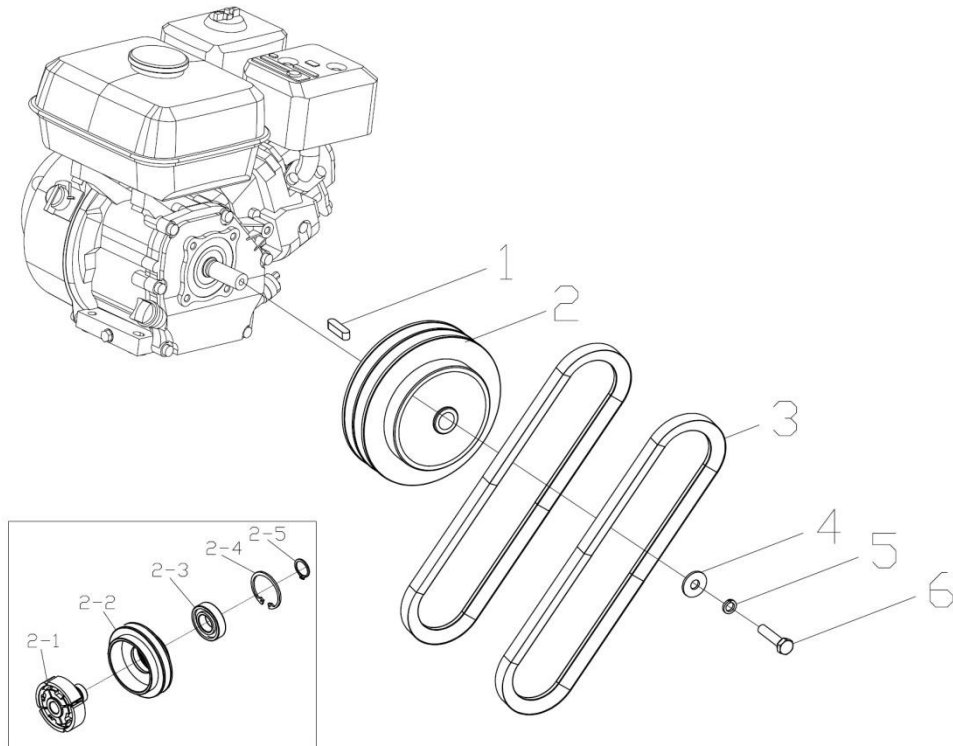

Ref.	Part No.	Description	Qty.	Remark
1	QKY-5X5X50	Key	1	5X5X50
2	PB100-20	Clutch Pulley Assembly	1	
3	QBT-A29	V-Belt	2	A29
4	QWS-SPM8H	Plane Washer	1	M8 Ø35 (10.9T)
5	QWS-SM8	Spring Washer	1	M8
6	QBL-M8X40	Bolt	1	M8X40
2-1	Clutch-20	Clutch Shoe(Φ20)	1	FC20
2-2	PB100-001	Clutch Pulley	1	GCD200
2-3	QBR-6206	Bearing	1	6206zz
2-4	QSR-R62	Snap Ring	1	R62
2-5	QSR-S30	Snap Ring	1	S30

Troubleshooting

Please check the list below before addressing the problems to servicing personnel including local dealer. If the problem continues after the following troubleshooting, please call your local dealer for future assistance.

Failure	Possible Cause	Solution
Poor performance (compactor does not develop its full speed)	The engine throttle does not open completely.	Open the engine throttle completely.
	The throttle does not adjusted correctly.	Adjust the throttle controller correctly.
	The ground is too wet for compacting.	Dry the soil before compacting.
	Drive belt is loosened or worn out, slipping on pulleys.	Adjust/replace the belt. Or check whether the engine mounting bolts are tightened.
	Vibrating shaft bearings (#19) is binding.	Check the condition & the level of the oil in vibrator housing, and add/change the oil.
	Air filter is clogged with dust which reduces engine performance.	Clean/replace the air filter cartridge.
	The engine speed is too low.	Check the engine speed with tachometer and adjust/repair the engine to run at correct speed. Note: Refer to the engine manual.
Engine is running but no vibration	The engine throttle is not opened.	The drive belt is loosened or broken. Adjust/ replace it.
	Clutch is damaged.	Inspect/replace the clutch.
	Engine speed is too low.	Turn Accelerator lever fully clockwise
	V-belt is worn	Adjust/replace the V-belt
Plate jumps or compacts unevenly	The ground surface is too hard.	
	Rubber isolator is loosened or damaged.	Adjust/replace the rubber isolator.

Replacement Parts

- For replacement parts and technical questions, please call Customer Service at **1-800-222-5381**.
- Not all product components are available for replacement. The illustrations provided are a convenient reference to the location and position of parts in the assembly sequence.
- When ordering parts, the following will be required: Model Number, Serial Number/Lot Date Code, and Description.
- The distributor reserves the rights to make design changes and/or improvements to product lines and manuals without notice.

Limited Warranty

Northern Tool and Equipment Company, Inc. ("We" or "Us") warrants to the original purchaser only ("You" or "Your") that the North Star product purchased will be free from material defects in both materials and workmanship, normal wear and tear excepted, for a period of **two years** from date of purchase with the Honda GX engine having a period of three years from date of purchase. The foregoing warranty is valid only if the installation and use of the product is strictly in accordance with product instructions. There are no other warranties, express or implied, including the warranty of merchantability or fitness for a particular purpose. If the product does not comply with this limited warranty, Your sole and exclusive remedy is that We will, at our sole option and within a commercially reasonable time, either replace the product or product component without charge to You or refund the purchase price (less shipping). This limited warranty is not transferable.

Limitations on the Warranty

This limited warranty does not cover: (a) normal wear and tear; (b) damage through abuse, neglect, misuse, or as a result of any accident or in any other manner; (c) damage from misapplication, overloading, or improper installation; (d) improper maintenance and repair; and (e) product alteration in any manner by anyone other than Us, with the sole exception of alterations made pursuant to product instructions and in a workmanlike manner.

Obligations of Purchaser

You must retain Your product purchase receipt to verify date of purchase and that You are the original purchaser. To make a warranty claim, contact Us at 1-800-222-5381, identify the product by make and model number, and follow the claim instructions that will be provided. The product and the purchase receipt must be provided to Us in order to process Your warranty claim. Any returned product that is replaced or refunded by Us becomes our property. You will be responsible for return shipping costs or costs related to Your return visit to a retail store.

Remedy Limits

Product replacement or a refund of the purchase price is Your sole remedy under this limited warranty or any other warranty related to the product. We shall not be liable for: service or labor charges or damage to Your property incurred in removing or replacing the product; any damages, including, without limitation, damages to tangible personal property or personal injury, related to Your improper use, installation, or maintenance of the product or product component; or any indirect, incidental or consequential damages of any kind for any reason.

Assumption of Risk

You acknowledge and agree that any use of the product for any purpose other than the specified use(s) stated in the product instructions is at Your own risk.

Governing Law

This limited warranty gives You specific legal rights, and You also may have other rights which vary from state to state. Some states do not allow limitations or exclusions on implied warranties or incidental or consequential damages, so the above limitations may not apply to You. This limited warranty is governed by the laws of the State of Minnesota, without regard to rules pertaining to conflicts of law. The state courts located in Dakota County, Minnesota shall have exclusive jurisdiction for any disputes relating to this warranty.



Distributed by
Northern Tool and Equipment Company, Inc.
Burnsville, Minnesota 55306
NorthernTool.com

Made in Korea