

Installation Guide

JD 7R-8R/RT-9R/RT/RX Series Footrest Kit (PN: 3454)

1. Disconnect the negative cable from the battery.
2. Remove the floor mat from the cab of the tractor.
3. Remove bolts marked A and loosen bolts marked B in the images below to take out the floor plate below the pedals. Keep the hardware as it will be reinstalled later.

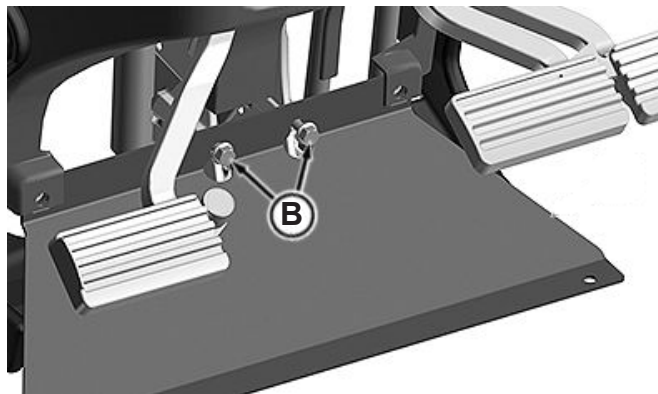
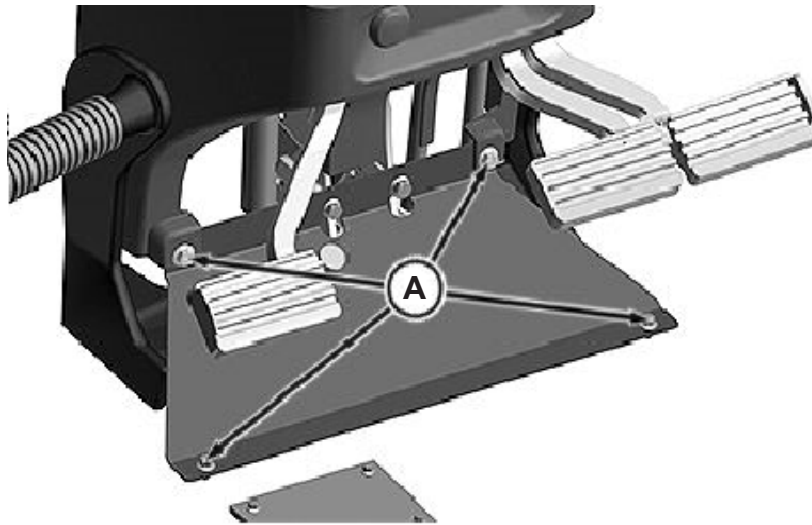

Installation Guide

JD 7R-8R/RT-9R/RT/RX Series Footrest Kit (PN: 3454)

4. Remove the three bolts on the left side of the steering column support marked A in the image below. These bolts can be discarded.
5. Install the 12611 LH Foot Rest on top of the steering column support where the bolts in step 4 were removed.
6. Use one 8mm x 50mm flange bolt, two 12mm x 50mm flange bolts, and 12mm flat washers as shown below.
NOTE: There is a geometry difference between the IT4 and FT4 models. The front two washer are only used in certain cases. To determine if the washers are needed, set the 12611 LH Foot Rest in place and see if there is a gap between the Foot Rest and the steering column support.
7. Tighten hardware.

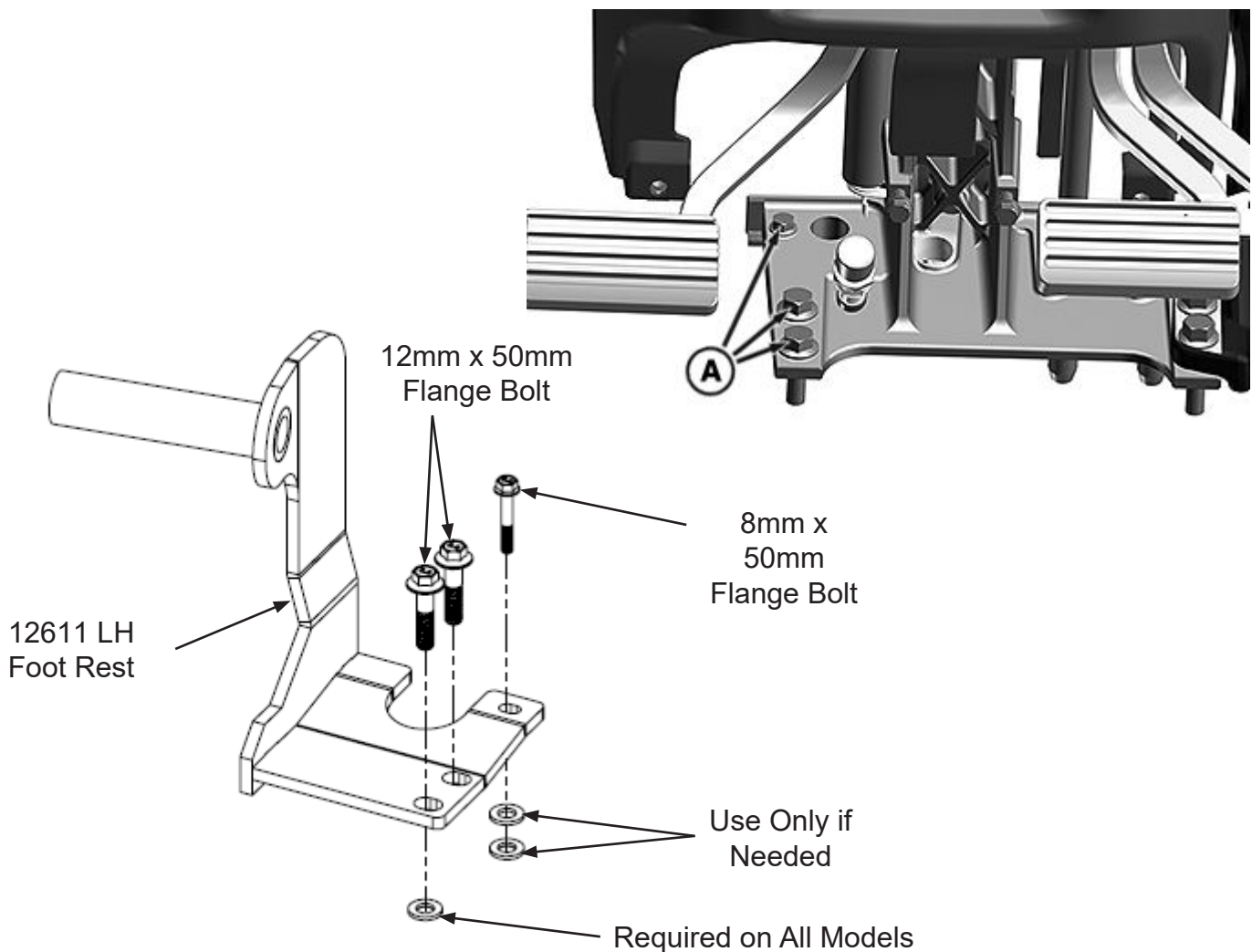

Installation Guide

JD 7R-8R/RT-9R/RT/RX Series Footrest Kit (PN: 3454)

8. Remove the three bolts on the right side of the steering column support marked A in the image below. These bolts can be discarded.
9. Install the 12615 RH Foot Rest on top of the steering column support where the bolts in step 8 were removed.
10. Use one 8mm x 50mm flange bolt, two 12mm x 50mm flange bolts, and 12mm flat washers as shown below. Refer to **NOTE** below.
11. Tighten hardware.

NOTE: There is a geometry difference between the IT4 and FT4 models. The three flat washer are only used in certain cases. To determine if the washers are need-ed, set the 12615 RH Foot Rest in place and see if there is a gap between the Foot Rest and the steering column support.

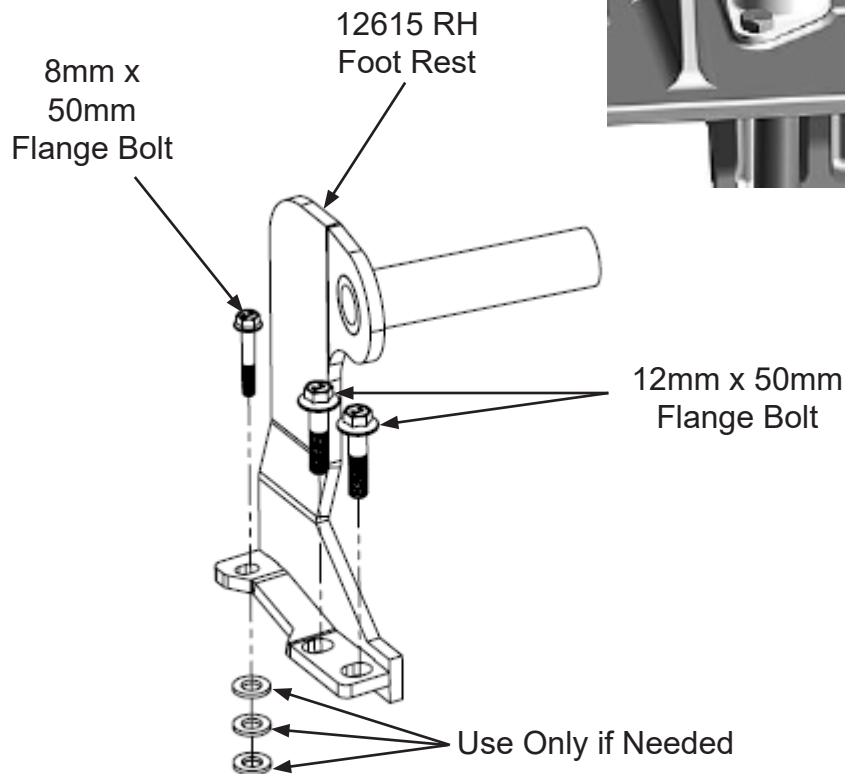
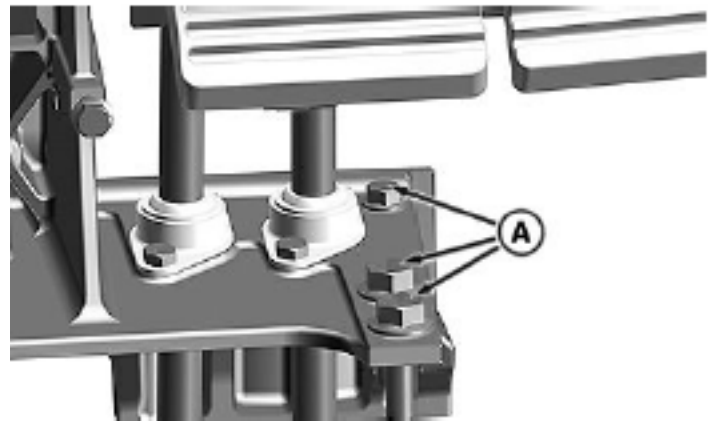

12. Apply the provided anti-slip tape strips to the pegs on each footrest.
13. Reinstall the floor plate below the pedals using the original hardware.
14. Reinstall the floor mat.
15. Reconnect the negative battery cable.