

Installation Guide

John Deere 8000D Series Window Step (PN: 3418)

1. Fasten the front bolt-on steps in the desired position on the front step weldment using five 5/16" x 3/4" bolts and flange nuts. Do not use the hole closest to the tractor at this time. For tractors with front dual wheels, install only one front bolt-on step in the center mounting location.
2. For IVT tractors, attach the IVT bracket using the holes labeled "Hole Set 2". For Power Shift tractors, use the holes labeled "Hole Set 1". Fasten with a 5/16" x 3/4" bolt and flange nut in the top hole and a 5/16" x 1" bolt and flange nut in the bottom hole.
3. Bolt the end of the IVT bracket to the tractor using two 20mm x 45mm bolts and two 3/4" flat washers.
4. Fasten the side step section to the front step weldment using two 5/16" x 1" bolts and flange nuts.

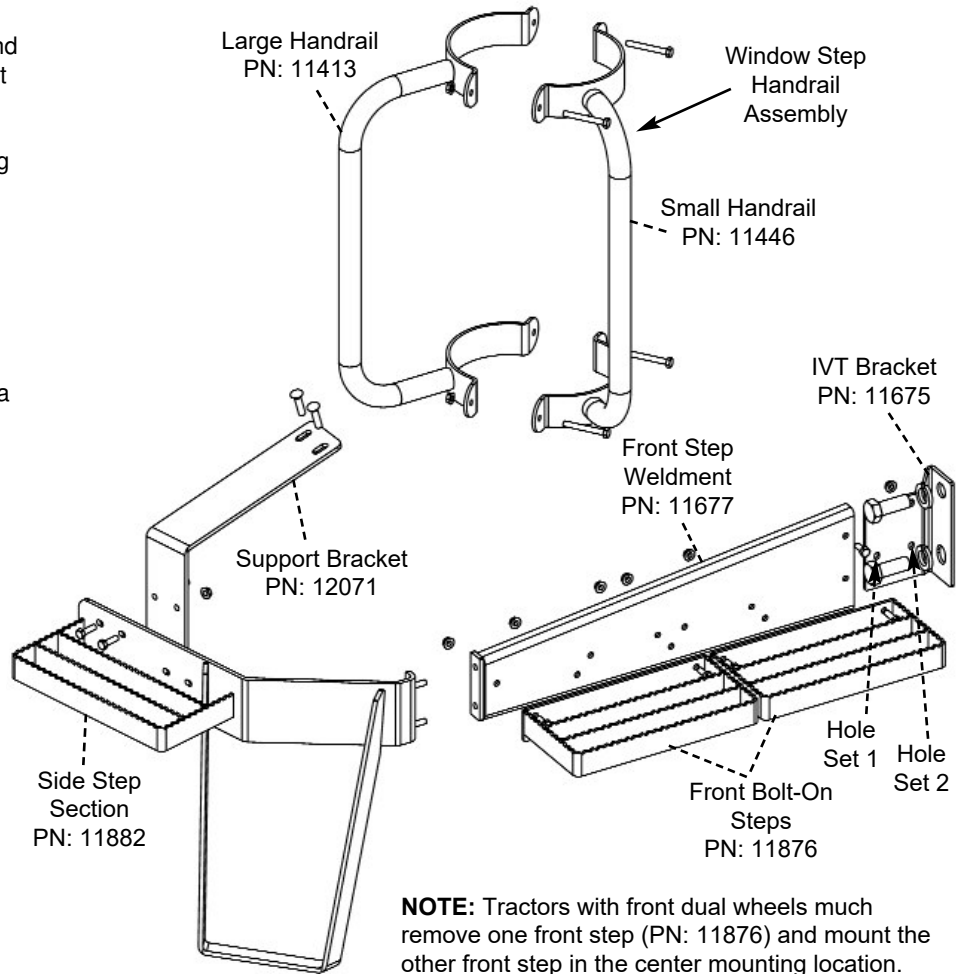

5. Fasten the lower end of the support bracket to the side step sections using two side step section using two 5/16" x 1" bolts and flange nuts.
6. Fasten the upper end of the support bracket to the fuel tank strap using two 10mm x 20mm bolts.
7. Locate the handrail the desired height on the muffler shield.
8. Fasten the handrails together using four 5/16" x 2 1/2" bolts and flange nuts.
9. After step installation, check turning radius of front tires for interference with step.

NOTE: Do not tighten any bolts until all parts have been assembled to the tractor.