

# Installation Guide

## Case 94 Series Step & Handrail (Excludes Tube Step) (Step PN: 3337 / Handrail PN: 3336)

1. Remove the original step from the tractor cab.
2. Bolt the step **mounting bracket** to the cab using the four original step bolts.
3. Place the pivot arm of the **top step section** against the bottom of the **mounting bracket** and fasten with a 1/2" x 3 1/2" capscrew, lock washer and nut; and one 3/8" x 1 1/2" carriage bolt, flat washer, lock washer and nut.
4. Rotate the step to the desired position and tighten all bolts securely.
5. Slide the **bottom step section** along the outside of the **top step section** to the approximate height and clamp it at that position.
6. The two **intermediate steps** should be positioned so that all steps are evenly spaced.
7. Fasten the **upper intermediate step** with four 3/8" x 1" carriage bolts, flat washers, lock washers and nuts.
8. Fasten the **lower intermediate step** with four 3/8" x 3/4" carriage bolts, flat washers, lock washers and nuts.
9. Fasten the upper end of the **handrail** to the upper end of the side plate on the **top step section** with a 3/8" x 1" capscrew, lock washer and nut.
10. Fasten the lower end of the **handrail** to one of the slotted holes about midway down the side. Secure with a 3/8" x 1 1/2" capscrew, lock washer and nut.

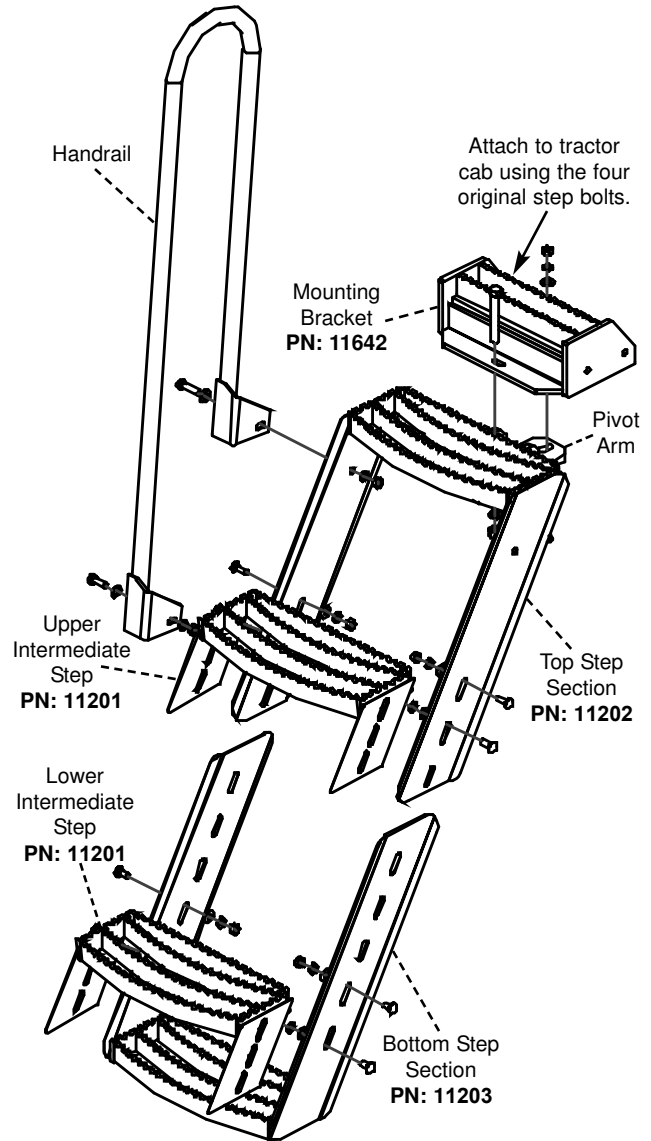

**NOTE:** It may require some adjusting of the parts to make the hole for the lower end of the handrail appear.