

1. Locate the four holes on the underside of the left side fender. Remove the plastic caps and push through with a Phillips screwdriver to mark the holes on the inside of the cap perpendicular to the fender.
2. Use a spacer as a guide to cut the foam around the holes marked in Step 1.
3. Place the four spacers into the holes made in step 2. Use the 3" spacers toward the inside of the cab and the 2" spacers toward the outside of the cab.
4. Insert the two 3/8" x 3" carriage bolts and the two 3/8" x 4" carriage bolts into the holes in the 11000 mounting plate marked on the drawing below.
5. Bolt the seat to the 11000 mounting plate with four 3/8" x 3/4" carriage bolts and flange nuts. Note: There are two different height setting available for the seat.
6. Insert the seat mounting bolts into the spacers and through the cab fender. Fasten with flat washer and flange nut on the bottom side of the fender. Insert the seat mounting bolts into the spacers and through the cab fender. Fasten with flat washer and lock nut on the bottom side of the fender.
7. Unfold the seat and check to make sure the seat sits level. If it tips back, remove the seat and mounting plate and proceed to step XX to install the angle brackets. If the seat is level proceed to step XX to finish the assembly.

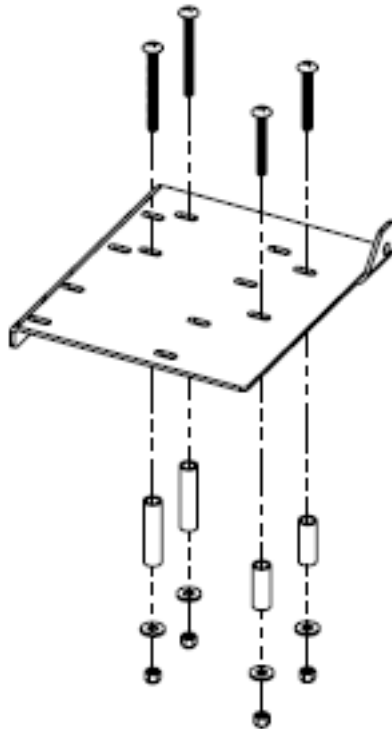

8. Remove the seat and mount plate assembly from the cab.
9. Remove the seat from the mounting plate.
10. Attach one pair of angle mount brackets to the 11000 mounting plate using four 3/8" x 3/4" carriage bolts and flange nuts. Hand tighten only.
11. Mount the other pair of angle mount brackets to the seat using four 3/8" x 3/4" carriage bolts and flange nuts. Hand tighten only.

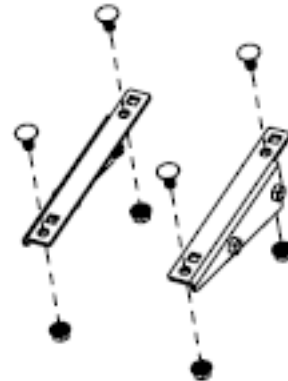
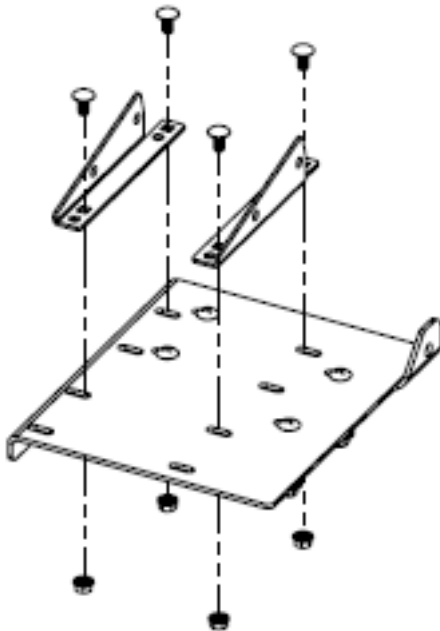

12. Make sure the 3" and 4" carriage bolts are in the 11000 mounting plate per step 4.
13. Fasten the two pairs of angle brackets together using 3/8" x 3/4" bolts and flange nuts. Note: the angle brackets on the seat go on the outside of the angle brackets on the 11000 mounting plate.
14. Tighten the carriage bolts holding the angle brackets to the seat and the bolts holding that angle brackets to the 11000 mounting plate.
15. Insert the seat mounting bolts into the spacers and through the cab fender. Fasten with flat washer and flange nut on the bottom side of the fender. Insert the seat mounting bolts into the spacers and through the cab fender. Fasten with flat washer and lock nut on the bottom side of the fender.
16. Install the seat belt assembly on the seat mounting plate with bolts supplied in the seat belt kit.

