



# Truck Winch Quick Mounting Plate

## Owner's Manual



**⚠ WARNING:** Read carefully and understand all ASSEMBLY AND OPERATION INSTRUCTIONS before operating. Failure to follow the safety rules and other basic safety precautions may result in serious personal injury.

Item #54130

**SAVE THESE INSTRUCTIONS**

Thank you very much for choosing an Ironton™ product!

For future reference, please complete the owner's record below:

Serial Number/Lot Date Code: \_\_\_\_\_

Purchase Date: \_\_\_\_\_

Save the receipt, warranty, and this manual. It is important that you read the entire manual to become familiar with this product before you begin using it.

This mounting plate is designed for certain applications only. Northern Tool & Equipment is not responsible for issues arising from modification or improper use of this product such as an application for which it was not designed. We strongly recommend that this product not be modified and/or used for any application other than that for which it was designed.

For technical questions, please call **1-800-222-5381**.

**Table of Contents**

**Intended Use.....4**

**Important Safety Information .....4**

**Specific Operation Warnings .....5**

**Safety Label .....5**

**Main Parts of Product .....6**

**Assembly Instructions.....6**

**Operating Instructions.....7**

**Before Each Use.....8**

**After Each Use.....8**

**Maintenance .....8**

**Parts Diagram .....9**

**Parts List.....9**

**Replacement Parts .....9**

**Limited Warranty.....10**

## Intended Use

The Ironton Truck Winch Quick Mounting Plate handles most vehicle winches with a capacity up to 12000 lbs. Made of welded carbon steel construction, it fits a standard 2 inch receiver tube. This winch mount makes it easy to install a winch with your existing receiver tube. The durable carbon steel construction allows your truck to handle winches with capacities up to 12,000 lb.

Property	Specification
Rated Capacity	1,200 lb.
Construction	Welded Carbon Steel
Receiver Tube	Fits 2" Standard

## Important Safety Information

### **⚠WARNING**

- Read and understand all instructions. Failure to follow all instructions may result in fire, serious injury and /or DEATH.
- The warnings, cautions, and instructions in this manual cannot cover all possible conditions or situations that could occur. Exercise common sense and caution when using this mounting plate. Always be aware of the environment and ensure that the tool is used in a safe and responsible manner.
- Do not allow persons to operate or assemble the mounting plate until they have read this manual and have developed a thorough understanding of how it works.
- Do not modify this mounting plate in any way. Unauthorized modification may impair the function and/or safety and could affect the life of the product. There are specific applications for which the product was designed.
- Use the right tool for the job. DO NOT attempt to force small equipment to do the work of larger industrial equipment. There are certain applications for which this equipment was designed. The tool will be a safer and do the job better at the capacity for which it was intended. DO NOT use this equipment for a purpose for which it was not intended.

### **⚠WARNING**

This winch may contain chemicals known to the State of California to cause cancer, birth defects or other reproductive harm.

### **⚠WARNING**

#### **WORK AREA SAFETY**

- Inspect the work area before each use. Keep work area clean, dry, free of clutter, and well-lit. Cluttered, wet, or dark work areas can result in injury. Using the mounting plate in confined work areas may put you dangerously close to other cutting tools and rotating parts.
- Keep children and bystanders away from the work area while operating the tool. Do not allow children to handle the mounting plate.

## **⚠WARNING**

### **PERSONAL SAFETY**

- Stay alert, watch what you are doing, and use common sense when operating the mounting plate. Do not use the tool while you are tired or under the influence of drugs, alcohol, or medication. A moment of inattention while operating the tool may result in serious personal injury.
- Dress properly. Do not wear loose clothing, dangling objects, or jewelry. Keep your hair, clothing and gloves away from moving parts. Loose clothes, jewelry, or long hair can be caught in moving parts. Air vents on the tool often cover moving parts and should be avoided.
- Wear the proper personal protective equipment when necessary. Use ANSI Z87.1 compliant safety goggles (not safety glasses) with side shields, or when needed, a face shield. Use a dust mask in dusty work conditions. Also use non-skid safety shoes, hardhat, gloves, dust collection systems, and hearing protection when appropriate. This applies to all persons in the work area.
- Do not overreach. Keep proper footing and balance at all times.
- Do not use the tool when tired or under the influence of drugs, alcohol or medication.

## **⚠CAUTION**

### **MOUNTING PLATE USE AND CARE**

- Do not force the mounting plate. Products are safer and do a better job when used in the manner for which they are designed. Plan your work, and use the correct product for the job.
- Check for damaged parts before each use. Carefully check that the product will operate properly and perform its intended function. Replace damaged or worn parts immediately. Never operate the product with a damaged part.

## **Specific Operation Warnings**

## **⚠WARNING**

- Do not exceed the 12,000 lb. pull capacity.
- Be aware of dynamic loading! Sudden load movement may briefly create excess load causing product failure. Capacity limited by hitch mounted on. Obey DOT and local regulations for use on public roads.
- Read the winch manual and manual for the hitch receiver that this is mounted in before setting up.
- Route the cable through the fairlead slot and pull straight back only.
- Weight capacity and other product capabilities apply to properly and completely assembled product only.

## **Safety Label**

### **CAUTION!**

1. This bracket is available for electric winch capacity from 8000LB to 13000LB.
2. Please mount it tightly to vehicle and winch.

## Main Parts of Product

Reference	Subassembly
1	Short Handle
2	Long Handle
3	Base Plate

## Assembly Instructions

### ⚠WARNING

- Read the entire Important Safety Information section at the beginning of this manual including all text under subheadings therein before set up or use of this project.
- Assemble only according to these instructions. Improper assembly can create hazards
- Keep assembly area clean and well lit.
- Keep bystanders out of the area during assembly.
- Do not drill new holes to attach winch to mount or weld winch to mount.

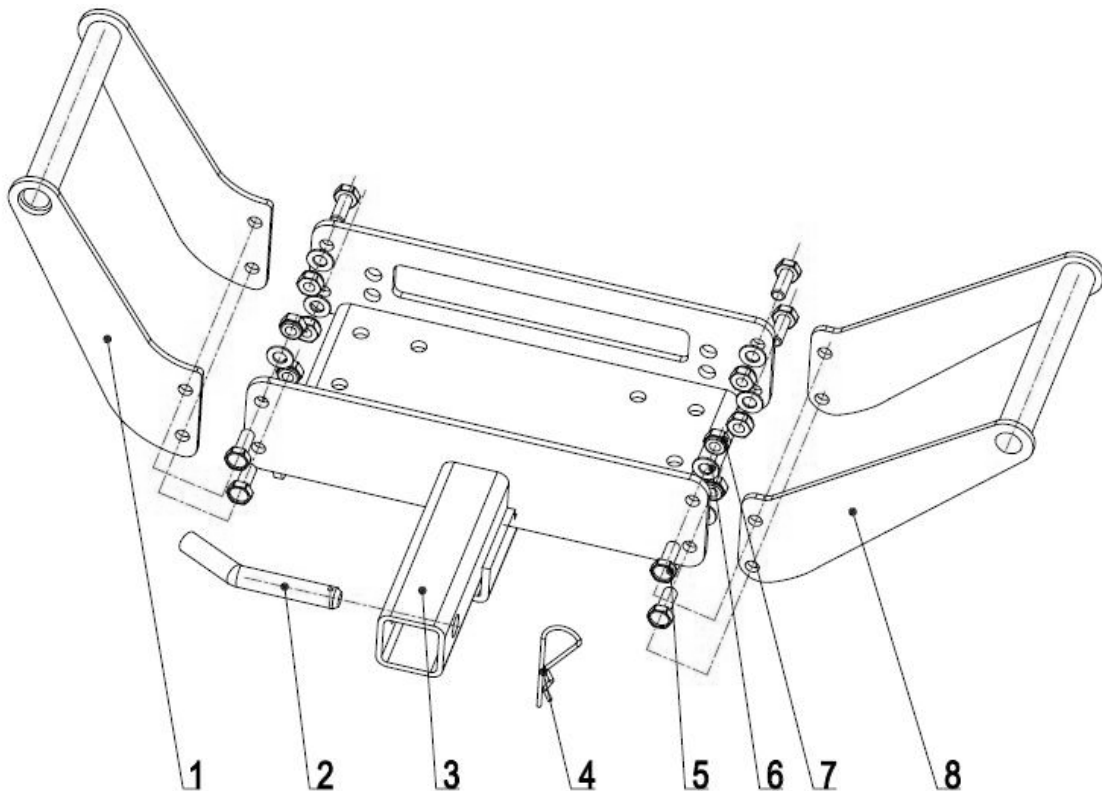

1. Take the winch cradle out of the carton.
2. Insert the mount into the receiver of the vehicle. Secure the winch cradle and winch by inserting the linch pin through the holes.
3. Assemble the winch on the winch cradle with bolt and nut.

**Note:** Some parts are listed and shown for illustration purposes only, and are not available individually as replacement parts.

## Operating Instructions

1. Attach the winch to the quick mount plate. Fasten with four bolts and nuts (Pic A).

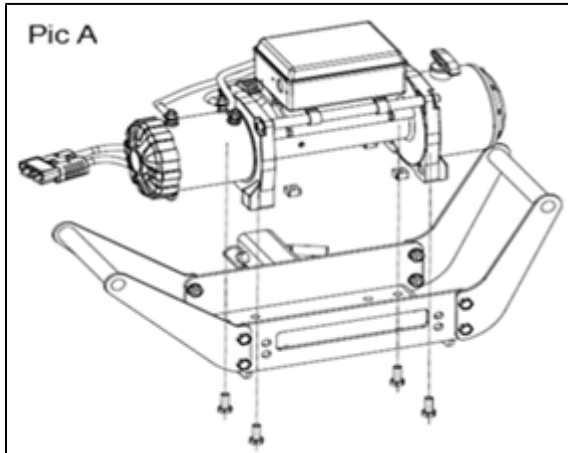

2. Attach the roller fairlead to the side of mount plate. Fasten with bolts and nuts (Pic B).

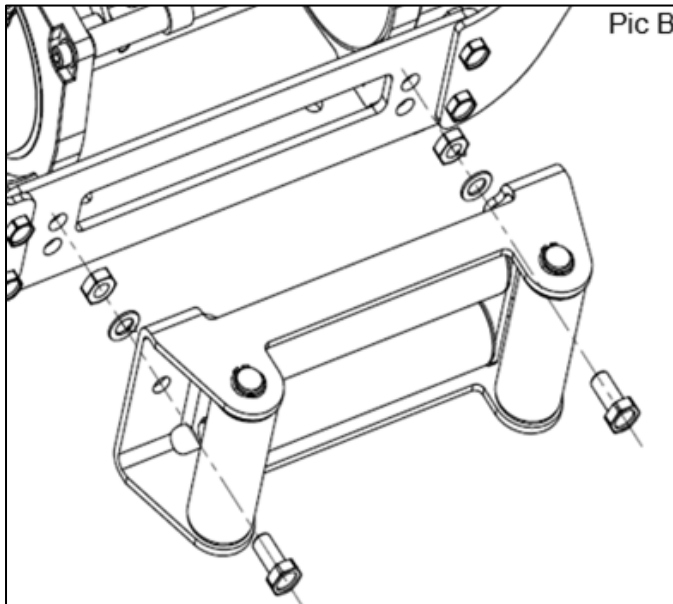

3. Use the hitch pin (#2) and hitch clip (#4) to connect the winch and mount plate to the receiver hitch (Pic C).

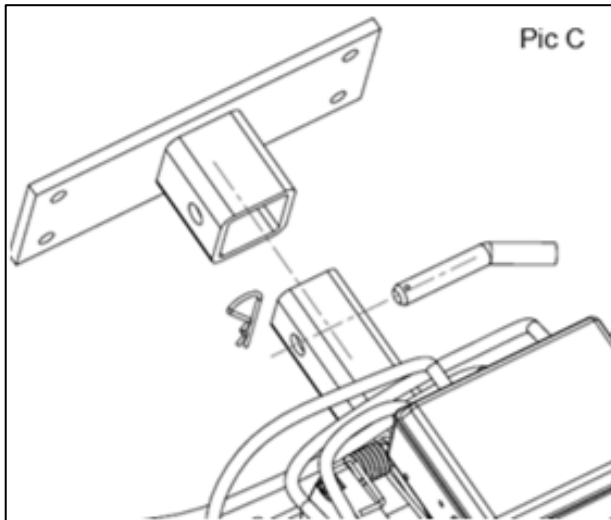

### Before Each Use

#### **⚠WARNING**

Always check for damaged part before every use.

### After Each Use

#### **⚠WARNING**

- Store it in a dry, secure place out of the reach of children.
- Inspect the tool for good working condition prior to storage and before re-use

### Maintenance

#### **⚠WARNING**

Maintain product labels and nameplates. These carry important safety information.



## Parts Diagram

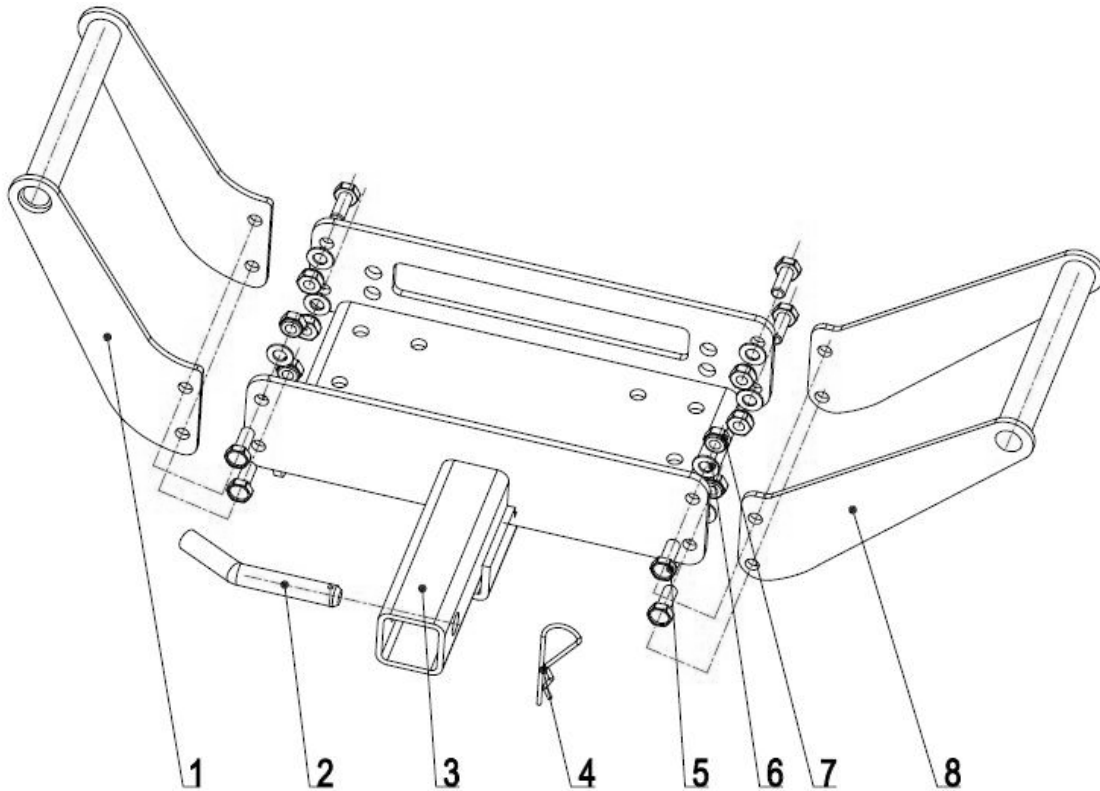

## Parts List

Part Number	Description	Quantity
1	Short Handle	1
2	Hitch Pin	1
3	Baseplate	1
4	Hitch Clip	1
5	Screw Bolt	8
6	Flat Washer	8
7	Screw Nut	8
8	Long Handle	1

## Replacement Parts

- For replacement parts and technical questions, please call Customer Service at **1-800-222-5381**.
- Not all product components are available for replacement. The illustrations provided are a convenient reference to the location and position of parts in the assembly sequence.
- When ordering parts, the following information will be required: item description, item model number, item serial number/item lot date code, and the replacement part number.
- The distributor reserves the rights to make design changes and improvements to product lines and manuals without notice.

## Limited Warranty

Northern Tool and Equipment Company, Inc. ("We" or "Us") warrants to the original purchaser only ("You" or "Your") that the Ironton product purchased will be free from material defects in both materials and workmanship, normal wear and tear excepted, for a period of one year from date of purchase. The foregoing warranty is valid only if the installation and use of the product is strictly in accordance with product instructions. There are no other warranties, express or implied, including the warranty of merchantability or fitness for a particular purpose. If the product does not comply with this limited warranty, Your sole and exclusive remedy is that We will, at our sole option and within a commercially reasonable time, either replace the product or product component without charge to You or refund the purchase price (less shipping). This limited warranty is not transferable.

### Limitations on the Warranty

This limited warranty does not cover: (a) normal wear and tear; (b) damage through abuse, neglect, misuse, or as a result of any accident or in any other manner; (c) damage from misapplication, overloading, or improper installation; (d) improper maintenance and repair; and (e) product alteration in any manner by anyone other than Us, with the sole exception of alterations made pursuant to product instructions and in a workmanlike manner.

### Obligations of Purchaser

You must retain Your product purchase receipt to verify date of purchase and that You are the original purchaser. To make a warranty claim, contact Us at 1-800-222-5381, identify the product by make and model number, and follow the claim instructions that will be provided. The product and the purchase receipt must be provided to Us in order to process Your warranty claim. Any returned product that is replaced or refunded by Us becomes our property. You will be responsible for return shipping costs or costs related to Your return visit to a retail store.

### Remedy Limits

Product replacement or a refund of the purchase price is Your sole remedy under this limited warranty or any other warranty related to the product. We shall not be liable for: service or labor charges or damage to Your property incurred in removing or replacing the product; any damages, including, without limitation, damages to tangible personal property or personal injury, related to Your improper use, installation, or maintenance of the product or product component; or any indirect, incidental or consequential damages of any kind for any reason.

### Assumption of Risk

You acknowledge and agree that any use of the product for any purpose other than the specified use(s) stated in the product instructions is at Your own risk.

### Governing Law

This limited warranty gives You specific legal rights, and You also may have other rights which vary from state to state. Some states do not allow limitations or exclusions on implied warranties or incidental or consequential damages, so the above limitations may not apply to You. This limited warranty is governed by the laws of the State of Minnesota, without regard to rules pertaining to conflicts of law. The state courts located in Dakota County, Minnesota shall have exclusive jurisdiction for any disputes relating to this warranty.



Distributed by:

Northern Tool & Equipment Company, Inc.

Burnsville, Minnesota 55306

[www.northerntool.com](http://www.northerntool.com)

Made in China