



1/8 HP Mini Air Mover

Owner's Manual



⚠ WARNING: Read carefully and understand all ASSEMBLY AND OPERATION INSTRUCTIONS before operating. Failure to follow the safety rules and other basic safety precautions may result in serious personal injury.

Item #52724

READ AND SAVE THESE INSTRUCTIONS

Thank you very much for choosing an Ironton™ product!

For future reference, please complete the owner's record below:

Serial Number/Lot Date Code: _____

Purchase Date: _____

Save the receipt, warranty, and this manual. It is important that you read the entire manual to become familiar with this product before you begin using it.

This 1/8 HP Mini Air Mover is designed for certain applications only. Northern Tool & Equipment is not responsible for issues arising from modification or improper use of this product such as an application for which it was not designed. We strongly recommend that this product not be modified and/or used for any application other than that for which it was designed.

For technical questions, please call **1-800-222-5381**.

Table of Contents

Intended Use.....4

Technical Specifications4

Important Safety Information4

Specific Operating Warnings6

Grounding6

Assembly Instructions.....8

Before Each Use.....8

Operating Instructions.....8

After Each Use.....8

Maintenance8

Troubleshooting9

Parts Diagram.....9

Parts List.....9

Replacement Parts10

Limited Warranty.....11

Intended Use

Ironton's 1/8 HP Mini Air Mover is intended to move air to dry floors, walls, furniture, and a variety of other areas. It's durable and easy to operate with an effective balance of static pressure and airflow.

Technical Specifications

Model	Item #52724
Volt / Frequency	115 Volts / 60 Hz
Power	1/8 HP
Amp	1.5 Amps
Rated Airflow (on High)	500 CFM
RPM (Low/Medium/High)	650/950/1200
Speeds	3 Speeds

Important Safety Information

⚠WARNING

- Read and understand all instructions. Failure to follow all instructions may result in serious injury or property damage.
- The warnings, cautions, and instructions in this manual cannot cover all possible conditions or situations that could occur. Exercise common sense and caution when using this air mover. Always be aware of the environment and ensure that the air mover is used in a safe and responsible manner.
- Do not allow persons to operate or assemble the air mover until they have read this manual and have developed a thorough understanding of how it works.
- Do not modify this air mover in any way. Unauthorized modification may impair the function and/or safety and could affect the life of the air mover. There are specific applications for which the air mover was designed.
- Use the right tool for the job. DO NOT attempt to force small equipment to do the work of larger industrial equipment. There are certain applications for which this equipment was designed. The product will be safer and do a better job at the capacity for which it was intended. DO NOT use this equipment for a purpose for which it was not intended.
- Industrial or commercial applications must follow OSHA requirements.

⚠WARNING

WORK AREA SAFETY

- Inspect the work area before each use. Keep work area clean, dry, free of clutter, and well lit. Cluttered, wet, or dark work areas can result in injury. Using the air mover in confined work areas may put you dangerously close to other cutting tools and rotating parts.
- Do not use the air mover where there is a risk of causing a fire or an explosion; e.g., in the presence of flammable liquids, gases, or dust. The air mover can create sparks, which may ignite the flammable liquids, gases, or dust.
- Keep children and bystanders away from the work area while operating the air mover. Do not

allow children to handle the air mover.

- Be aware of all power lines, electrical circuits, water pipes, and other mechanical hazards in your work area. Some of these hazards may be hidden from your view and may cause personal injury and/or property damage if contacted.

⚠WARNING

PERSONAL SAFETY

- Stay alert, watch what you are doing, and use common sense when operating the air mover. Do not use the air mover while you are tired or under the influence of drugs, alcohol, or medication. A moment of inattention while operating the air mover may result in serious personal injury.
- Dress properly. Do not wear loose clothing, dangling objects, or jewelry. Keep your hair, clothing and gloves away from moving parts. Loose clothes, jewelry, or long hair can be caught in moving parts. Air vents on the air mover often cover moving parts and should be avoided.
- Wear the proper personal protective equipment when necessary. Use ANSI Z87.1 compliant safety goggles (not safety glasses) with side shields, or when needed, a face shield. Use a dust mask in dusty work conditions. Also use non-skid safety shoes, hardhat, gloves, dust collection systems, and hearing protection when appropriate. This applies to all persons in the work area.
- Do not overreach. Keep proper footing and balance at all times.
- Ensure the power switch is off prior to plugging in the air mover.

⚠WARNING

ELECTRICAL SAFETY

- Grounded tools must be plugged into an outlet properly installed and grounded in accordance with all codes and ordinances. Never remove the grounding prong or modify the plug in any way. Do not use any adapter plugs. Check with a qualified electrician if you are in doubt as to whether the outlet is properly grounded. If the air mover should electrically malfunction or break down, grounding provides a low resistance path to carry electricity away from the user.
- Double insulated tools are equipped with a polarized plug (one blade is wider than the other). This plug will fit in a polarized outlet only one way. If the plug does not fit fully in the outlet, reverse the plug. If it still does not fit, contact a qualified electrician to install a polarized outlet. Do not change the plug in any way. Double insulation eliminates the need for the three wire grounded power cord and grounded power supply system.
- Avoid body contact with grounded surfaces such as pipes, radiators, ranges, and refrigerators. There is an increased risk of electric shock if your body is grounded.
- Do not expose power tools to rain or wet conditions. Water entering a power tool will increase the risk of electric shock.
- Do not abuse the power cord. Never use the power cord to carry the tools or pull the plug from an outlet. Keep the power cord away from heat, oil, sharp edges, or moving parts. Replace damaged power cords immediately. Damaged power cords increase the risk of electric shock.

⚠CAUTION

AIR MOVER USE AND CARE

- Do not force the air mover. Products are safer and do a better job when used in the manner for which they are designed. Plan your work, and use the correct product for the job.
- Check for damaged parts before each use. Carefully check that the air mover will operate properly and perform its intended function. Replace damaged or worn parts immediately. Never operate the air mover with a damaged part.
- Do not use an air mover with a malfunctioning switch. Any power tool that cannot be controlled with the power switch is dangerous and must be repaired by an authorized service representative before using.
- Disconnect the power/air supply from the product and place the switch in the locked or off position before making any adjustments, changing accessories, or storing the air mover. Such preventive safety measures reduce the risk of starting the tool accidentally.
- Store the air mover when it is not in use. Store it in a dry, secure place out of the reach of children. Inspect the air mover for good working condition prior to storage and before re-use.
- Use only accessories that are recommended by the manufacturer for use with your air mover. Accessories that may be suitable for one product may create a risk of injury when used with another tool. Never use an accessory that has a lower operating speed or operating pressure than the tool itself.

Specific Operating Warnings

⚠WARNING

- Electric shock hazard. DO NOT expose the unit to water.
- Risk of electric shock. Connect to a properly grounded outlet equipped with a ground fault circuit interruption device (GFCI).
- Risk of fire. DO NOT operate in areas with flammable fumes. The fumes can spark, igniting fumes.
- DO NOT run the cord under carpeting. DO NOT cover the cord with throw rugs, runners, or similar coverings.
- DO NOT route the cord under furniture or appliances. Arrange the cord away from traffic area and where it will not be tripped over.
- DO NOT allow more than six blowers to be connected to each other at one time.
- DO NOT use an extension cord.
- Disconnect from the power supply before servicing.
- DO NOT block the air inlet or exhaust.
- DO NOT modify the grounded plug.
- DO NOT use if the cord or other parts are damaged.

Grounding

⚠WARNING

- This air mover must be grounded while in use to protect the operator from electrical shock. The

plug **MUST** be plugged into a matching receptacle that is properly installed and grounded in accordance with ALL local codes and ordinances.

- **DO NOT MODIFY THE PROVIDED PLUG.** If it will not fit the receptacle, have the proper receptacle installed by a qualified electrician.
- **CHECK** with a qualified electrician or service person if you do not completely understand the grounding instructions, or if you are not sure the tool is properly grounded.

Grounded Tools: Tools with 3-Prong Plugs

Tools marked with “**Grounding Required**” have a 3-wire cord and 3-prong grounding plug. The plug must be connected to a properly grounded outlet. If the air mover should electrically malfunction or break down, grounding provides a low resistance path to carry electricity away from the user, reducing the risk of electric shock. (See Figure A.)

The grounding prong in the plug is connected through the green wire inside the cord to the grounding system in the air mover. The green wire in the cord must be the only wire connected to the tool’s grounding system and must never be attached to an electrically live terminal.

Your air mover must be plugged into an appropriate outlet, properly installed and grounded in accordance with all codes and ordinances. The plug and outlet should look like those in the following illustration.

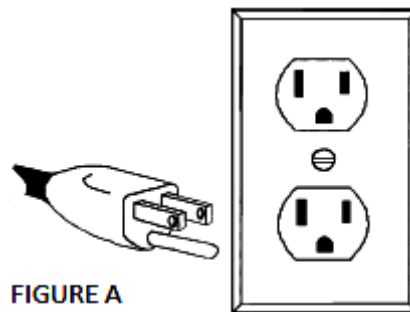

FIGURE A

Double Insulated Tools: Tools with Two-Prong Plugs

Tools marked “**Double Insulated**” do not require grounding. They have a special double insulation system which satisfies OSHA requirements and complies with the applicable standards of Underwriters Laboratories, Inc., the Canadian Standard Association, and the National Electrical Code. (See Figure B.)

Double insulated tools may be used in either of the 120 volt outlets shown in the following illustration.

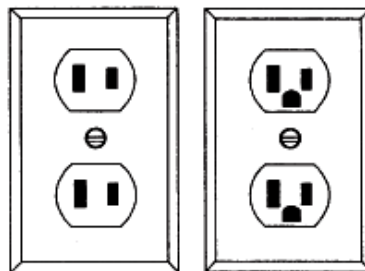

FIGURE B

Assembly Instructions

IRONTON's #52724 Air Mover is shipped ready-to-use. Prior to plugging the unit into the power source, completely inspect it for any shipping damage.

Before Each Use

⚠WARNING

- Always inspect power cords for damage before operating.
- All air movers in operation must be supervised at all times.

Operating Instructions

1. Plug the electrical cord into the power outlet. To reduce the risk of electric shock, connect only to an outlet provided with a Ground Fault Circuit Interrupter device.
2. Carefully place the air mover on a stable, flat, dry surface.
3. The unit has four position capabilities to aim airflow across flat surfaces or to angle upward.
4. Turn the switch to select the desired speed, making sure the unit operates normally.

After Each Use

Always disconnect the air mover from its power source and wrap the cord around handle. When it's not in use, store the air mover in a dry, indoor space out of reach of children. Air movers can be stacked up to 6 on their sides for storage. (The stacking feature is not secure for transportation.)

Maintenance

⚠WARNING

- NEVER clean the air mover directly with water.
- ALWAYS disconnect the air mover from its power source before performing any maintenance or cleaning.

Maintain the Air Mover by adopting a program of conscientious repair and maintenance in accordance with the following recommended procedures. It is recommended that the general condition of any tool be examined before it is used. Keep your tool in good repair.

Troubleshooting

Use the table below to troubleshoot problems before contacting service personnel or your local dealer. If the problem continues after troubleshooting, call your local dealer for assistance.

Failure	Possible Cause	Corrective Action
Air mover is not running.	No power input.	Plug in the air mover. Check the circuit breaker.
	Switch is not turned on.	Turn the switch to "on".
	Air mover fan has a wheel jammed.	Remove any material jamming the fan wheel.
	Intake or exhaust is blocked.	Turn the unit off and allow it to cool. Remove the blockage.
	Accumulation of dirt on fan blades.	Clean the air mover fan blades.

Parts Diagram

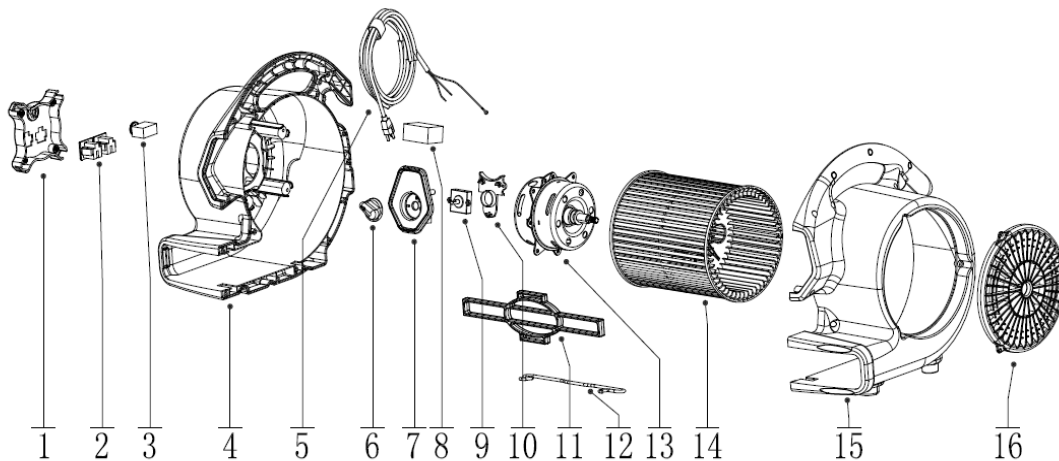

Parts List

Reference	Part Name
1	Grid Cover (Motor Side)
2	Receptacles
3	Over-Current Protector
4	Left Housing
5	Power Cord
6	Switch Knob
7	Switch Panel
8	Capacitor
9	Switch
10	Pressure Block
11	Air Outlet Grid Cover
12	Kick Stand
13	Motor

Reference	Part Name
14	Fan
15	Right Housing
16	Grid Cover (Fan Side)

Replacement Parts

- For replacement parts and technical questions, please call Customer Service at **1-800-222-5381**.
- Not all product components are available for replacement. The illustrations provided are a convenient reference to the location and position of parts in the assembly sequence.
- When ordering parts, the following information will be required: item description, item model number, item serial number/item lot date code, and the replacement part reference number.
- The distributor reserves the rights to make design changes and or improvements to product lines and manuals without notice.

Limited Warranty

Northern Tool and Equipment Company, Inc. ("We" or "Us") warrants to the original purchaser only ("You" or "Your") that the Ironton product purchased will be free from material defects in both materials and workmanship, normal wear and tear excepted, for a period of one year from date of purchase. The foregoing warranty is valid only if the installation and use of the product is strictly in accordance with product instructions. There are no other warranties, express or implied, including the warranty of merchantability or fitness for a particular purpose. If the product does not comply with this limited warranty, Your sole and exclusive remedy is that We will, at our sole option and within a commercially reasonable time, either replace the product or product component without charge to You or refund the purchase price (less shipping). This limited warranty is not transferable.

Limitations on the Warranty

This limited warranty does not cover: (a) normal wear and tear; (b) damage through abuse, neglect, misuse, or as a result of any accident or in any other manner; (c) damage from misapplication, overloading, or improper installation; (d) improper maintenance and repair; and (e) product alteration in any manner by anyone other than Us, with the sole exception of alterations made pursuant to product instructions and in a workmanlike manner.

Obligations of Purchaser

You must retain Your product purchase receipt to verify date of purchase and that You are the original purchaser. To make a warranty claim, contact Us at 1-800-222-5381, identify the product by make and model number, and follow the claim instructions that will be provided. The product and the purchase receipt must be provided to Us in order to process Your warranty claim. Any returned product that is replaced or refunded by Us becomes our property. You will be responsible for return shipping costs or costs related to Your return visit to a retail store.

Remedy Limits

Product replacement or a refund of the purchase price is Your sole remedy under this limited warranty or any other warranty related to the product. We shall not be liable for: service or labor charges or damage to Your property incurred in removing or replacing the product; any damages, including, without limitation, damages to tangible personal property or personal injury, related to Your improper use, installation, or maintenance of the product or product component; or any indirect, incidental or consequential damages of any kind for any reason.

Assumption of Risk

You acknowledge and agree that any use of the product for any purpose other than the specified use(s) stated in the product instructions is at Your own risk.

Governing Law

This limited warranty gives You specific legal rights, and You also may have other rights which vary from state to state. Some states do not allow limitations or exclusions on implied warranties or incidental or consequential damages, so the above limitations may not apply to You. This limited warranty is governed by the laws of the State of Minnesota, without regard to rules pertaining to conflicts of law. The state courts located in Dakota County, Minnesota shall have exclusive jurisdiction for any disputes relating to this warranty.



Distributed by:

Northern Tool & Equipment Company, Inc.

Burnsville, Minnesota 55306

www.northerntool.com

Made in China