



Hydraulic Furniture Movers

Owner's Manual



⚠ WARNING: Read carefully and understand all ASSEMBLY AND OPERATION INSTRUCTIONS before operating. Failure to follow the safety rules and other basic safety precautions may result in serious personal injury.

Item #52397

SAVE THESE INSTRUCTIONS

Thank you very much for choosing a Strongway™ product!

For future reference, please complete the owner's record below:

Serial Number/Lot Date Code: _____

Purchase Date: _____

Save the receipt, warranty, and this manual. It is important that you read the entire manual to become familiar with this product before you begin using it.

This Hydraulic Furniture Movers set is designed for certain applications only. Northern Tool & Equipment is not responsible for issues arising from modification or improper use of this product such as an application for which it was not designed. We strongly recommend that this product not be modified and/or used for any application other than that for which it was designed.

For technical questions, please call **1-800-222-5381**.

Table of Contents

Intended Use.....	4
Technical Specifications	4
Important Safety Information	4
Specific Operation Warnings	6
Assembly Instructions.....	6
Operating Instructions.....	6
Maintenance	7
Parts Diagram.....	8
Parts List.....	9
Replacement Parts	10
Limited Warranty.....	11

Intended Use

The Hydraulic Furniture Mover set is designed for lifting and transporting cabinets and other large pieces of furniture. Its supports are covered with foam rubber to protect furniture from damage.

Since the furniture mover consists of two units, rectangular objects of varying length can be moved using minimum space. Due to the weight of the cabinet on the platform, it will hold itself in position when the units are standing vertically and the frame of the platform is in contact with its sides.

If you operate the equipment properly, the furniture movers will help you move furniture quickly and safely.

Technical Specifications

Property	Specification
Rated Pair Capacity	3960 lbs.
Lift Height	10"
Lifting Plate Size	23.6" x 2.4"
Net Weight	189 lbs

Important Safety Information

⚠️WARNING

- Read and understand all instructions. Failure to follow all instructions may result in serious injury or property damage.
- The warnings, cautions, and instructions in this manual cannot cover all possible conditions or situations that could occur. Exercise common sense and caution when using this furniture mover. Always be aware of the environment and ensure that the furniture mover is used in a safe and responsible manner.
- Do not allow persons to operate or assemble the furniture mover until they have read this manual and have developed a thorough understanding of how it works.
- Do not modify this furniture mover in any way. Unauthorized modifications may impair the function and/or safety and could affect the life of the furniture mover. There are specific applications for which it was designed.
- Use the right tool for the job. DO NOT attempt to force small equipment to do the work of larger industrial equipment. There are certain applications for which this equipment was designed. It will be safer and do a better job at the capacity for which it was intended. DO NOT use this furniture mover for a purpose for which it was not intended.
- Industrial or commercial applications must follow OSHA requirements.

⚠️WARNING

WORK AREA SAFETY

- Inspect the work area before each use. Keep work area clean, dry, free of clutter, and well lit. Cluttered, wet, or dark work areas can result in injury. Using the furniture mover in confined work

areas may put you dangerously close to cutting tools and rotating parts.

- Do not allow the furniture mover to come into contact with an electrical source. The tool is not insulated and contact will cause electrical shock.
- Keep children and bystanders away from the work area while operating the furniture mover. Do not allow children to handle the furniture mover.
- Be aware of all power lines, electrical circuits, water pipes, and other mechanical hazards in your work area. Some of these hazards may be hidden from your view and may cause personal injury and/or property damage if contacted.

⚠WARNING

PERSONAL SAFETY

- Stay alert, watch what you are doing, and use common sense when operating the furniture mover. Do not use the furniture mover while you are tired or under the influence of drugs, alcohol, or medication. A moment of inattention while operating the equipment may result in serious personal injury.
- Dress properly. Do not wear loose clothing, dangling objects, or jewelry. Keep your hair, clothing and gloves away from moving parts. Loose clothes, jewelry, or long hair can be caught in moving parts. Air vents on the tool often cover moving parts and should be avoided.
- Wear the proper personal protective equipment when necessary. Use ANSI Z87.1 compliant safety goggles (not safety glasses) with side shields, or when needed, a face shield. Use a dust mask in dusty work conditions. Also use non-skid safety shoes, hardhat, gloves, dust collection systems, and hearing protection when appropriate. This applies to all persons in the work area.
- Do not overreach. Keep proper footing and balance at all times.

⚠CAUTION

MOVER USE AND CARE

- Do not force the furniture mover. Products are safer and do a better job when used in the manner for which they are designed. Plan your work, and use the correct product for the job.
- Check for damaged parts before each use. Carefully check that the mover will operate properly and perform its intended function. Replace damaged or worn parts immediately. Never operate the mover with a damaged part.
- Store the furniture mover when it is not in use. Store it in a dry, secure place out of the reach of children. Inspect it for good working condition prior to storage and before re-use.
- Use only accessories that are recommended by the manufacturer for use with your furniture mover. Accessories that may be suitable for one product may create a risk of injury when used with another tool. Never use an accessory that has a lower operating speed or operating pressure than the tool itself.

Specific Operation Warnings

⚠️WARNING

- Do not exceed loading capacity.
- Only use on a hard level surface.
- Ensure the load is secure by load constraining straps before moving.
- Do not use the if the height of the furniture exceeds 32 inches or if the units are less than 20 inches apart or more than 157 inches apart.
- Check both units for damage before operating the furniture mover. If there are visible defects, do not use the machine. Have any damaged parts replaced by a qualified service provider.
- Do not leave furniture unattended while raised up on the unit. Always lower the furniture on to the floor before leaving unattended.
- Never raise the furniture more than once inch off the floor.
- Always plan your route before moving furniture.
- Avoid any sudden movements.
- Never use the furniture mover for towing furniture behind a moving vehicle.
- Never operate the furniture mover alone. Two people are required to properly operate the unit.

Assembly Instructions

Remove the fork pin at the free end of the track rod, set the steering handles parallel to each other, and push the fork of the track rod over the arm of the steering handle. Then replace the previously removed fork pin through the fork and arm and secure it with a split ring.

The second unit is assembled in the same way.

Operating Instructions

Before using, the transport components should be checked for function, and for any damage. If there are visible defects, the components should not be used. Damaged parts must be replaced.

Since the hydraulic furniture mover consists of two parts, it is necessary for two people to operate it.

Before transporting cabinets, the platforms should be lowered to the floor until the transport units are standing vertically.

Push the platform of the units under the side faces (narrow faces) of the cabinet until the top and bottom of the transport platform frame are resting against it. The centers of the platform must be beneath the center of gravity of the cabinet.

Place the securing straps in position and tighten them. The straps will connect both units and, when used correctly, prevent them from slipping out of position. Here, the strap ends must be under direct tension. The straps must not be pulling around the edge of a cabinet, etc. If necessary, an additional strap surrounding it should be used. This must be fed through the strap loops on the units. However, the maximum overhang must not be more than 7 7/8".

The steering handles have a full lock of 180°, allowing goods to be transported in every direction. The platforms are raised by operating the lever of the pump; this lever must not be used for pulling or pushing the mover. The platform is lowered by twisting the manual release valve of the compact hydraulic system counter-clockwise. Great care must be taken when lowering the platform since the speed depends on the aperture of the valve as well as the weight of the goods to be transported. Before pumping up the system to raise the platforms, the valve must be twisted clockwise and closed.

Pump up the platform about 1 cm, and carefully check whether the cabinet to be transported is standing stably on the platforms. Adjustments may be needed.

Both platforms must be raised at the same time and to the same height. For the transport itself, the height off the floor must be a maximum of 2 cm only. When moving the cabinets, only push the transport units and choose the way to the cabinet's new position so that, if possible, it is only moved lengthwise. When moving cabinets sideways, always be very careful because of the great risk of the cabinets tilting over.



The cabinet being transported must not be left unattended on the equipment; it must always be lowered onto the floor.

The securing straps may only be opened when the cabinet is being transported or when the platform is standing on the floor.

Never tow the furniture mover behind a vehicle.

Maintenance

Maintain the furniture mover by adopting a program of conscientious repair and maintenance in accordance with the following recommended procedures. It is recommended that the general condition of any tool be examined before it is used. Keep your tool in good repair. Keep handles dry, clean, and free from oil and grease. The following chart is based on a normal operation schedule. The hydraulic furniture mover requires little care and maintenance, but this must be carried out regularly. Depending on its use, the spindles and gear wheels must be re-greased weekly or monthly.

Parts Diagram

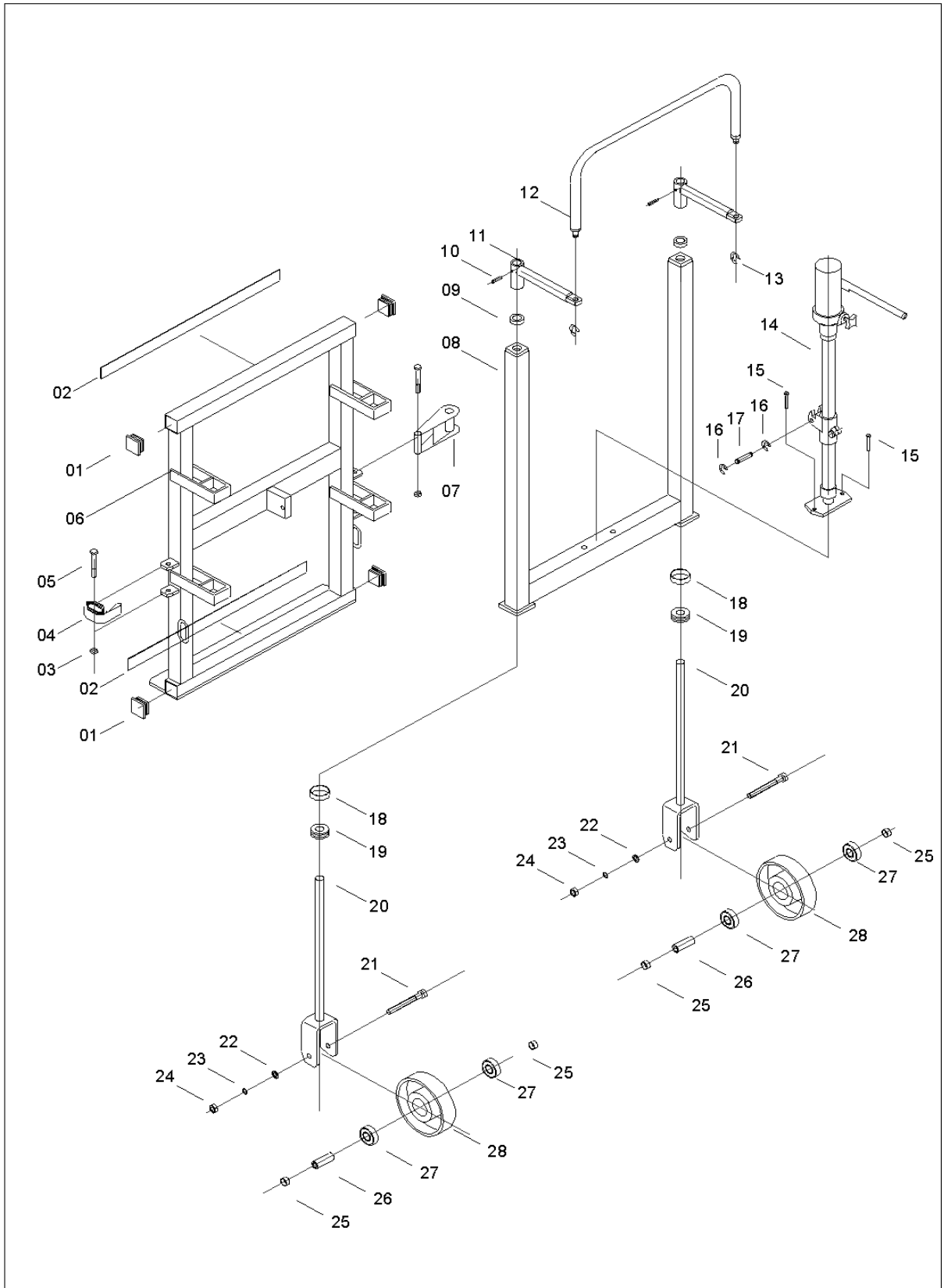

Parts List

Reference	Description	Qty
01	Dust-Proof Cover	4
02	Cushion	2
03	Lock Nut M10	2
04	Woven Stripe	1
05	Screw M10×70	2
06	Lifting Frame	1
07	Cargo Lashings	1
08	Supporting Frame	1
09	Nylon Washer	2
10	Cylindrical Spring Pin 6×30	2
11	Handle Assembly	2
12	Hand Tube	1
13	Split Ring 9	2
14	Hydraulic Jack	1
15	Screw M6×20	2
16	Split Ring 8	2
17	Pin	1
18	Dust-Proof Ring	2
19	Bearing 8204	2
20	Supporting Rod	2
21	Screw M12×85	2
22	Washer 12	2
23	Spring Washer 12	2
24	Nut M12	2
25	Bushing	4
26	Bushing	2
27	Bearing	2
28	Wheel	2

Replacement Parts

- For replacement parts and technical questions, please call Customer Service at **1-800-222-5381**.
- Not all product components are available for replacement. The illustrations provided are a convenient reference to the location and position of parts in the assembly sequence.
- When ordering parts, the following information will be required: item description, item model number, item serial number/item lot date code, and the replacement part reference number.
- The distributor reserves the rights to make design changes and or improvements to product lines and manuals without notice.

Limited Warranty

Northern Tool and Equipment Company, Inc. ("We" or "Us") warrants to the original purchaser only ("You" or "Your") that the Strongway product purchased will be free from material defects in both materials and workmanship, normal wear and tear excepted, for a period of one year from date of purchase. The foregoing warranty is valid only if the installation and use of the product is strictly in accordance with product instructions. There are no other warranties, express or implied, including the warranty of merchantability or fitness for a particular purpose. If the product does not comply with this limited warranty, Your sole and exclusive remedy is that We will, at our sole option and within a commercially reasonable time, either replace the product or product component without charge to You or refund the purchase price (less shipping). This limited warranty is not transferable.

Limitations on the Warranty

This limited warranty does not cover: (a) normal wear and tear; (b) damage through abuse, neglect, misuse, or as a result of any accident or in any other manner; (c) damage from misapplication, overloading, or improper installation; (d) improper maintenance and repair; and (e) product alteration in any manner by anyone other than Us, with the sole exception of alterations made pursuant to product instructions and in a workmanlike manner.

Obligations of Purchaser

You must retain Your product purchase receipt to verify date of purchase and that You are the original purchaser. To make a warranty claim, contact Us at 1-800-222-5381, identify the product by make and model number, and follow the claim instructions that will be provided. The product and the purchase receipt must be provided to Us in order to process Your warranty claim. Any returned product that is replaced or refunded by Us becomes our property. You will be responsible for return shipping costs or costs related to Your return visit to a retail store.

Remedy Limits

Product replacement or a refund of the purchase price is Your sole remedy under this limited warranty or any other warranty related to the product. We shall not be liable for: service or labor charges or damage to Your property incurred in removing or replacing the product; any damages, including, without limitation, damages to tangible personal property or personal injury, related to Your improper use, installation, or maintenance of the product or product component; or any indirect, incidental or consequential damages of any kind for any reason.

Assumption of Risk

You acknowledge and agree that any use of the product for any purpose other than the specified use(s) stated in the product instructions is at Your own risk.

Governing Law

This limited warranty gives You specific legal rights, and You also may have other rights which vary from state to state. Some states do not allow limitations or exclusions on implied warranties or incidental or consequential damages, so the above limitations may not apply to You. This limited warranty is governed by the laws of the State of Minnesota, without regard to rules pertaining to conflicts of law. The state courts located in Dakota County, Minnesota shall have exclusive jurisdiction for any disputes relating to this warranty.



Distributed by:

Northern Tool & Equipment Company, Inc.

Burnsville, Minnesota 55306

www.northerntool.com

Made in China