

JD 40 Series Cab Foam Kit - Early - PN: 4057

Early Cab Serial 4-185706 & Below ('78 & '79)

9 Pcs. - Black 64 HPSI

Material PN: 4008

(Headliner Complete Kit - Part No. 4508) (Corner Post Complete Kit - Part No. 4060)

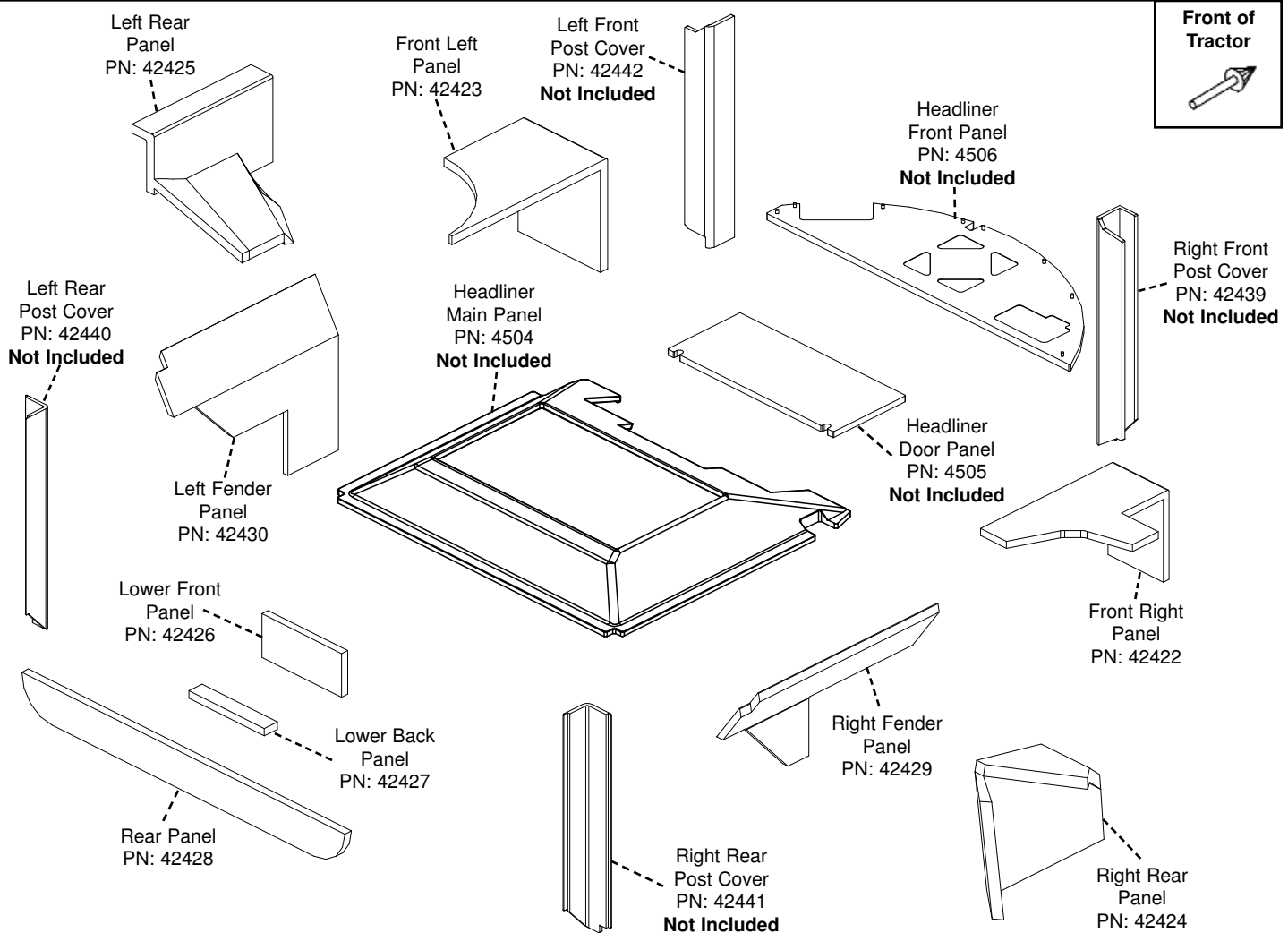

1. To make installation of your new cab foam kit easier, remove seat to allow more room to work. Also remove floor mat, ashtray, radio, AC and heater controls and vents in models where necessary.
2. **When removing the old foam, take note which pieces overlap each other as this will be important when installing your new cab foam kit.**
3. Remove existing foam and old glue residue as much as possible using a putty knife, wire brush, etc. If there is oil present on the walls of the cab, this must also be removed with a solvent. (Make sure this is done in a well ventilated area.)
4. Before gluing in the new pieces, dry fit them into their position first to see if any trimming is necessary. (Use a sharp utility knife to do any trimming.) When ready to install permanently, spray both the foam and the cab wall with adhesive. To prevent wrinkling, start gluing down one edge of the piece of foam and work your way to the opposite edge.



Phone - 800.328.1752

Fax - 320.329.3709

Email - sales@tractorseats.com

Web Site - www.tractorseats.com

P.O. Box 409 - 308 NW 2nd Street

Renville, MN 56284

JD 40 Series Cab Foam Kit - Late - PN: 4058

Late Cab Serial 4-185707 & Above (Late '79 to '82)

8 Pcs. - Black 64 HPSI

Material PN: 4008, 4103

(Headliner Complete Kit - Part No. 4508) (Corner Post Complete Kit - Part No. 4060)

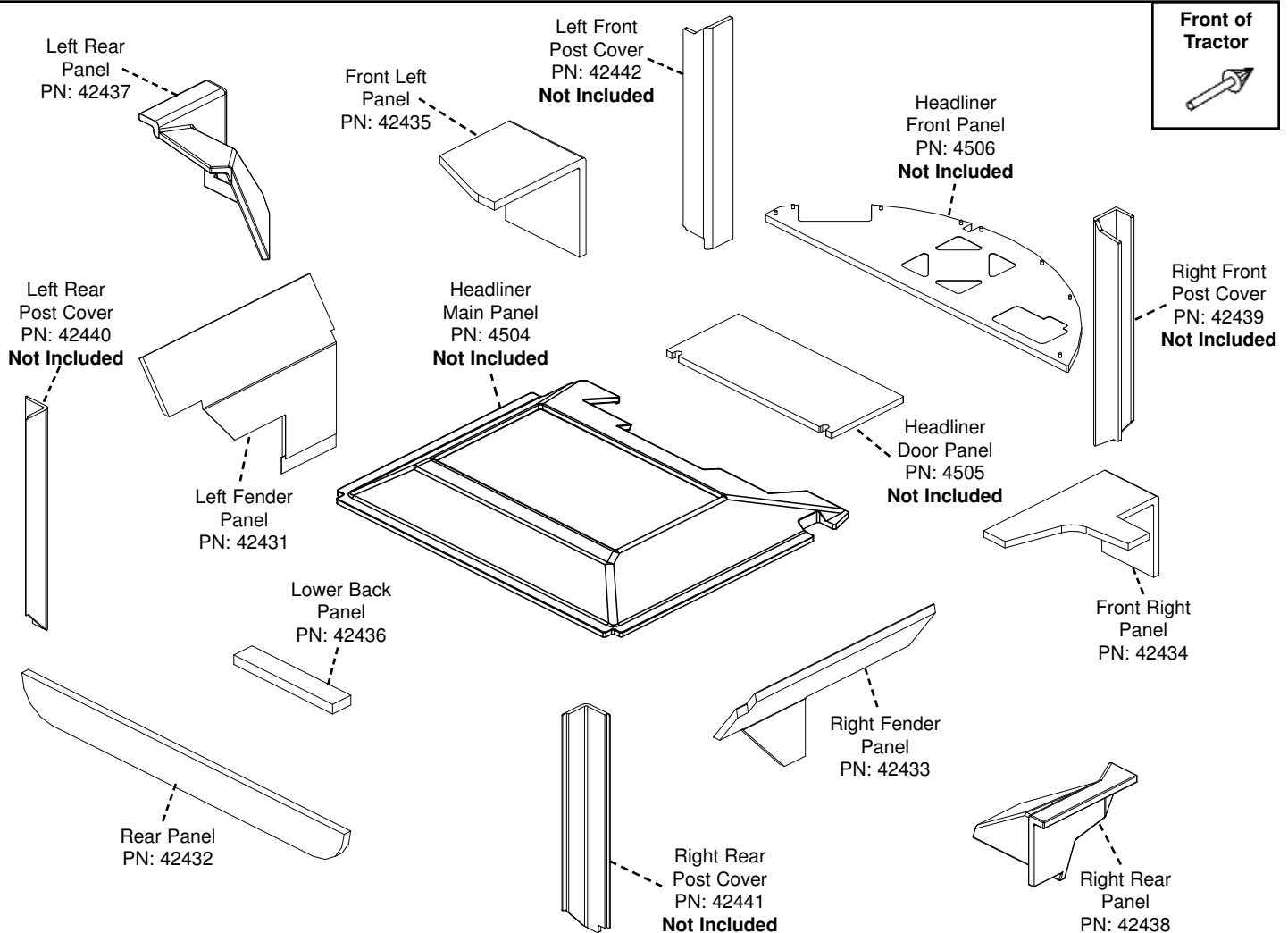

1. To make installation of your new cab foam kit easier, remove seat to allow more room to work. Also remove floor mat, ashtray, radio, AC and heater controls and vents in models where necessary.
2. **When removing the old foam, take note which pieces overlap each other as this will be important when installing your new cab foam kit.**
3. Remove existing foam and old glue residue as much as possible using a putty knife, wire brush, etc. If there is oil present on the walls of the cab, this must also be removed with a solvent. (Make sure this is done in a well ventilated area.)
4. Before gluing in the new pieces, dry fit them into their position first to see if any trimming is necessary. (Use a sharp utility knife to do any trimming.) When ready to install permanently, spray both the foam and the cab wall with adhesive. To prevent wrinkling, start gluing down one edge of the piece of foam and work your way to the opposite edge.



Phone - 800.328.1752

Fax - 320.329.3709

Email - sales@tractorseats.com

Web Site - www.tractorseats.com

P.O. Box 409 - 308 NW 2nd Street

Renville, MN 56284