

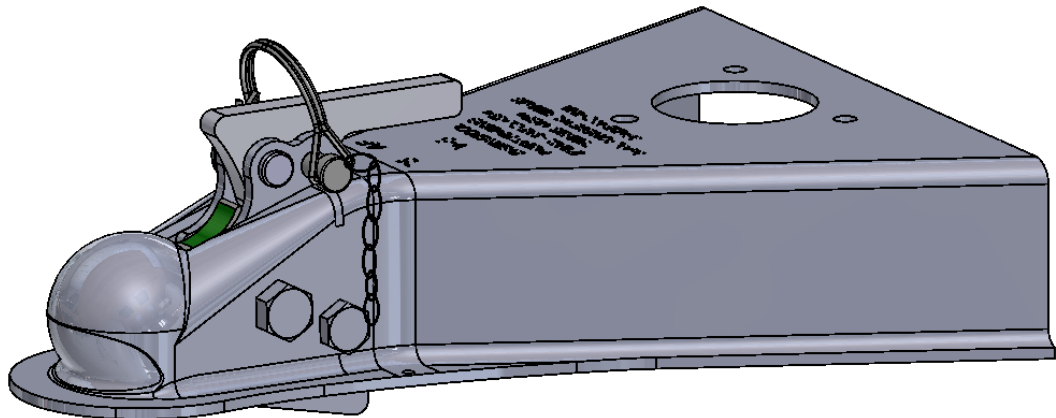

Auto Locking A-Frame Trailer Coupler

5000 Lb. Capacity

Owner's Manual



⚠ WARNING: Read carefully and understand all ASSEMBLY AND OPERATION INSTRUCTIONS before operating. Failure to follow the safety rules and other basic safety precautions may result in serious personal injury.

Item #54547

SAVE THESE INSTRUCTIONS

Thank you very much for choosing an Ultra-Tow™ product!

For future reference, please complete the owner's record below:

Serial Number/Lot Date Code: _____

Purchase Date: _____

Save the receipt, warranty, and this manual. It is important that you read the entire manual to become familiar with this product before you begin using it.

This Auto Locking A-Frame Trailer Coupler is designed for certain applications only. Northern Tool and Equipment is not responsible for issues arising from modification or improper use of this product such as an application for which it was not designed. We strongly recommend that this product not be modified and/or used for any application other than that for which it was designed.

For technical questions, please call **1-800-222-5381**.

Table of Contents

Intended Use.....4

Technical Specifications4

Important Safety Information4

Specific Operation Warnings6

Towing.....6

Installation Instruction.....6

Before Each Use.....7

Operating Instructions.....7

After Each Use.....9

Maintenance9

Troubleshooting.....10

Parts Diagram11

Parts List11

Replacement Parts12

Limited Warranty13

Intended Use

This Ultra-Tow XTP Series Auto Locking A-Frame Trailer Coupler features an auto-locking system with a steel lock assembly. The secondary lock has a safety clip designed to fit an off-the-shelf padlock without an adaptor. This coupler can be used with any 2" ball having a capacity rating equal to or higher than the coupler.

Technical Specifications

Property	Specification
Max. Gross Trailer Weight	2.5 Ton (5,000 lb.)
Max. Vertical Load	0.375 Ton (750 lb.)
Product Weight	7.5 lb.
Total Length	13.5"
Material	Steel
Coupler Width	A-Frame
Mounting	Weld On
Hitch Ball Diameter	2"
Max. Gross Trailer Weight	Stamped on Hitch Ball

Important Safety Information

⚠WARNING

- Read and understand all instructions. Failure to follow all instructions may result in serious injury or property damage.
- The warnings, cautions, and instructions in this manual cannot cover all possible conditions or situations that could occur. Exercise common sense and caution when using this coupler. Always be aware of the environment and ensure that the tool is used in a safe and responsible manner.
- Do not allow persons to operate or assemble the coupler until they have read this manual and have developed a thorough understanding of how it works.
- Do not modify this coupler in any way. Unauthorized modification may impair the function and/or safety and could affect the life of the product. There are specific applications for which the product was designed.
- Use the right tool for the job. DO NOT attempt to force small equipment to do the work of larger industrial equipment. There are certain applications for which this equipment was designed. This product will be safer and do a better job at the capacity for which it was intended. DO NOT use this equipment for a purpose for which it was not intended.
- Industrial or commercial applications must follow OSHA requirements.

⚠WARNING

WORK AREA SAFETY

- Inspect the work area before each use. Keep work area clean, dry, free of clutter, and well-lit. Cluttered, wet, or dark work areas can result in injury. Using the product in confined work areas

may put you dangerously close to other cutting tools and rotating parts.

- Do not use the coupler where there is a risk of causing a fire or an explosion; e.g., in the presence of flammable liquids, gases, or dust. The product can create sparks, which may ignite the flammable liquids, gases, or dust.
- Do not allow the coupler to come into contact with an electrical source. The tool is not insulated and contact will cause electrical shock.
- Keep children and bystanders away from the work area while operating the tool. Do not allow children to handle the product.

⚠WARNING

PERSONAL SAFETY

- Stay alert, watch what you are doing, and use common sense when operating the tool. Do not use the tool while you are tired or under the influence of drugs, alcohol, or medication. A moment of inattention while operating the tool may result in serious personal injury.
- Dress properly. Do not wear loose clothing, dangling objects, or jewelry. Keep your hair, clothing and gloves away from moving parts. Loose clothes, jewelry, or long hair can be caught in moving parts. Air vents on the tool often cover moving parts and should be avoided.
- Wear the proper personal protective equipment when necessary. Use ANSI Z87.1 compliant safety goggles (not safety glasses) with side shields, or when needed, a face shield. Use a dust mask in dusty work conditions. Also use non-skid safety shoes, hardhat, gloves, dust collection systems, and hearing protection when appropriate. This applies to all persons in the work area.
- Do not overreach. Keep proper footing and balance at all times.

⚠CAUTION

COUPLER USE AND CARE

- Do not force the coupler. Products are safer and do a better job when used in the manner for which they are designed. Plan your work, and use the correct product for the job.
- Check for damaged parts before each use. Carefully check that the product will operate properly and perform its intended function. Replace damaged or worn parts immediately. Never operate the product with a damaged part.
- Store the product when it is not in use. Store it in a dry, secure place out of the reach of children. Inspect the tool for good working condition prior to storage and before re-use.
- Use only accessories that are recommended by the manufacturer for use with your product. Accessories that may be suitable for one product may create a risk of injury when used with another tool. Never use an accessory that has a lower operating speed or operating pressure than the tool itself.

Specific Operation Warnings

⚠WARNING

- Maintain an adequate vertical down (tongue) load to maintain control of the trailer (generally 10%), but without exceeding the specified rated capacities.
- Other steps and inspections are also required Consult OSHA, D.O.T. regulations, and the American Trucking Association for complete coupling and uncoupling procedures.
- Check that ball load rating is same as or greater than coupler load rating.
- ALWAYS use safety chains.
- DO NOT use top holes for mounting.

Towing

⚠WARNING

- Use only with trailers and equipment designed for on-road towing within the stated capacities.

Installation Instructions

⚠WARNING

- Use a secure mounting structure of sufficient strength to support the rated capacity of the coupler in accordance with SAE J684.

Weld the coupler to the front of the trailer tongue. Care must be taken to get a good penetration without undercutting the coupler or the tongue. (See the illustration below for weld locations.)

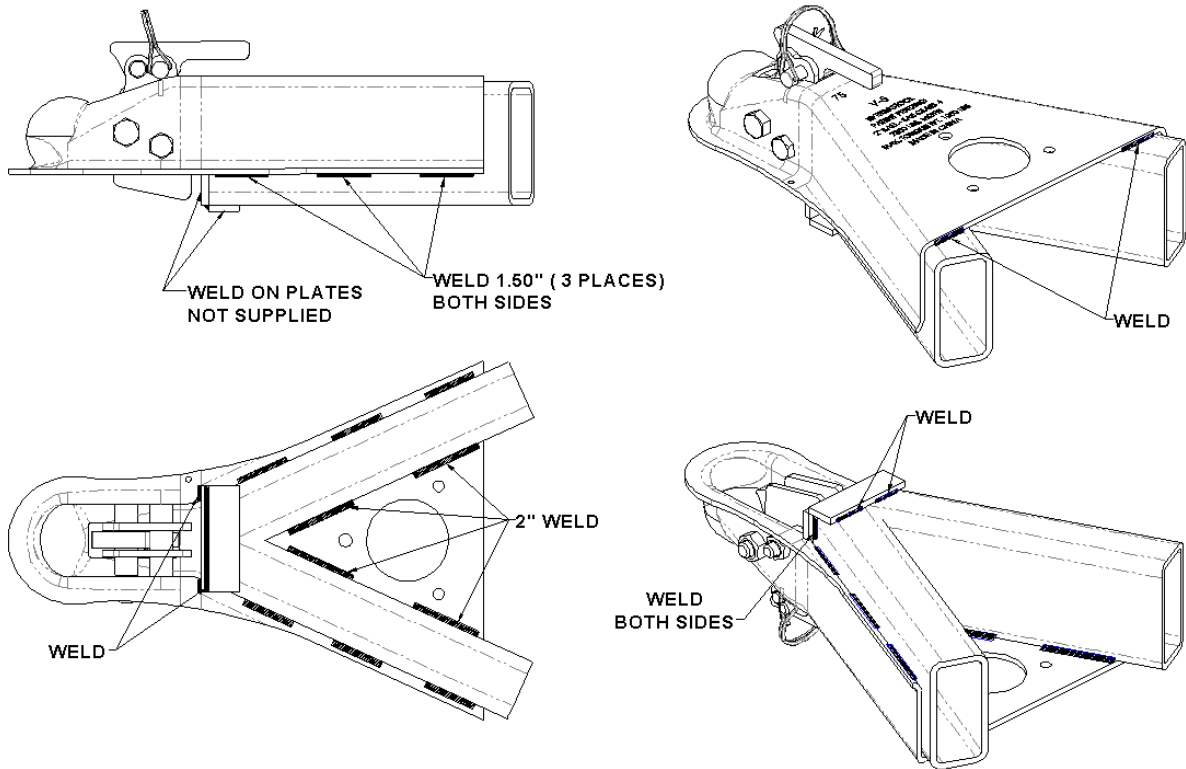

Before Each Use

⚠WARNING

- Inspect for proper operation.
- Inspect, in particular, the coupling area. Replace when the wear exceeds 1/8" (.125") from the original surface profile.
- Inspect for worn, damaged, and missing parts. Replace as required.

Operating Instructions

⚠WARNING

- It is the user's responsibility to be sure the hitch tongue is capable of a 750 lb. vertical load and a 5,000 lb. gross trailer weight.
- Every time the coupler is used, make sure the ball is completely engaged in the socket and the coupler is securely locked. Failure to do so could result in a serious or fatal injury.
- Safety chains must be used in a criss-cross manner under the coupling, allowing only enough slack for turns.
- Make sure all parked units are on a hard, level surface and all safety devices are engaged.
- Double check that lights are installed and working properly.

Auto Lock Function

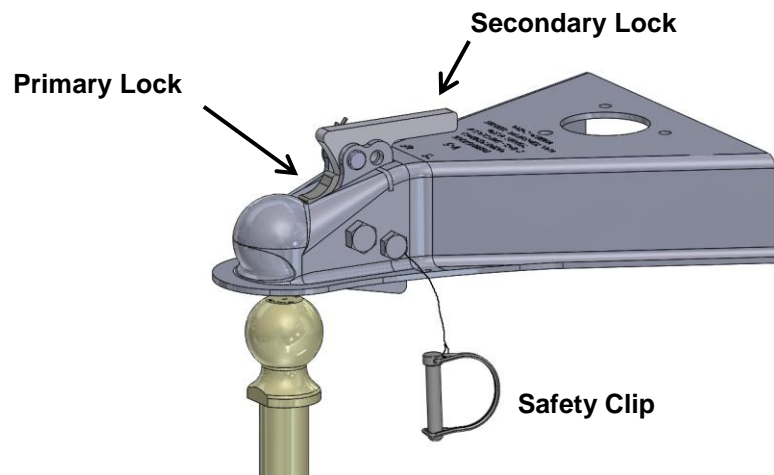

Unlocked Position

The illustration shown is in the unlocked position.
When the Primary Lock does not show green, the coupler is open.

Hitching Up

1. Before operating, inspect for proper operation and worn, damaged, or missing parts.
2. Unlock by removing the safety pin and insuring that the Primary Lock does not show green, indicating the coupler is open.
3. Back the vehicle up to the trailer until the 2" ball is located under trailer hitch (as shown above).
4. As you lower the trailer hitch onto the ball, the Primary Lock and the Secondary Lock will shift into the locked position, as shown.

Green = LOCKED

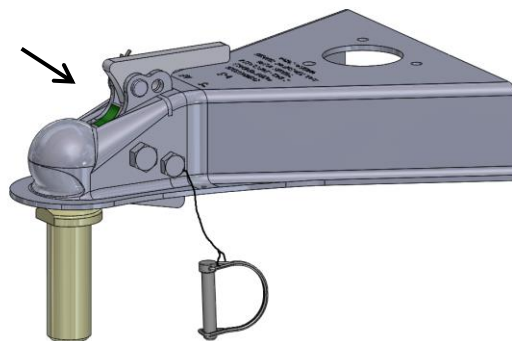

Locked Position

The illustration shown to the right is in the locked position,
with the Safety Clip installed. Insure lock assembly is in the
unlock position before hook-up.

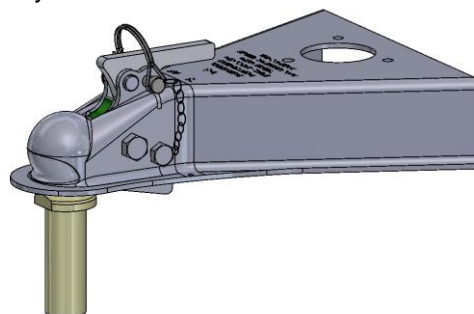

Un-Hitching

1. Unlock by removing the Safety Clip.
2. Flip the Secondary Lock forward until it is pointing up, hold while raising the jack.
3. If both hands are needed, the Secondary Lock can be held by inserting the Safety Clip into the top hole while raising the jack.

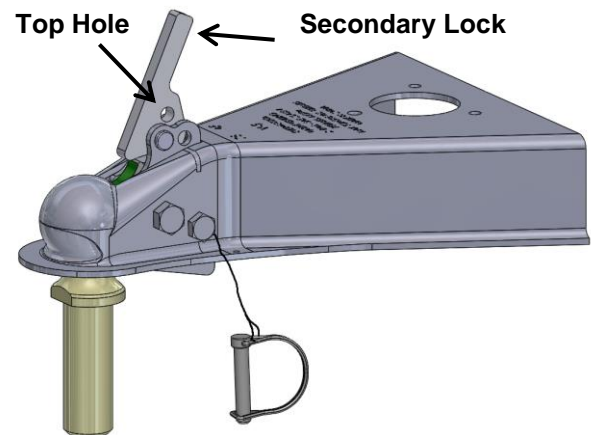

4. Jack up the trailer hitch until it clears the hitch ball. Pull out the Safety Clip. The unit is back to the unlocked position, as shown in the first illustration.

After Each Use

⚠WARNING

- Inspect for proper operation.
- Inspect, in particular, the coupling area. Replace when the wear exceeds 1/8" (.125") from the original surface profile.
- Inspect for worn, damaged, and missing parts. Replace as required.

Maintenance

⚠WARNING

- Inspect for proper operation.
- Inspect, in particular, the coupling area. Replace when the wear exceeds 1/8" (.125") from the original surface profile.
- Inspect for worn, damaged, and missing parts. Replace as required.

Maintain the coupler hitch by adopting a program of conscientious repair and maintenance in accordance with the following recommended procedures. It is recommended that the general condition of any tool be examined before it is used. Keep your tool in good repair. Keep handles dry, clean, and free from oil and grease. The following chart is based on a normal operation schedule.

Maintenance Interval	Maintenance Point
After the first 200 miles of towing.	Check the torque specification of the hitch ball and re-torque if necessary.
After every 400 miles of towing.	Check the torque specification of the hitch ball and re-torque if necessary.
The following should be performed every 10,000 miles or 6 months.	<ul style="list-style-type: none"> • Inspect for proper operation. • Inspect, in particular, the coupling area. Replace when the wear exceeds 1/8" (.125") from the original surface profile. • Inspect for worn, damaged, and missing parts. Replace as required. • Always use the safety clip.

Troubleshooting

Use the table below to troubleshoot problems before contacting service personnel or your local dealer. If the problem continues after troubleshooting, call your local dealer for assistance.

Failure	Possible Cause	Corrective Action
The coupler will not fit down over the hitch ball.	Debris is packed in the coupler.	Remove all debris from the coupler.
	The Primary Lock is not in the correct position.	Before connecting, make sure the Primary Lock does not show green; green means locked.
The coupler will not release the hitch ball.	The Secondary Lock is in the locked position.	Flip up the Secondary Lock and jack up the trailer.

Parts Diagram

HIT/HITCH
HM12

- 750 lbs. (340 kg) Max. Vertical Load.
 - 5,000 lbs. (2,270 kg) Max. Gross Trailer Weight.
 - Formed Steel body for strength and durability.
 - Supplied with a tethered lock pin.

All dimensions shown are nominal

ITEM NO.	PART OR IDENTIFYING NO.	NOMENCLATURE OR DESCRIPTION	MATERIAL SPECIFICATION	QTY REQD
14	HM121	Ø3/8" SAFETY CLIP, Cable/Chain	STEEL	1
13	MI-29	Ø 1/8" x 1" LG COTTER PIN	STEEL	1
12	WA60	Ø3/8" STANDARD FLAT WASHER	STEEL	1
11	SP3500-1	SHORT SPACER	STEEL	3
10	SP3500	LONG SPACER	STEEL	1
9	HM22	Ø3/8" x 1.25" LG. CLEVIS PIN	STEEL	1
8		M12 - 1.75 x 75mm Lg Cap Screw	Gr. 8.8	1
7		M12 - 1.75 STEEL LOCKNUT	Gr. 8.8	1
6		M10 - 1.5 x 75mm Lg Cap Screw	Gr. 8.8	1
5		M10 - 1.5 STEEL LOCKNUT	Gr. 8.8	1
4	SL3500J	Secondary Lock	STEEL	1
3	PL3500J	Primary Lock	STEEL	1
2	TGB3500J	Trailer Guide Bracket	STEEL	1
1	F20050	2" Ball, A-Frame CLASS 3 coupler	STEEL	1

- Steel
- Painted Black

NAME	DATE	POWER PIN INC.
DRAWN: LW	NOV 1/16	
DESCRIPTION: TRAILER BALL HITCH ASSEMBLY 2" BALL, A-FRAME COUPLER 5,000 LBS. MGTW		
PART NO. CA20050		REV 0
www.powerpin.ca		

PROPRIETARY AND CONFIDENTIAL
 THE INFORMATION CONTAINED IN THIS DRAWING IS THE SOLE PROPERTY OF POWER PIN INC. ANY REPRODUCTION IN PART OR AS A WHOLE WITHOUT THE WRITTEN PERMISSION OF POWER PIN INC. IS PROHIBITED.

Parts List

Reference	Part Number	Item Description	Quantity
1	F20050	2" Ball, A-Frame Class 3 Coupler	1
2	TGB3500J	Trailer Guide Bracket	1
3	PL3500J	Primary Lock	1
4	SL3500J	Secondary Lock	1
5		M10 – 1.5 Steel Locknut	1
6		M10 -1.5 x 75mm Cap Screw	1
7		M12 – 1.75 Steel Locknut	1
8		M12 -1.75 x 75mm Cap Screw	1
9	HM22	3/8" x 1.25" Large Clevis Pin	1
10	SP3500	Long Spacer	1

Reference	Part Number	Item Description	Quantity
11	SP3500-1	Short Spacer	3
12	WA60	3/8" Standard Flat Washer	1
13	MI-29	1/8" x 1.0" Large Cotter Pin	1
14	HM121	3/8" Safety Clip with Chain/Cable	1

Replacement Parts

- For replacement parts and technical questions, please call Customer Service at **1-800-222-5381**.
- Not all product components are available for replacement. The illustrations provided are a convenient reference to the location and position of parts in the assembly sequence.
- When ordering parts, the following information will be required: item description, item model number, item serial number/item lot date code, and the replacement part reference number.
- The distributor reserves the rights to make design changes and improvements to product lines and manuals without notice.

Limited Warranty

Northern Tool and Equipment Company, Inc. ("We" or "Us") warrants to the original purchaser only ("You" or "Your") that the Ultra-Tow product purchased will be free from material defects in both materials and workmanship, normal wear and tear excepted, for a period of **three years** from date of purchase. The foregoing warranty is valid only if the installation and use of the product is strictly in accordance with product instructions. There are no other warranties, express or implied, including the warranty of merchantability or fitness for a particular purpose. If the product does not comply with this limited warranty, Your sole and exclusive remedy is that We will, at our sole option and within a commercially reasonable time, either replace the product or product component without charge to You or refund the purchase price (less shipping). This limited warranty is not transferable.

Limitations on the Warranty

This limited warranty does not cover: (a) normal wear and tear; (b) damage through abuse, neglect, misuse, or as a result of any accident or in any other manner; (c) damage from misapplication, overloading, or improper installation; (d) improper maintenance and repair; and (e) product alteration in any manner by anyone other than Us, with the sole exception of alterations made pursuant to product instructions and in a workmanlike manner.

Obligations of Purchaser

You must retain Your product purchase receipt to verify date of purchase and that You are the original purchaser. To make a warranty claim, contact Us at 1-800-222-5381, identify the product by make and model number, and follow the claim instructions that will be provided. The product and the purchase receipt must be provided to Us in order to process Your warranty claim. Any returned product that is replaced or refunded by Us becomes our property. You will be responsible for return shipping costs or costs related to Your return visit to a retail store.

Remedy Limits

Product replacement or a refund of the purchase price is Your sole remedy under this limited warranty or any other warranty related to the product. We shall not be liable for: service or labor charges or damage to Your property incurred in removing or replacing the product; any damages, including, without limitation, damages to tangible personal property or personal injury, related to Your improper use, installation, or maintenance of the product or product component; or any indirect, incidental or consequential damages of any kind for any reason.

Assumption of Risk

You acknowledge and agree that any use of the product for any purpose other than the specified use(s) stated in the product instructions is at Your own risk.

Governing Law

This limited warranty gives You specific legal rights, and You also may have other rights which vary from state to state. Some states do not allow limitations or exclusions on implied warranties or incidental or consequential damages, so the above limitations may not apply to You. This limited warranty is governed by the laws of the State of Minnesota, without regard to rules pertaining to conflicts of law. The state courts located in Dakota County, Minnesota shall have exclusive jurisdiction for any disputes relating to this warranty.

ULTRA-TOW™ **XTP SERIES**

Distributed by:

Northern Tool & Equipment Company, Inc.

Burnsville, Minnesota 55306

www.northerntool.com

Made in China