

## Installation Guide

### JD 7R/8R-8RT/9R-9RX KM 1310 Air Seat Kit (PN: 6991)

1. Remove the command arm console from the original seat. Keep the mounting hardware for later use.
2. Remove the original seat and suspension. Keep the mounting hardware for later use.
3. If the original seat was an Active Seat, plug the hydraulic lines using the plugs provided.
4. Fasten the 6077 plate to the bottom of the suspension using four 5/16" x 3/4" flat head socket cap screws and flange nuts.
5. Remove the right hand armrest from the new seat.
6. Remove the seat top from the new suspension. Go to this link (<https://bit.ly/2AJfthi>) for a video on how to remove it.

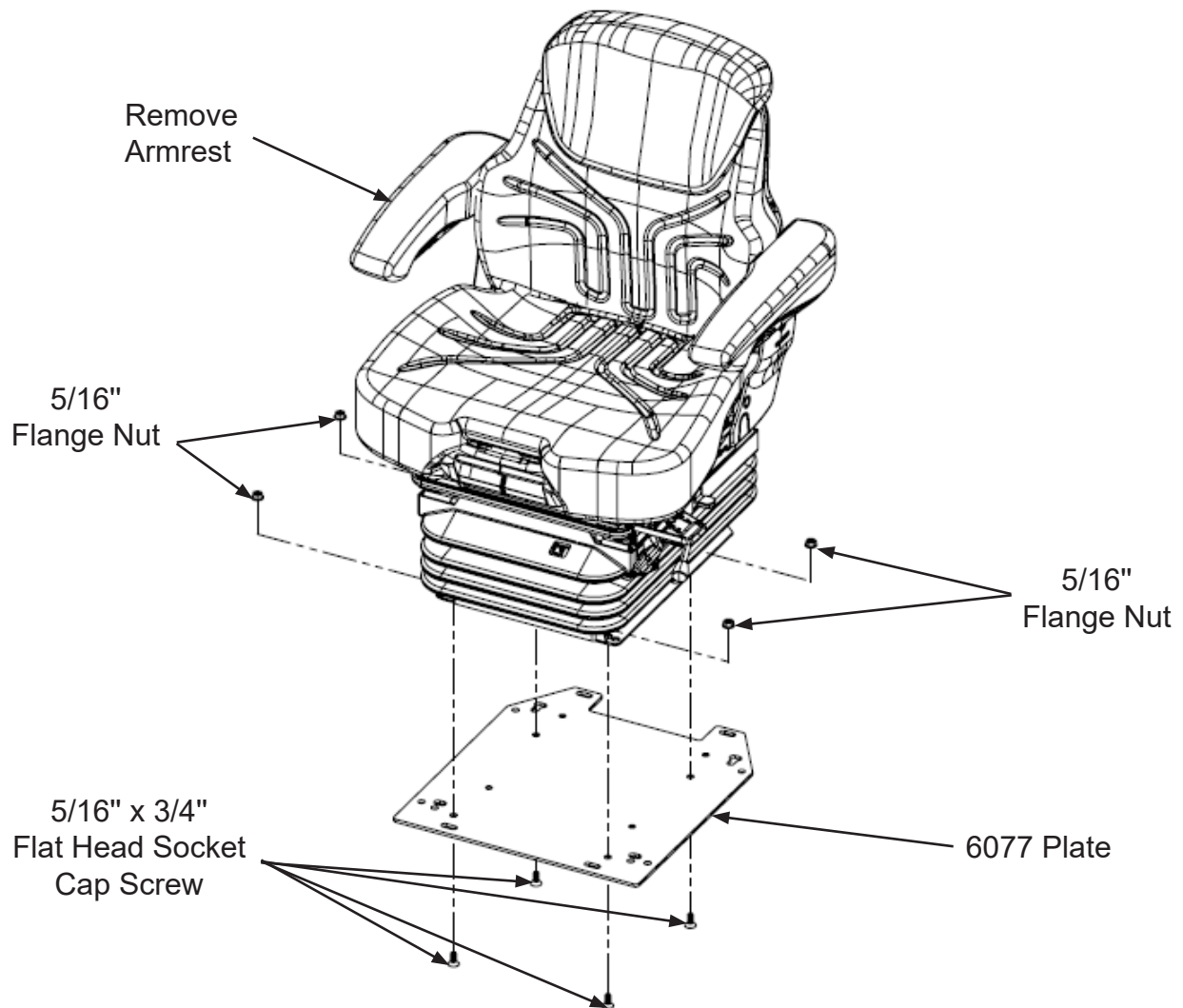

## Installation Guide

### JD 7R/8R-8RT/9R-9RX KM 1310 Air Seat Kit (PN: 6991)

7. Rotate the swivel 45 degrees as shown.
  8. Remove the plastic knock outs from the swivel on both halves (6 total). See diagram below for more clarity. The arrows point to the knockouts that need to be removed.
  9. Remove the two flat head socket cap screws and nuts holding the spacer bar to the swivel. Discard the hardware, but keep the spacer bar as it will be used later.
  10. Use three 5/16" washers as spacers to level the swivel on the slide rails. Install one on the second from the front hole on the right slide rail and one each on the rear holes of each slide rail.
  11. Remove the plastic knock outs from the swivel on both halves (6 total). See diagram below for more clarity. The arrows point to the knock outs.
  12. Place the swivel on top of the slide rails and fasten down with four 5/16" x 3/4" button head socket caps screws and four 5/16" center lock nuts.
- NOTE:** You will have to adjust the slide rails forward and backwards to get the nuts on.

Locations to Remove Knockouts

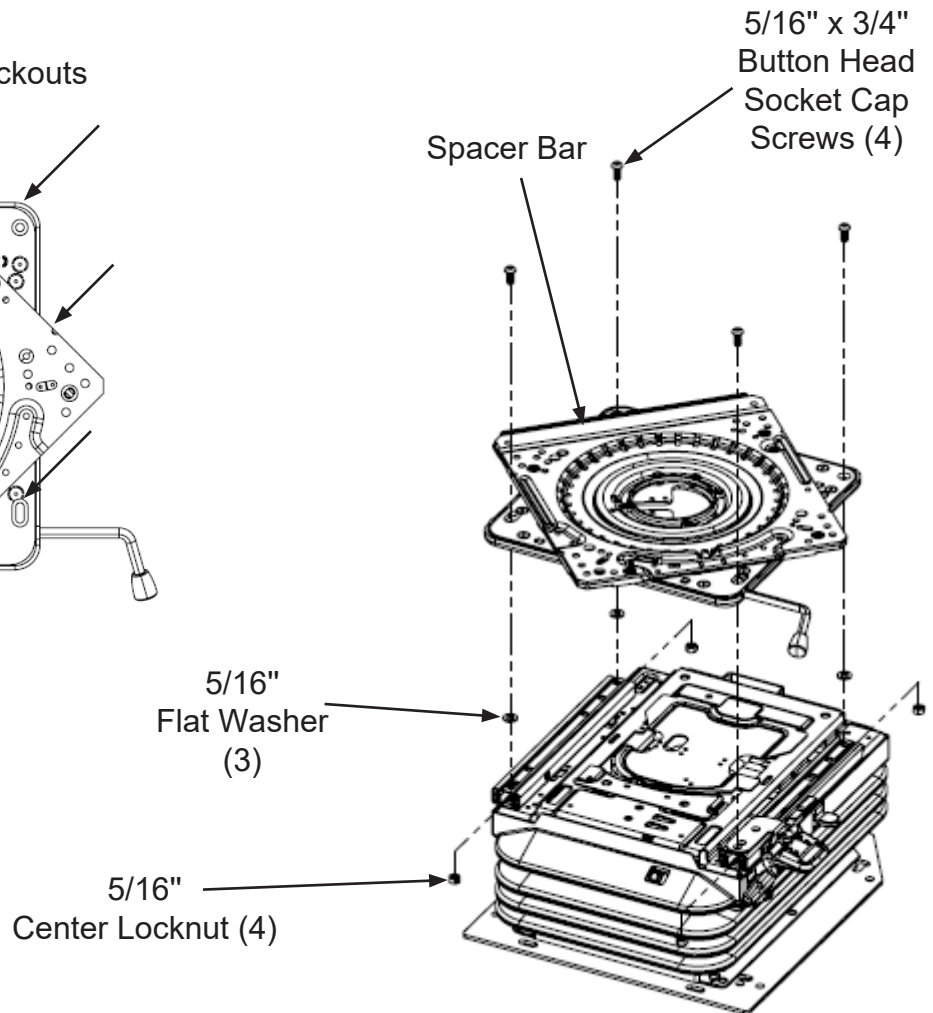
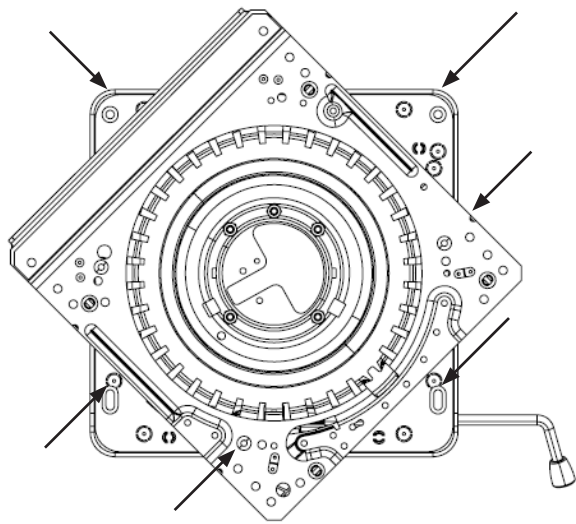

## Installation Guide

### JD 7R/8R-8RT/9R-9RX KM 1310 Air Seat Kit (PN: 6991)

13. Install the suspension assembly into the cab. Fasten down using the original hardware.
14. Attach the seat top and the command arm mount plate to the swivel using two 5/16" x 3/4" button head socket cap screws and flange nuts in the front two holes and two 5/16" x 1" flat head socket cap screws and flange nuts in the rear two holes. Be sure the spacer bar is in place on the swivel. You will have to rotate the swivels to get bolts in.
15. Reinstall the seat cushion and components in the reverse order they were removed.

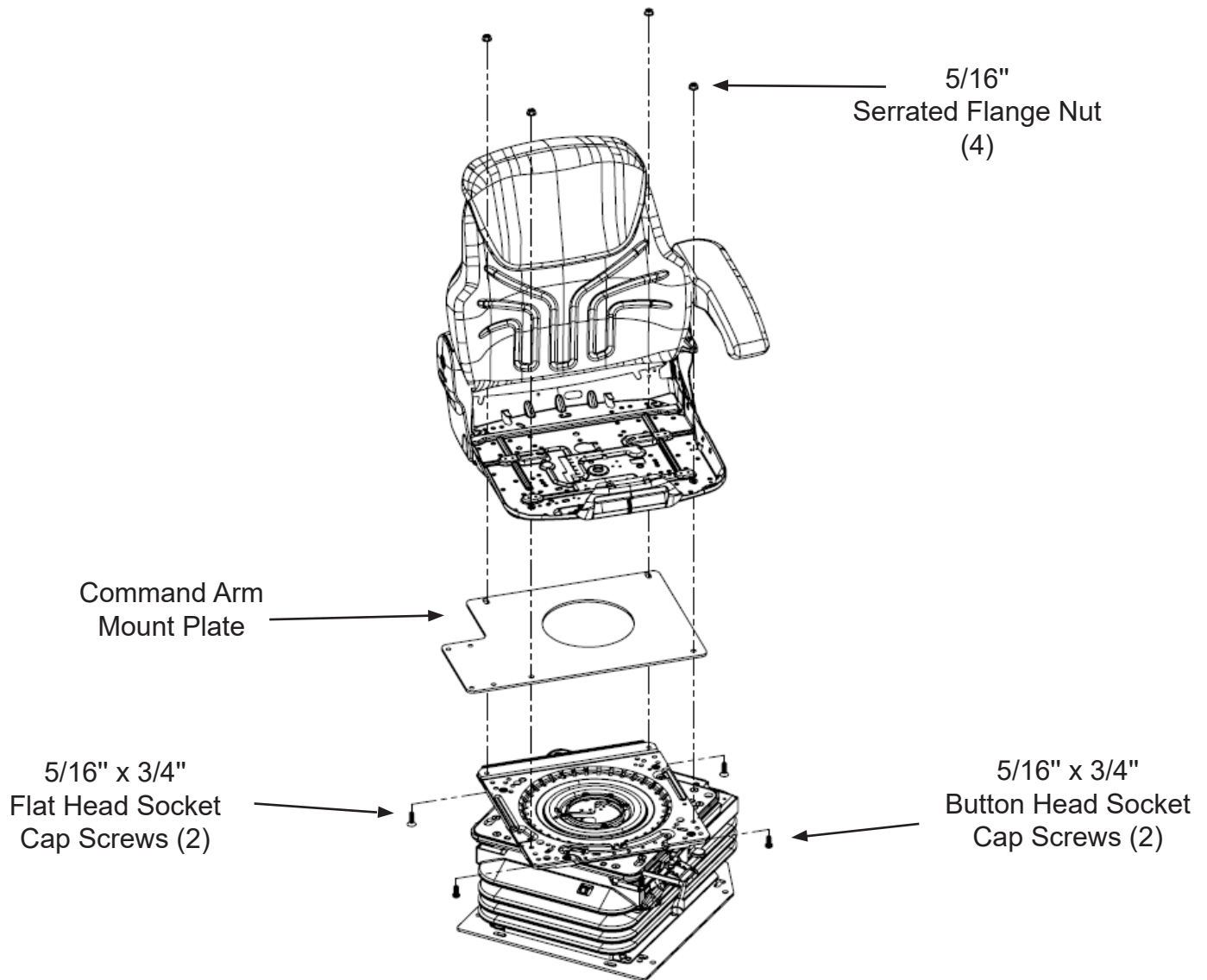

## Installation Guide

### JD 7R/8R-8RT/9R-9RX KM 1310 Air Seat Kit (PN: 6991)

- Reference the images below to determine which Command Arm mount you will need. The two Command Arm mounts on the left are of the JD OEM brackets.
- If your original Command Arm bracket is RE269958, use the Command Arm bracket XXXX. Command Arm bracket XXXX has a small half moon cutout to differentiate it from bracket XL. If your original is RE576471, use Command Arm bracket XXXX.
- Mount the Command Arm bracket to the Command Arm mount plate using four 5/16" x 3/4" carriage bolts and flange nuts.
- Reinstall the Command Arm console using the original hardware removed in step 1.
- Connect the seat wiring using the harnesses provided in the kit.

