

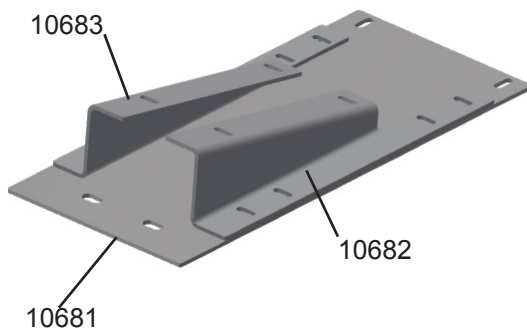

PN 8014



PN 8080



Instructions for installing an 8014 seat and 8080 suspension in a White tractor with either an original Grammer or Bostrom seat and suspension.

1. Remove the lower half of the slide rails from the new seat.
NOTE: One will slide out and the other can be removed by pulling the adjustment lever.
2. Install the lower slide rail halves to the suspension using the 8mm x 16mm bolts and lock washers included in the bolt bag. Keep the slide rail halves oriented the same way they came off the seat (the left lower half goes on the left of the suspension and the right lower half goes on the right of the suspension). Align the front of the slide rail halves with the front of the suspension.
3. Turn the suspension upside down. Loosen the rubber boot by pulling the rubber off the hooks.
4. Manually extend the suspension.
5. Attach brackets 10682 and 10683 using four 8mm x 16mm bolts, washers, lock washers and nuts. Insert the bolts in the holes marked on picture 1. NOTE: The bolts need to be run from inside the suspension outward washers, lock washers and nuts go on the bottom of plates 10682 and 10683.
6. Slide brackets 10682 and 10683 toward the center of the suspension as far as they will go and tighten hardware.
7. On the bottom of the new seat, loosen the Phillips head screws and slide the upper slide rail halves inward to the 7" center position.
Do not tighten.
8. Slide the seat and slide rails onto the suspension see picture 2 and tighten the Phillips screws on the bottom of the seat. Makes sure the seat slides fore and aft easily to ensure the two halves of the slide rails are aligned properly. To access the Phillips screws, slide the seat forward to tighten the front screws and backward to tighten the rear screws.



Picture 1



Picture 2

Instructions for installing an 8014 seat and 8080 suspension in a White tractor with either an original Grammer or Bostrom seat and suspension.

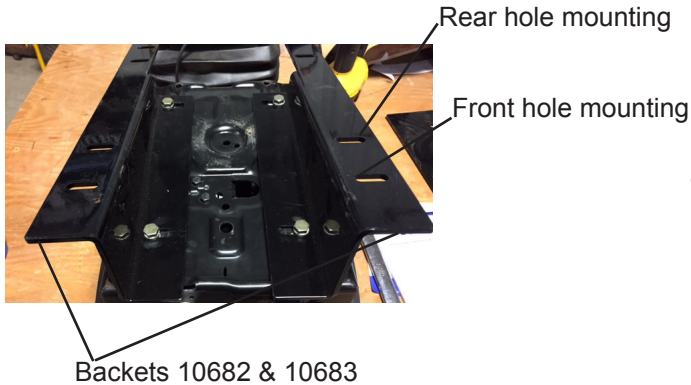

Weight adjustment

9. Remove your old seat from the tractor. Keep the mounting bolts for later use.
- 10a. For tractors that had an original Bostrom seat, lay plate 10681 onto the cab floor, align holes and replace the original bolts in the front holes and tighten.
NOTE: If the tractor had an original Grammer seat, skip to step 11.
- 10b. Set the seat assembly onto plate 10681. Either set of holes on the bottom of brackets 10682 and 10683 can be used depending on operator preference. One set of holes will locate the seat and suspension closer to the steering wheel and one set will move it further away.
11. For tractors with an original Grammer seat, install seat and suspension using the original bolts and washers. Either set of holes on the bottom of brackets 10682 and 10683 can be used depending on operator preference. One set of holes will locate the seat and suspension closer to the steering wheel and one set will move it further away.
12. For air suspensions, run a wire from a 12v source in the fuse box to the connector on the rear of the suspension. Also run a ground wire to the connector as well. Polarity does not matter on the air suspension connector.