

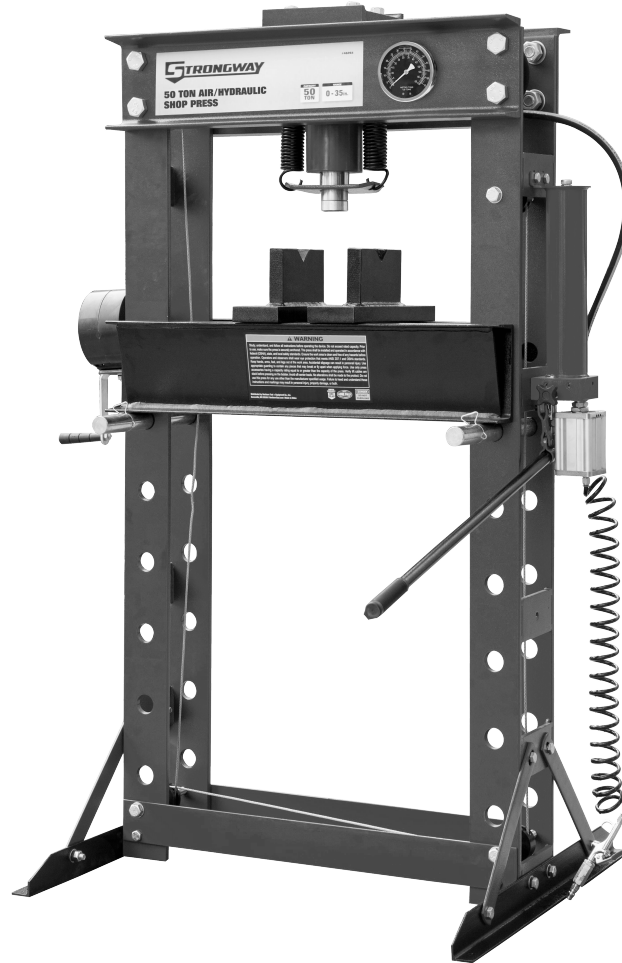

50 TON AIR/HYDRAULIC SHOP PRESS

OWNER'S MANUAL



WARNING:

Read carefully and understand all **ASSEMBLY AND OPERATION INSTRUCTIONS** before operating. Failure to follow the safety rules and other basic safety precautions may result in serious personal injury.

Item# 46264

Thank you very much for choosing a Strongway product! For future reference, please complete the owner's record below:

Model: _____ Purchase Date: _____

Save the receipt, warranty and these instructions. It is important that you read the entire manual to become familiar with this product before you begin using it.

This machine is designed for certain applications only. The distributor cannot be responsible for issues arising from modification. We strongly recommend this machine not be modified and/or used for any application other than that for which it was designed. If you have any questions relative to a particular application, DO NOT use the machine until you have first contacted the distributor to determine if it can or should be performed on the product.

For technical questions please call **1-800-222-5381**.

INTENDED USE

This Shop Press is designed for automotive, truck, implement, fleet, and industrial repair shops where pressing, bending, straightening and forming, is required. Typical applications include installation and removal of alternator and power steering pump bearings, axle bearings, transmission bearings, seals, u-joints and many other jobs.

TECHNICAL SPECIFICATIONS

	Description
Item	46264
Capacity	50 Ton
Working Press(PSI)	100-175
Air Inlet Size(in.ZG)	1/4
Work Range (in.)	0 to 35
Stroke Length(in.)	6 7/8
Inside Bed Dimensions L x W (in.)	27 1/8 x 6 7/8
Dimensions L x W x H	49 3/16 x 31 1/2 x 65 5/16
Foot Switch Included	No
Winch Included	YES

Safe Operating Temperature is between 40°F – 105°F (4°C - 41°C)

Ensure that the air source can dedicate 100-175 psi to each jack operated. A minimum of 110 psi air pressure is required to raise rated capacity load.

GENERAL SAFETY RULES



WARNING: Read and understand all instructions. Failure to follow all instructions listed below may result in serious injury.



CAUTION: Do not allow persons to operate or assemble this Shop Press until they have read this manual and have developed a thorough understanding of how the Shop Press works.



WARNING: The warnings, cautions, and instructions discussed in this instruction manual cannot cover all possible conditions or situations that could occur. It must be understood by the operator that common sense and caution are factors which cannot be built into this product, but must be supplied by the operator.

SAVE THESE INSTRUCTIONS

IMPORTANT SAFETY CONSIDERATIONS

SHOP PRESS USE AND CARE

- **Do not modify the Shop Press in any way.** Unauthorized modification may impair the function and/or safety and could affect the life of the equipment. There are specific applications for which the **Shop Press** was designed.
- **Always check of damaged or worn out parts before using the Shop Press.** Broken parts will affect the **Shop Press** operation. Replace or repair damaged or worn parts immediately.
- **Store idle Shop Press.** When **Shop Press** is not in use, secure it out of the reach of children. Inspect it for good working condition prior to storage and before re-use.
- **Not for use by children** or people with reduced mental capacity.
- **Do not use under the influence of drugs or alcohol.**
- **Ensure children and other bystanders** are kept at a safe distance when using press.

INSPECTION

- Inspect the press carefully before each use. Ensure the press is not damaged, excessively worn, or missing parts.
- Do not use the press unless it is properly lubricated.
- Using a press that is not in good clean working condition or properly lubricated may cause serious injury.
- Inspect the work area before each use. Make sure it is free and clear of any potential hazards.

DO NOT OPERATE OR REPAIR THIS EQUIPMENT WITHOUT READING THIS MANUAL.

To maintain the Shop Press and user safety, the responsibility of the owner is to read and follow these instructions. Inspect the service shop press for proper operation and function. Keep instructions readily available for equipment operators. Make certain all equipment operators are properly trained; understand how to safely and correctly operate the unit. Allow unit operation only with all parts in place and operating properly. Use only genuine replacement parts. Service and maintain the unit only with authorized or approved replacement parts negligence will make the shop press unsafe for use and void the warranty. Carefully inspect the unit on a regular basis and perform all maintenance as required. Store these instructions in the handle of your shop press. Keep all decals on the unit clean and visible.

SAFETY

Always follow safety precautions when installing and operating this shop press. Keep all decals on the unit clean and visible. Before proceeding that you fully understand and comprehend the full contents of this manual. Failure to operate this equipment as directed may cause injury or death. The distributor is not responsible for any damages or injury caused by improper use or neglect

SAFETY MARKINGS

WARNING:

1. Study, understand, and follow all instructions before operating the device.
2. Do not exceed rated capacity.
3. Prior to use, make sure the press is securely anchored.
4. The press shall be installed and operated in accordance with federal (OSHA), state, and local safety standards.
5. Ensure the work area is clean and free of any hazards before operation.
6. Operators and observers shall wear eye protection that meets ANSI Z87.1 and OSHA standards.
7. Keep hands, arms, feet, and legs out of the work area. Accidental slippage can result in personal injury.
8. Use appropriate guarding to contain any pieces that may break or fly apart when applying force.
9. Use only press accessories having a capacity rating equal to or greater than the capacity of the press.
10. Verify lift cables are slack before pressing on the bolster.
11. Avoid off-center loads.
12. No alterations shall be made to the product.
13. Do not use this press for any use other than the manufacturer specified usage.
14. Failure to heed and understand these instructions and markings may result in personal injury, property damage, or both.



GENERAL SAFETY INSTRUCTIONS

PLEASE READ THESE INSTRUCTIONS CAREFULLY. NOTE THE SAFETY INSTRUCTIONS AND WARNING. USE THE PRODUCT CORRECTLY AND WITH CARE FOR THE PURPOSE OF WHICH IT IS INTENDED. FAILURE TO DO SO MAY CAUSE DAMAGE TO PROPERTY AND/OR SERIOUS PERSONAL INJURY. PLEASE KEEP THIS INSTRUCTION MANUAL SAFE FOR FUTURE USE.

We've done all we can to assure this press offers the utmost in safety, but you have to do your part. No amount of warning can take the place of your good judgment, so make sure it's the first thing you bring to any job. Beyond that here are some obvious tips:

- Steel and other materials can shatter, so always use protective eye-wear that complies with the appropriate ANSI code.
- If you detect anything that may indicate imminent structural failure, stop using the press immediately and inspect it thoroughly.
- Bolt the press to the floor if it is to be used on bulky or unstable items.
- Do not use press to compress springs or any other item that could disengage and cause a potential flying hazard.
- Use this press for the purpose for which it is intended. Do not use it for any other purpose it is not designed to perform.
- Keep children and unauthorized persons away from the work area.
- Remove loose fitting clothing. Remove ties, watches, rings and other loose jewelry and contain long hair.
- Wear ANSI approved impact safety goggles, full-face impact safety shield and heavy-duty work gloves when operating the press.
- Keep proper balance and footing, do not over-reach and wear nonskid footwear.
- Only use this press on a surface that is stable, level, dry and not slippery, and capable of sustaining the load. Keep the surface clean, tidy and free from unrelated materials and ensure that there is adequate lighting.
- Inspect the press before each use. Do not use if bent, broke, cracked, leaking or otherwise damaged. Any suspect parts are noted or it has been subjected to a shock load.
- Check to ensure that all applicable bolts and nuts are firmly tightened.
- Ensure that work piece is center-loaded and secure.
- Keep hands and feet away from bed area at all times.
- Do not use the shop press to compress spring or any other item that could disengage and cause a potential hazard. Never stand directly in front of loaded press and never leave loaded press unattended.
- Do not operate the press when you are tired or under the influence of alcohol, drugs or an intoxicating medication.
- Do not allow untrained persons to operate the press.
- Do not make any modifications to the press.
- Do not use brake fluid or any other improper fluid and avoid mixing different types of oil when adding hydraulic oil. Only good quality hydraulic jack oil can be used.
- Do not expose the press to rain or any other kind of bad weather.
- If the press needs repairing and/or there are any parts that need to be replaced, have it repaired by authorized technicians and only use the replacement parts supplied by the manufacturer.

ASSEMBLY

All numbers in parenthesis () refer to the index number from the parts breakdown.

1. Attach the two base support sections (21) and the cross member runner rails (62) to the frame (48) with bolt (16), washer (17), spring washer (18) and nuts (19).

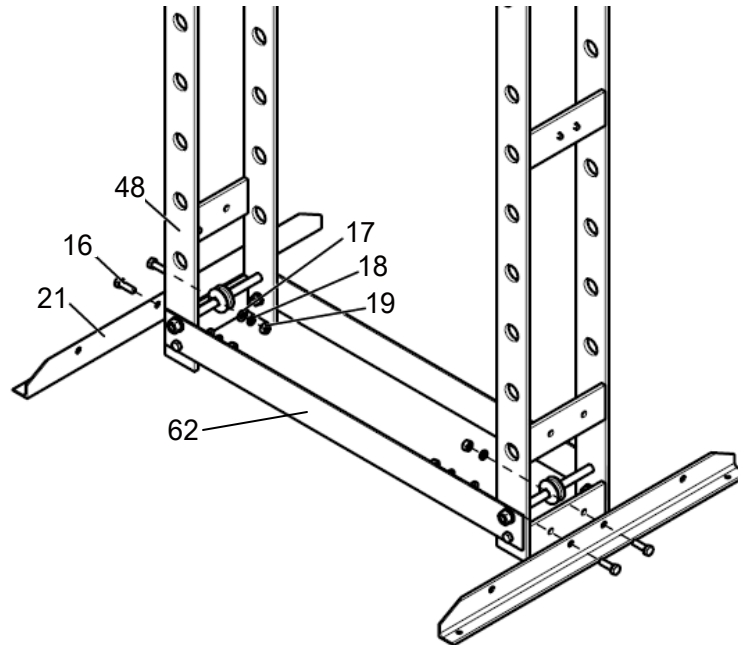

2. Attach side support rails (20) to base support sections (21) and frame (48) with bolt (16), washer (17), spring washer (18) and nuts (19).

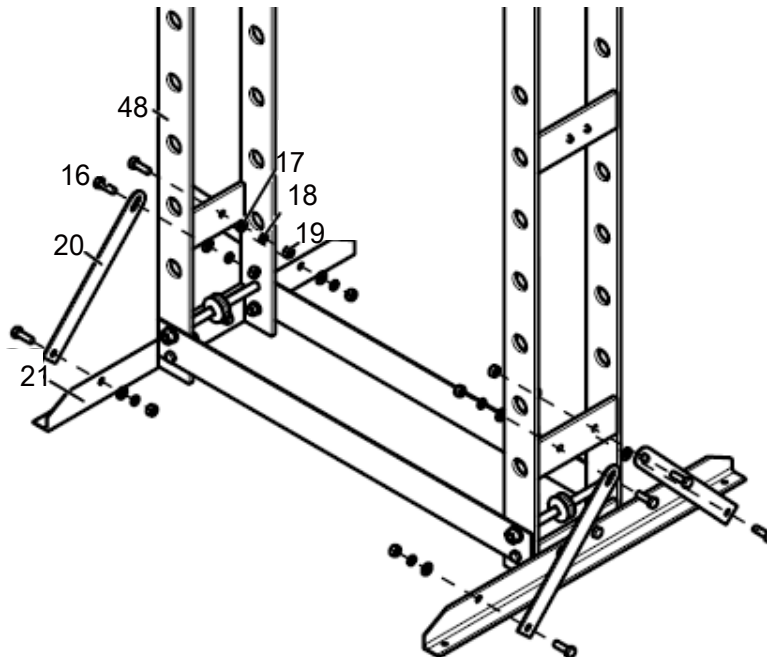

3. Attach the hydraulic air pump (13) to the right frame (61) with washer (10) spring washer (11) and bolt (9). Ensure that the hydraulic air pump (13) is securely installed.

Note: DO NOT drop hydraulic air pump during installation. Pump could be damaged if dropped or unsecured! Check that pump is secure before releasing your hold of the hydraulic air pump.

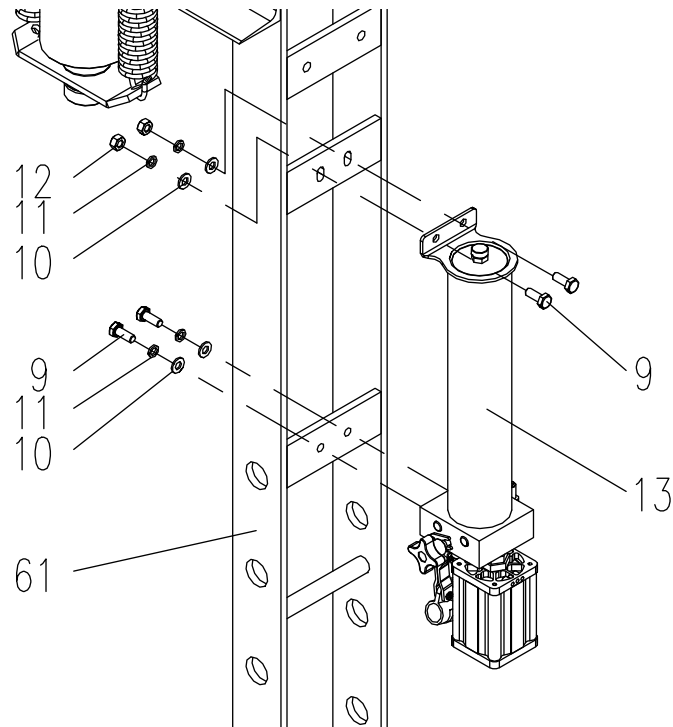

4. Locate the hydraulic hose connection points on for cylinder and hydraulic air pump. Then Connect the hydraulic hose to ram (58), then connect the hose fitting (29) to the hydraulic air pump.

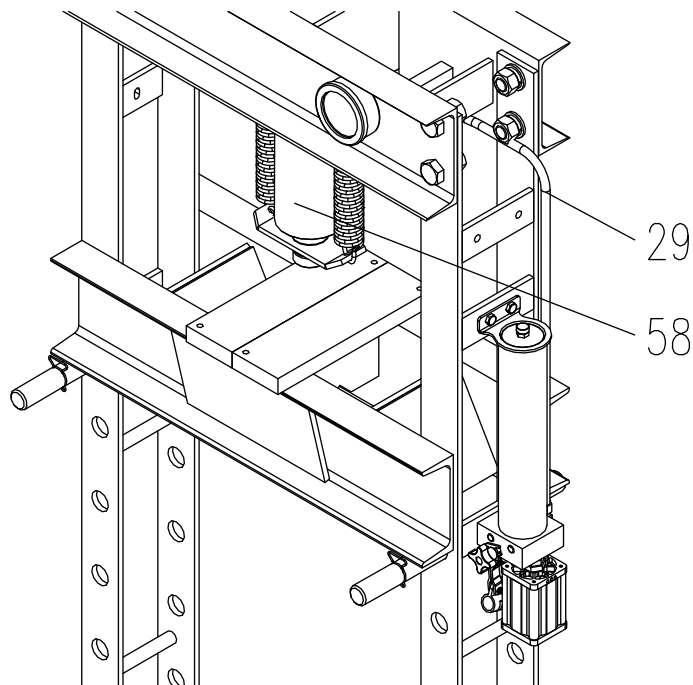

5. Attach the L-bracket (45) to the left frame (48) with spring washer (51), washer (50), bolt (49) and nut (52).
6. Then install winch (44) to the L-bracket (45) with spring washer (51), washer (50), bolt (49) and nut (52).

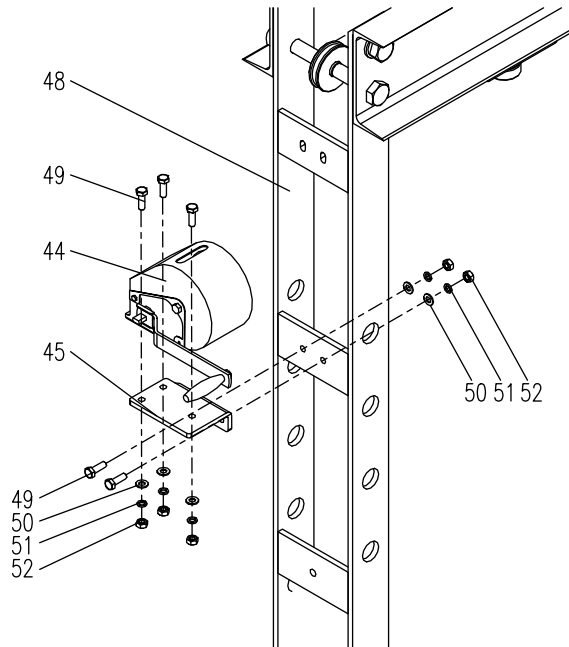

7. Rotating the winch handle into the down position.
8. Raise the joined press bed frame (60) to the desired height and insert the bed frame pins (46) into the holes on the frames (48). Secure the pins (46) with spring clips (47)

⚠ CAUTION: Press bed frame is heavy and could cause a potential hazard. Raise press bed frame with 2 or more people.

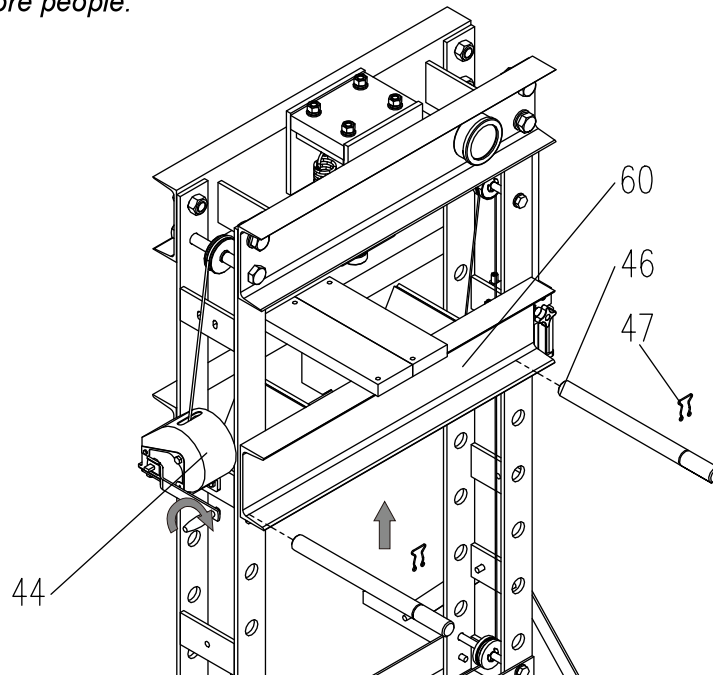

9. Place the bolster plates (59) on bed frame (60).

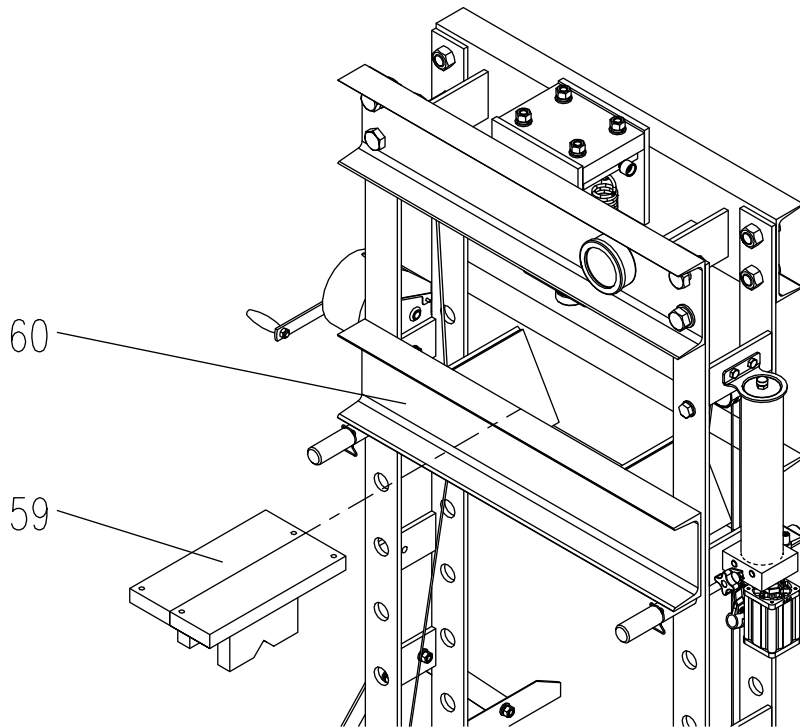

10. Insert the handle (14) into handle sleeve of the hydraulic pressure pump (13). Check for proper pump action.

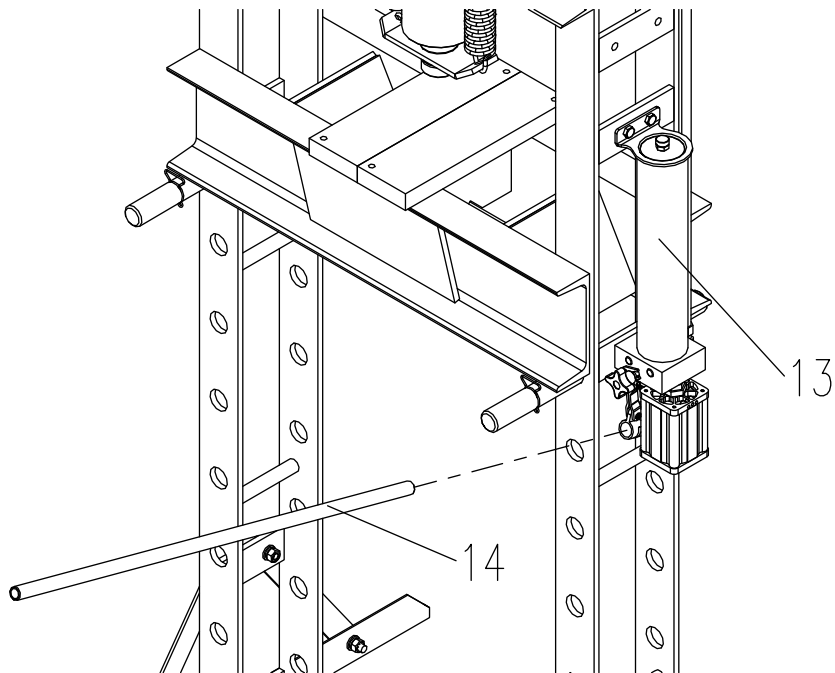

15. Verify that all bolts and screws have been tightened.

16. The press is now ready for use.

SYSTEM AIR PURGE PROCEDURE

IMPORTANT: BEFORE FIRST USE

All numbers in parenthesis () refer to the index number from the parts breakdown.

Perform the following Air Purge Procedure to remove any air that may have been introduced into the hydraulic system as a result of product shipment and handling. This step is to be completed without and weight on the jack.

1. Firmly close the Release Valve by turning it clockwise.

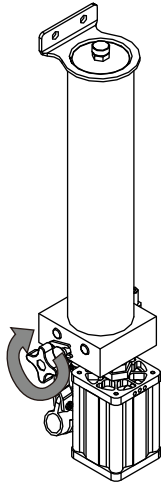

3. Continue pumping until the hydraulic fluid starts to come out from the end of the coupler tip and is free of air bubbles.

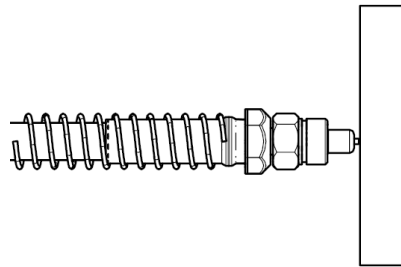

4. Check the oil level and add oil if necessary. (See instructions how to add oil.)
5. Turn the Release Valve counterclockwise to release the pressure in the pump and hose.

2. Remove the hydraulic cylinder end of the hydraulic hose and press the tip of the Coupling against a hard surface and pump the pump handle.

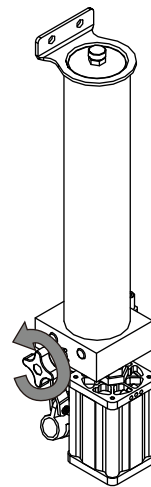
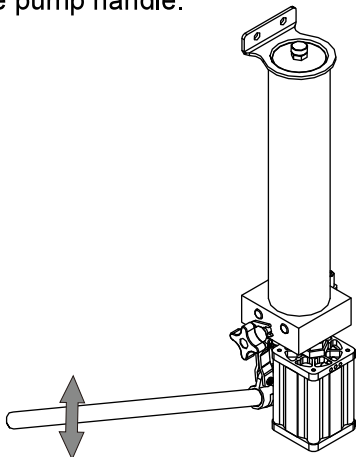

BEFORE USE

1. Before using this product, read the owner's manual completely and familiarize yourself thoroughly with the product and the hazards associated with its improper use.
2. Perform the air purge procedure. (See previous instructions for system purge procedure.)
3. Inspect before each use. Do not use if bent, broken or cracked components are noted.

OPERATION

All numbers in parenthesis () refer to the index number from the parts breakdown.

1. Insert the bed frame pins (46) to desired height, then lower the bed frame (60). Ensure bed frame is fully rested on the bed frame pins.

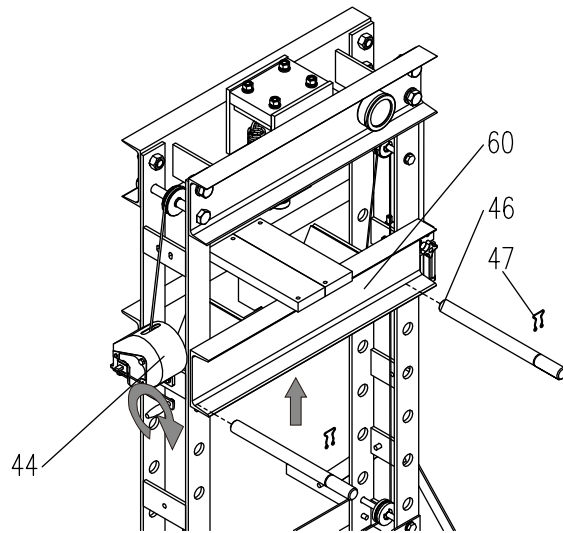

2. Place bolster plates on press bed frame (59).

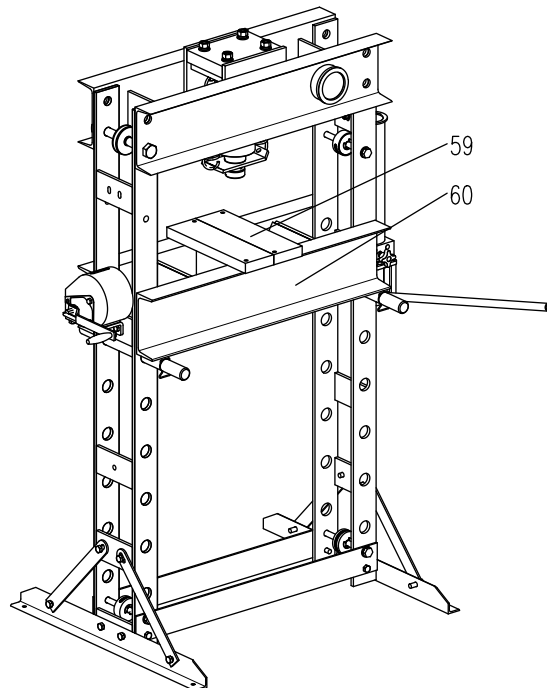

3. Place work piece on the bed frame or pressing block, use every precaution necessary to ensure safety and to prevent accidents. Position work piece in a manner which will not allow it to inadvertently fall from the bed frame or pressing block.

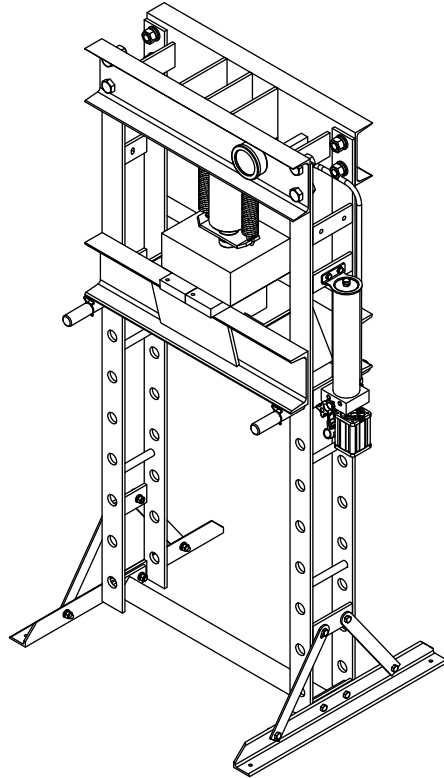

4. Close the release valve by turning it clockwise until it is firmly closed.

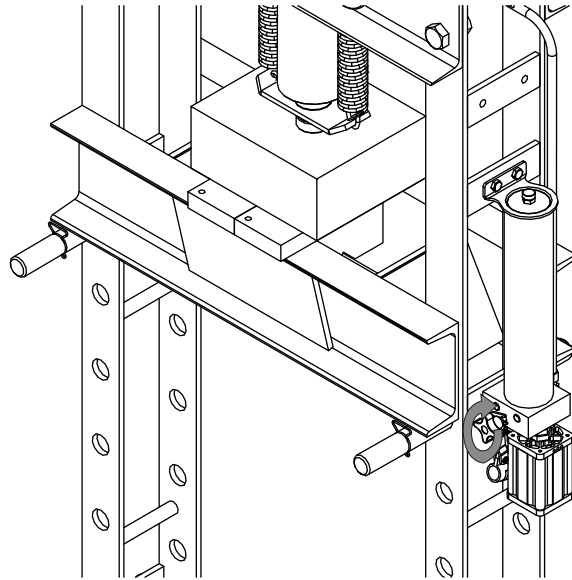

5. Connect the air hose inlet fitting onto the shop air supply hose lock fitting, pump air into the system until the ram nears the work piece. Then release the trigger when pumping needs to stop. **OR** When an air source is unavailable, pump the handle until the ram nears the work piece.

6. Align ram and work piece to ensure center-loading. Do not overload work piece.

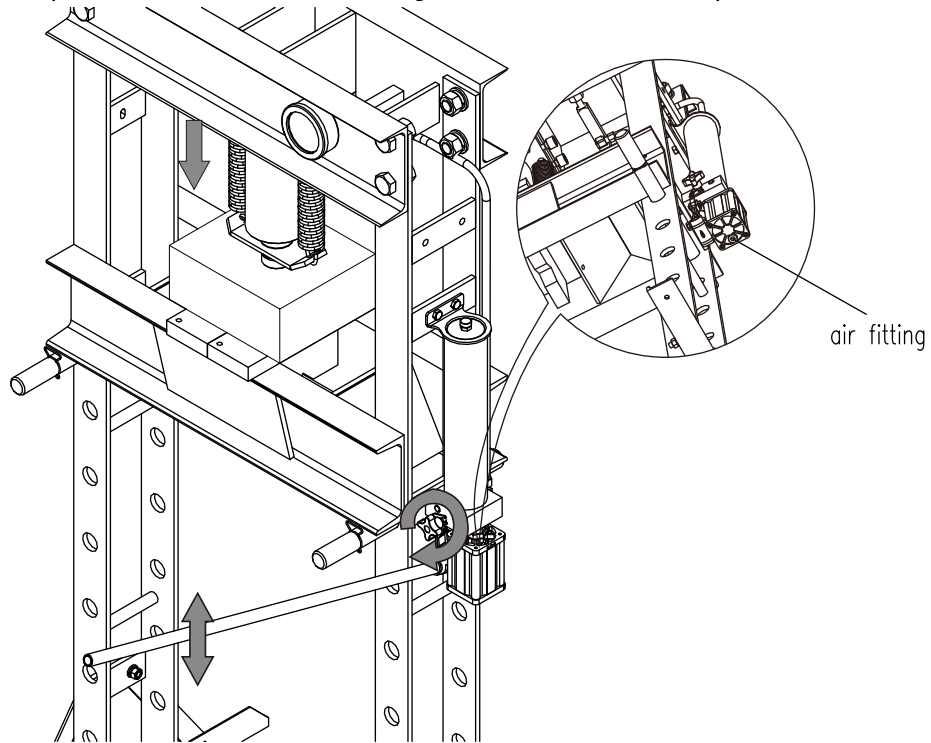

7. When work is completed, stop pumping the handle (or release the trigger). Slowly turn the release valve counter-clockwise in small increments until ram is free from work piece.
8. Once ram has fully retracted, remove workplace from bed frame.
Cautiously remove work piece from press.

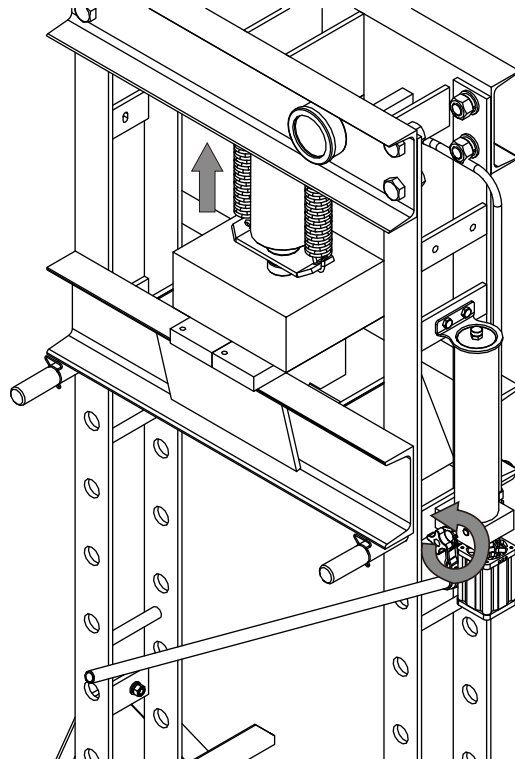

MAINTENANCE INSTRUCTIONS

If you use and maintain your equipment properly, it will give you many years of service. Follow the maintenance instructions carefully to keep your equipment in good working condition. Never perform any maintenance on the equipment while it is under a load.

Inspection

You should inspect the product for damage, wear, broken or missing parts (e.g.: pins) and that all components function before each use. Follow lubrication and storage instructions for optimum product performance.

Binding

If the product binds while under a load, use equipment with equal or a larger load capacity to lower the load safely to the ground. After un-binding; clean, lubricate and test that equipment is working properly. Rusty components, dirt, or worn parts can be causes of binding Clean and lubricate the equipment as indicated in the lubrication section. Test the equipment by lifting without a load. If the binding continues contact Customer Service.

Cleaning

If the moving parts of the equipment are obstructed, use cleaning solvent or another good degreaser to clean the equipment. Remove any existing rust, with a penetrating lubricant.

Lubrication

This equipment will not operate safely without proper lubrication. Using the equipment without proper lubrication will result in poor performance and damage to the equipment. Some parts in this equipment are not self-lubricating inspect the equipment before use and lubricate when necessary. After cleaning, lubricate the equipment using a high grade light penetrating oil or lubricating spray.

-For light duty use lubrication once a month.

-For heavy and constant use lubrication recommended every week.

-NEVER USE SANDPAPER OR ABRASIVE MATERIAL ON THESE SURFACES!

Rust Prevention:

-Check rams and pump plungers on the power unit assemblies daily for any signs of rust or corrosion.

Without a load on the equipment extended hydraulic rams to check if signs of rust are visible clean as needed.

How the Ram Operates

With release valve closed, an upward stroke of the handle draws oil from the reservoir tank into the plunger cavity. Hydraulic pressure holds the valve closed, which keeps the oil in the plunger cavity. A downward stroke of the handle releases oil into the cylinder, which forces the ram out. This extends the ram. When the ram reaches maximum extension, oil is bypassed back into the reservoir to prevent an over extended ram stroke and possible damage to the ram. Opening the release valve allows oil to flow back into reservoir. This releases hydraulic pressure on the ram, which results in lowering the ram.

Storing the Ram

1. Fully Retract Ram after use.
2. Place the handle in the upright position.
3. Store in a dry location, recommended indoors.

Note: If the press is stored outdoors, be sure to lubricate all parts before and after use to ensure the press stays in good working condition.

TO ADD OIL:

The hydraulic cylinder assembly contains hydraulic fluid that must be kept at approximately 80% full at all times for proper operation. To check the oil level and to fill remove oil filler plug

1. Fully retract the hydraulic ram.
2. Remove the oil plug.

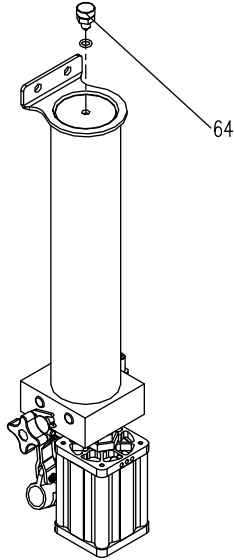

4. Replace the oil plug.

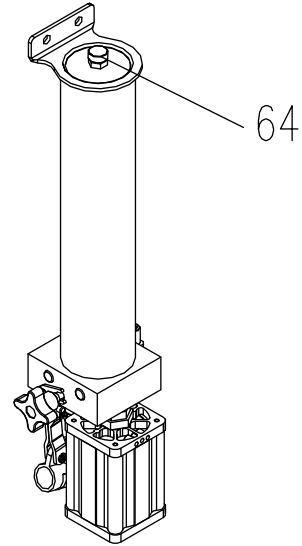

3. Fill the oil case until oil level is just beneath the lower rim.

KEEP DIRT AND OTHER MATERIAL CLEAR WHEN POURING.

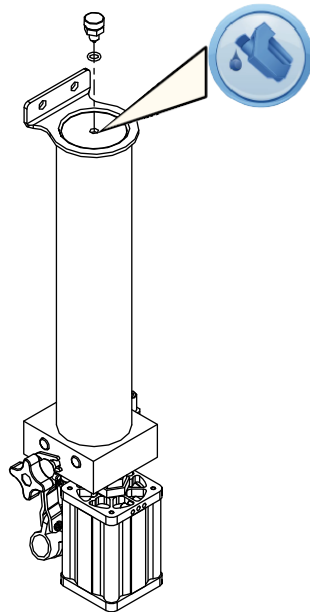

5. Perform the Air Purge Procedure.

To Replace Oil:

1. Position the pump in the vertical position and fully retract the hydraulic ram.
2. Open release valve by turning handle counter-clockwise (4 full turns).

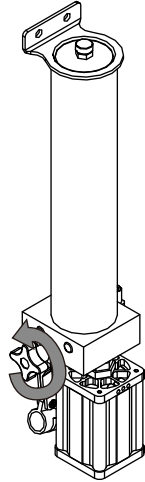

5. Fill the oil case until oil level is just beneath the lower rim.
KEEP DIRT AND OTHER MATERIAL CLEAR WHEN POURING.

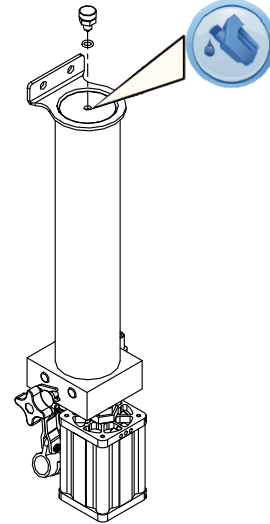

3. Remove the oil plug.

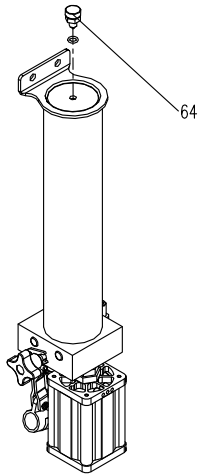

6. Replace the oil plug.

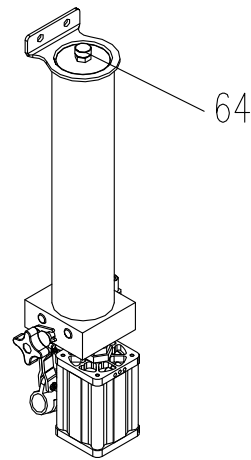

4. Turn the pump on its side so that old oil will drain from the oil fill hole.

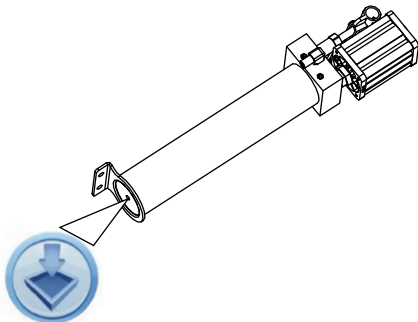

7. Perform the Air Purge Procedure.



ADDITIONAL WARNINGS:

- DO NOT USE MOTOR OIL IN THE JACK.
- ONLY USE ANTI-FOAMING JACK OIL.
- ALWAYS USE A GOOD GRADE HYDRAULIC JACK OIL.
- DO NOT USE HYDRAULIC BRAKE FLUID, ALCOHOL, GLYCERINE, DETERGENT, MOTOR OIL OR DIRTY OIL.
- USE OF A NON-RECOMMENDED FLUID CAN CAUSE DAMAGE TO A JACK.
- AVOID MIXING DIFFERENT TYPES OF FLUID AND NEVER USE BRAKE FLUID, TURBINE OIL, TRANSMISSION FLUID, MOTOR OIL OR GLYCERIN. IMPROPER FLUID CAN CAUSE PREMATURE FAILURE OF THE JACK AND THE POTENTIAL FOR SUDDEN AND IMMEDIATE LOSS OF LOAD.
- DISPOSE OF HYDRAULIC FLUID IN ACCORDANCE WITH LOCAL REGULATIONS.

LUBRICATION

A periodic coating of light lubricating oil to pivot points will help to ensure that pump piston linkage move freely.

Note: Never apply oil to the saddle. If saddle extension threads require lubrication; clean thread surfaces with a clean, dry cloth, then apply a drop of bearing grease to the threads. Distribute as evenly as possible along the threaded post.

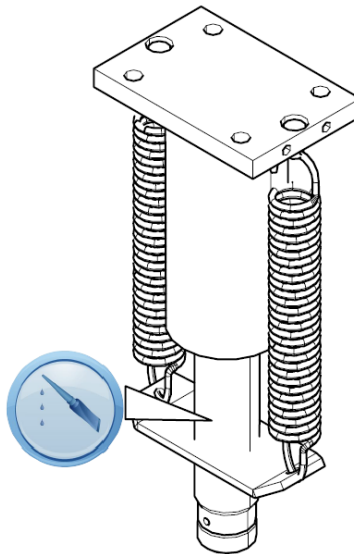

TROUBLESHOOTING

RAM WILL NOT PRESS LOAD	RAM BLEEDS OFF AFTER PRESS OPERATION	RAM WILL NOT RETRACT AFTER UNLOADING	POOR LIFT PERFORMANCE	RAM WILL NOT EXTEND TO FULL EXTENSION	CAUSES AND SOLUTIONS
X	X		X		Release valve not tightly closed Ensure release valve tightly closed
X					Overload condition Remedy overload condition
X	X		X		Power unit malfunctioning Replace the power unit
		X	X		Reservoir overfilled Remove pump, then drain fluid to proper level
		X			Linkage binding Clean and lubricate moving parts
X				X	Fluid level low Ensure proper fluid level
X			X	X	Air trapped in system Purge air from system

ASSEMBLY DIAGRAM

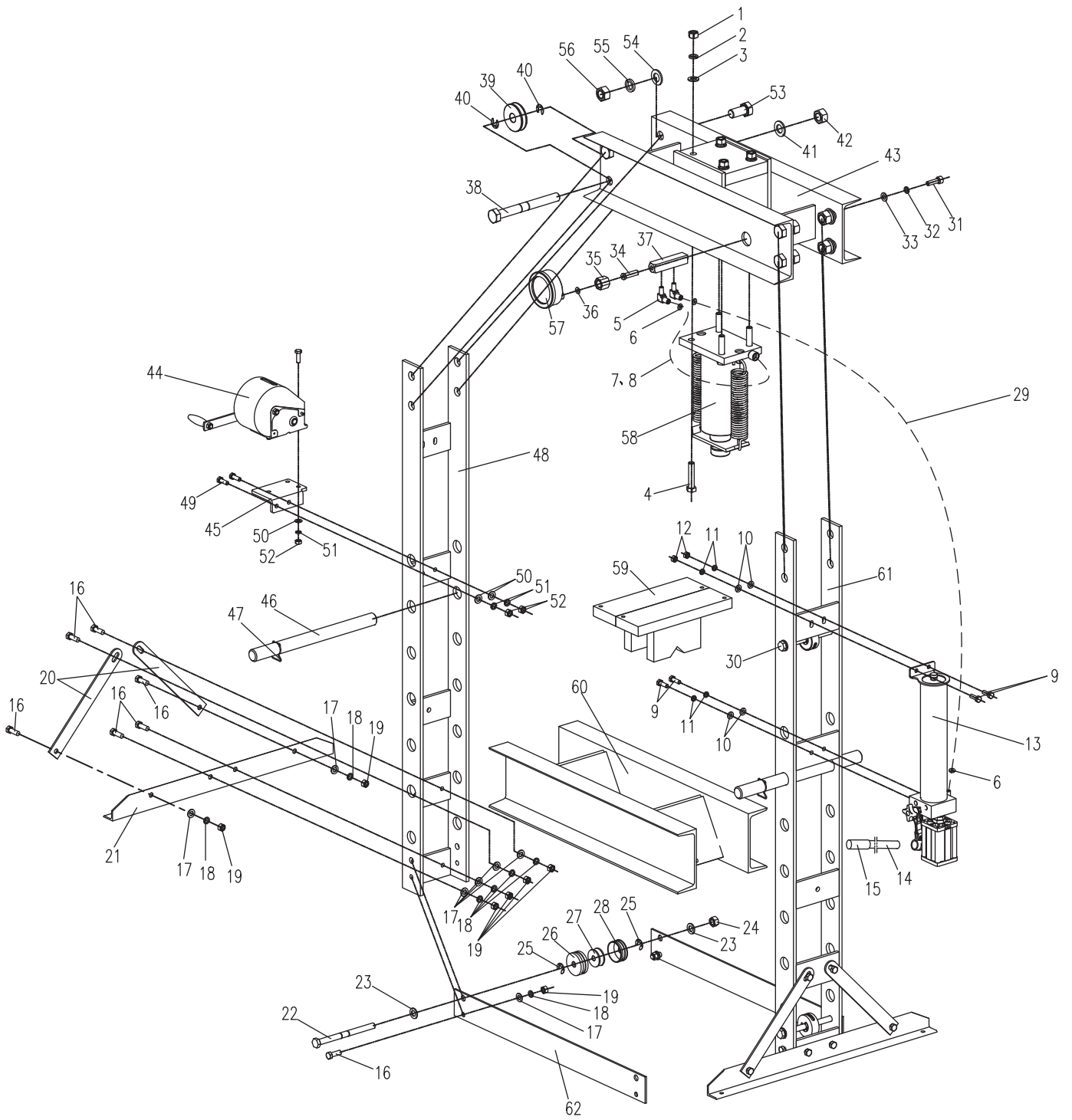

PARTS LIST

Index#	Part No.	Description	Qty.	Index#	Part No.	Description	Qty.
1	GB6170	nut M16	4	33	GB97.1	washer 12	1
2	GB93	lock washer 16	4	34	TY12001.1-13	gauge connection nut	1
3	GB97.1	washer 16	4	35	TY12001.1-14	connection nut	1
4	GB5783	bolt M16×75	4	36	TY12001.1-15	rectangular ring	1
5	TY20021-11	angle connector	2	37	TY40002-11	gauge retaining tee	1
6	TY20021-12	O-ring 5×1.8	2	38	TY40002-12	big roller shaft	1
7	TY45001-06	vitta for pressure cabin	1	39	TY40002-13	big wheel	1
8	QF4.4	valve	1	40	GB896	stretch circle	2
9	GB5783	bolt M10×30	4	41	GB97.1	washer 24	1
10	GB97.1	washer 10	4	42	GB6170	nut M24	1
11	GB93	lock washer 10	4	43	TY40002.1a	upper crossbeam	1
12	GB6170	nut M10	4	44	TY40002-05a	take-up	1
13	TY40001.1a	press pump part	1	45	TY20031-06	bent plate	1
14	TY40001.6	handle	1	46	TY45001-02	bed frame pin	2
15	QF4-7	handle cover	1	47	TY30001.3-05	fastener	2
16	GB5783	bolt M12×35	16	48	TY50001.2a	left post	1
17	GB97.1	washer 12	16	49	GB5783	bolt M10×30	5
18	GB93	lock washer 12	16	50	GB97.1	washer 10	5
19	GB6170	nut M12	16	51	GB93	lock washer 10	5
20	TY40002-01	knighthead	4	52	GB6170	nut M10	5
21	TY40002-03	base section	2	53	GB5783	bolt M24×50	6
22	TY40002-07a	lower roller shaft	2	54	GB97.1	washer 24	6
23	GB97.1	washer 16	6	55	GB93	lock washer 24	6
24	GB889	nut M16	3	56	GB6170	nut M24	6
25	GB896	stretch circle	6	57	TY50001-01a	pressure gauge	1
26	TY40002.5-01	roller shield	1	58	TY40001.2a	press cylinder part	1
27	TY40002-04	wheel	3	59	TY40001.4	heel block	1
28	TY40002.5-02	roller shield	1	60	TY40002.4	bed frame	1
29	TY20031J-01	hydraulic hose	1	61	TY50001.2	post	1
30	TY40002-08a	roller shaft	1	62	TY40002-02	board	1
31	GB5783	bolt M12×20	1	63	TY20030CL.3	wire clamp	2
32	GB93	lock washer 12	1				

PUMP ASSEMBLY DIAGRAM

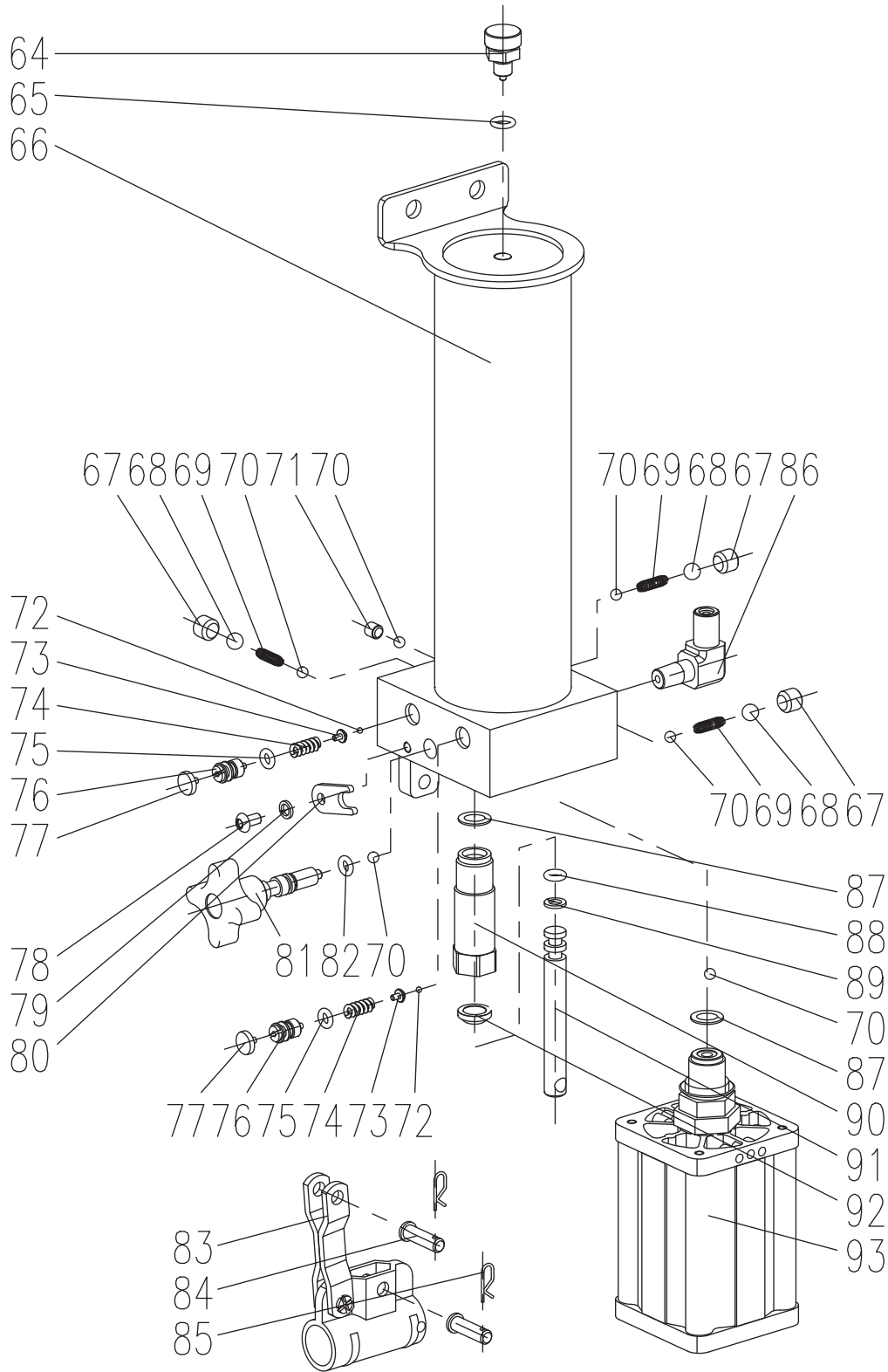

PUMP PARTS LIST

Index#	Part No.	Description	QTY.
64	TEL05006.1.3	Air bleed screw	1
65	GB3452.1	O-ring	1
66	TY40001.1a.1	Hydraulic pump unit	1
67	GB77	M12X1.25X10	3
68	GB308	Ball valve	3
69	TQ20002-21	Steel ball Spring	3
70	GB308	Ball valve	5
71	GB77	M8x8	1
72	GB308	Ball valve	2
73	TQ22001.1-26	Spring plate	2
74	QLQD2A.2-18	Spring safety valve	2
75	QLQ2.1-14	O-ring	2
76	T91004-38	Pressure adjusting screw	2
77	QLQD2A-17a	Safety valve cap	2
78	GB2672	Bolt M6X10	1
79	GB93	Spring washer6	1
80	TY20031.5-01	Limit block	1
81	TY20031.5.2	Release valve lever	1
82	QLQ2.1-17	O-ring	1
83	TY20001.4.3	Hand-held parts	1
84	QYL8-19	Pin	2
85	QLQD2B.2-05	Torsional spring latch	2
86	TY20021-11	Angle coupling	1
87	TQ20002-20	Copper pad	2
88	TQ12002-18	O-ring	1
89	TQ12002-17	Ring	2
90	TY20001.4-10a	Pump body	1
91	TY20001.4-11	Pump unit	1
92	QYL8-09	J-ring	1
93	TY20002.1.2a	Air pump	1

RAM ASSEMBLY DIAGRAM

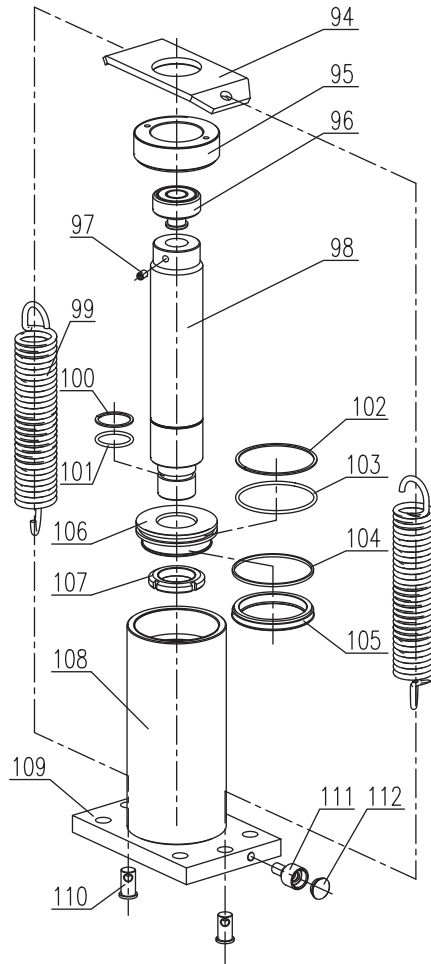

RAM PARTS LIST

Index#	Part No.	Description	Qty.
94	TY40001.2-02	spring hanger	1
95	TY40001.2-04	bushing	1
96	TY40001.2-01	copping	1
97	GB77	bolt M8x12	1
98	TY40001.2-03a	piston rod	1
99	TY40001.2-12	spring	2
100	TY40001.2-17	back ring	1
101	GB3452.1	O-ring 35.5x3.55G	1
102	TY40001.2-14	nylon ring	1
103	TY40001.2-13	O-ring	1
104	TY40001.2-16a	ring	1
105	TY40001.2-15a	Y-ring	1
106	TY40001.2-06a	piston head	1
107	GB812	nut M42x1.5	1
108	TY40001.2-05	cylinder assembly	1
109	TY40001.2-10a	soleplate	1
110	TY40001.2-11	extension spring bolt	2
111	QF4.6	coupling	1
112	QF4-34	dust cap	1

Safe Operating Temperature is between 40°F – 105°F (4°C - 41°C)

REPLACEMENT PARTS

For replacement parts Customer Service at **1-800-222-5381**. Not all equipment components are available for replacement; illustrations provided are a convenient reference of location and position in the assembly sequence. When ordering parts the following will be required: Model Number, Serial Number and Description. **The distributor reserves the rights to make design changes and or improvements to product lines and manuals without notice.**

For replacement parts and technical questions, please call 1-800-222-5381.

Limited Warranty

Limited Warranty

Northern Tool and Equipment Company, Inc. ("We" or "Us") warrants to the original purchaser only ("You" or "Your") that the Strongway product purchased will be free from material defects in both materials and workmanship, normal wear and tear excepted, for a period of one year from date of purchase. The foregoing warranty is valid only if the installation and use of the product is strictly in accordance with product instructions. There are no other warranties, express or implied, including the warranty of merchantability or fitness for a particular purpose. If the product does not comply with this limited warranty, Your sole and exclusive remedy is that We will, at our sole option and within a commercially reasonable time, either replace the product without charge to You or refund the purchase price (less shipping). This limited warranty is not transferable.

Limitations on the Warranty

This limited warranty does not cover: (a) normal wear and tear; (b) damage through abuse, neglect, misuse, or as a result of any accident or in any other manner; (c) damage from misapplication, overloading, or improper installation; (d) improper maintenance and repair; and (e) product alteration in any manner by anyone other than Us, with the sole exception of alterations made pursuant to product instructions and in a workmanlike manner.

Obligations of Purchaser

You must retain Your product purchase receipt to verify date of purchase and that You are the original purchaser. To make a warranty claim, contact Us at 1-800-222-5381, identify the product by make and model number, and follow the claim instructions that will be provided. The product and the purchase receipt must be provided to Us in order to process Your warranty claim. Any returned product that is replaced or refunded by Us becomes our property. You will be responsible for return shipping costs or costs related to Your return visit to a retail store.

Remedy Limits

Product replacement or a refund of the purchase price is Your sole remedy under this limited warranty or any other warranty related to the product. We shall not be liable for: service or labor charges or damage to Your trailer incurred in removing or replacing the product; any damages, including, without limitation, damages to tangible personal property or personal injury, related to Your improper use, installation, or maintenance of the product; or any indirect, incidental or consequential damages of any kind for any reason.

Assumption of Risk

You acknowledge and agree that any use of the product for any purpose other than the specified use(s) stated in the product instructions is at Your own risk.

Governing Law

This limited warranty gives You specific legal rights, and You also may have other rights, which vary from state to state. Some states do not allow limitations or exclusions on implied warranties or incidental or consequential damages, so the above limitations may not apply to You. This limited warranty is governed by the laws of the State of Minnesota, without regard to rules pertaining to conflicts of law. The state courts located in Dakota County, Minnesota shall have exclusive jurisdiction for any disputes relating to this warranty.



Distributed by
Northern Tool + Equipment Co., Inc.
Burnsville, Minnesota 55306
NorthernTool.com
Made in China