

Installation Guide

CIH Old Magnum Series Monitor Bracket (PN: 3190)

FITS CASE IH® 71, 72 & 89 SERIES MAGNUM TRACTORS

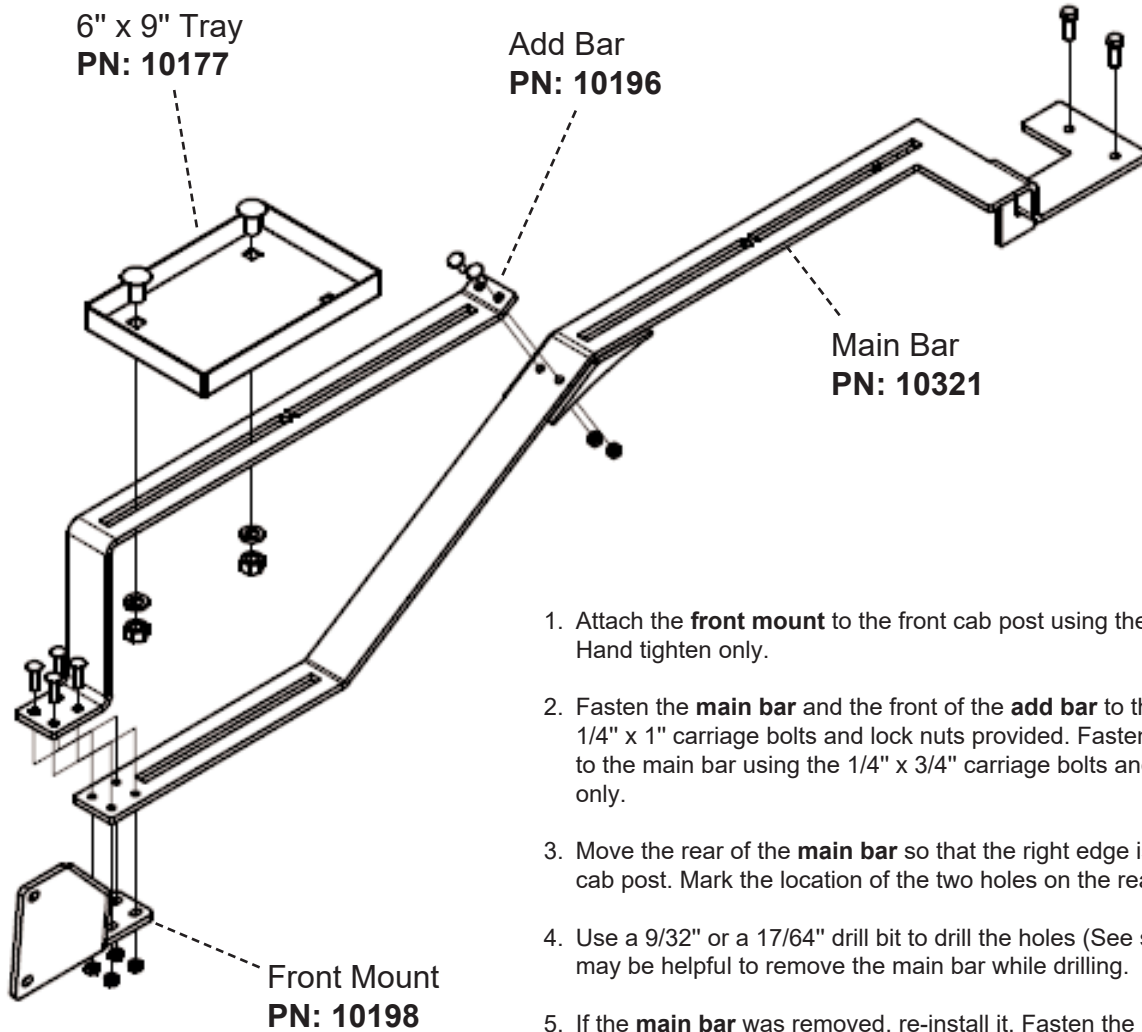

1. Attach the **front mount** to the front cab post using the existing bolts and nuts. Hand tighten only.
2. Fasten the **main bar** and the front of the **add bar** to the **front mount** using the 1/4" x 1" carriage bolts and lock nuts provided. Fasten the rear of the **add bar** to the main bar using the 1/4" x 3/4" carriage bolts and lock nuts. Hand tighten only.
3. Move the rear of the **main bar** so that the right edge is up tight to the rear right cab post. Mark the location of the two holes on the rear of the **main bar**.
4. Use a 9/32" or a 17/64" drill bit to drill the holes (See step 5 for clarification). It may be helpful to remove the main bar while drilling.
5. If the **main bar** was removed, re-install it. Fasten the back of the **main bar** using the 5/16" x 1" thread cutting bolts provided. Alternatively, the holes can be tapped using a 5/16"-18 tap and fasten with standard 5/16" bolts. If this method is chosen, drill the holes using a 17/64" drill bit.
6. Place the 6" x 9" tray where desired and fasten using the 1/2" x 1 1/4" carriage bolts, lock washers, and nuts provided. The tray can be mounted anywhere on the monitor bracket.
7. Tighten all hardware.