



M157495Z

ITEM NUMBER: 157495

SERIAL NUMBER: _____

Owner's Manual Industrial Water Heater Instructions for Set-up, Operation, Maintenance & Storage

Thank you for purchasing a NorthStar water heater. Your machine is designed for long life, dependability, and the top performance you demand! Take time now to read through this manual so you better understand the machine's operation, maintenance and safety precautions. Everyone who operates this machine must read and understand this manual. The time you take now will prolong your machine's life and prepare you for its safe operation. Enjoy the exceptional performance of your NorthStar water heater, the industry leader! The manufacturer reserves the right to make improvements in design and/or changes in specifications at any time without incurring any obligation to install them on units previously sold.

⚠ WARNING: SPECIAL HAZARDS

- **Burns:** Hot spray can scald and burn skin. Hot surfaces of wand and burner, as well as hot exhaust from the burner can cause burns.
- **Fire/Explosion:** Burner sparking can ignite fuel or other flammable liquids or vapors in the vicinity. Hot exhaust from burner can ignite combustible materials. Keep a fire extinguisher rated "ABC" nearby during operation.
- **Electrocution:** Improper connection of the equipment or grounding conductor can result in a risk of electrocution.
- **CO Poisoning:** Exhaust from burner contains carbon monoxide, a poisonous gas that can cause carbon monoxide poisoning and possible death if inhaled.

Equipment Protection Quick Facts

Inspect Upon Delivery: STOP! Closely inspect to make sure no components are missing or damaged. Contact NorthStar Product Support to report missing or damaged parts.

Maintenance Schedule: Burner fuel filter, burner coil and electrodes require periodic checking and servicing to keep pressure washer functioning efficiently. See "*Maintenance & Repair*" for frequency of servicing.

Any Questions, Comments, Problems or Parts Orders

Call NorthStar Product Support 1-800-270-0810

Table of Contents

Equipment Protection Quick Facts	1
TABLE OF CONTENTS	2
ABOUT YOUR PRESSURE WASHER	4
SPECIFICATIONS	5
COMPONENT IDENTIFICATION	6
SPECIAL EQUIPMENT SAFETY FEATURES	7
1. High Pressure Safety Device	7
2. Thermostat	7
IMPORTANT SAFETY INFORMATION	8
GROUNDING INSTRUCTIONS	9
EXTENSION CORDS	9
SAFETY	10
Hazard Signal Word Definitions	10
SAFETY DECAL LOCATIONS	11
UN-PACKING INSTRUCTIONS	12
HARDWARE BAG	13
ASSEMBLY	14
BEFORE EACH USE	15
Step 1: Inspect Equipment	15
Electrical	15
Burner Fuel System	15
Periodic Maintenance	15
Step 2. Check and Fill Burner Fuel Tank	15
Filling Burner Fuel Tank	15
Step 3. Select Suitable Worksite Guidelines	15
For Indoor and Outdoor Uses	16
Step 4. Oil Burner Adjustment	16
Step 5. Verify Electrical Connection	16
Grounding	16
Ground Fault Circuit Interrupter Protection	16
Extension Cord and Usage	17
Electric Shock Accident	17
OPERATION INSTRUCTIONS	18
1. Pre-Operation	18
2. Check Your Water Supply	18
3. Connect Your Pressure Washer	18
4. To Start	19
5. Turn Your Pressure Washer ON	19
6. Turn Water Heater ON	19
7. To Clean	19
8. To Stop	19
MAINTENANCE & REPAIR	20

1. Recommended Service Parts List	20
2. Maintenance Mode.....	20
3. Maintenance Schedule	20
4. Checking the Tire Air Pressure	20
5. Burner Fuel Filter	20
6. Checking the Hoses.....	20
7. Coil Descaling	21
8. Coil Desooting.....	21
9. Electrodes	22
10. Flow Switch	22
MOVING AND HANDLING INSTRUCTIONS.....	25
1. Maneuvering Your Water Heater	25
2. Lifting Your Water Heater.....	25
MAINTENANCE INSTRUCTIONS	25
TROUBLESHOOTING GUIDE.....	26
PARTS EXPLOSION- 157495- REV Z.....	27
PARTS LIST-157495- REV Z.....	28
WIRING DIAGRAMS.....	29
LIMITED WARRANTY	31
.....	32

About Your Pressure Washer

Thank you for purchasing a NorthStar Industrial Water Heater! It is designed for long life, dependability, and top performance.

Intended Use. Add-on to cold water pressure washer that will allow for hot water cleaning to aid in washing siding, windows, walkways, driveways, patios, decks, fences, vehicles, boats, lawnmowers, ATVs and other equipment.

Note: Do not use for other purposes, as unforeseen hazards or equipment damage may result.

Water Supply. The pump requires a clean, standard tap water supply provided through a garden hose at a flow rate of at least 3 gallons per minute. Use of a backflow preventer on the water supply hose is recommended and may be required by local code.

Chemical Usage. Any cleaning chemicals that are used must be specifically approved for use in pressure washers.

Power Source. The water heater is powered by electricity and a diesel fired burner.

Supplies Required. Normal operation will require you to supply:

- Fuel
- Electricity
- Cold water pressure washer

See “*Specifications*” section of this manual for more detail.

Site Selection. This unit is made for OUTDOOR USE ONLY unless specific exhausting guidelines are met. Read additional details in the “*Before Each Use*” section of this manual.

Personal Protection. Wear safety apparel during operation, including waterproof insulated gloves, safety glasses with side and top protection, and non-slip protective footwear. Some cleaning chemicals may require the use of a respirator mask (as instructed on chemical label).

Adult control only. Only trained adults should set up and operate the water heater. Do not let children operate. Water heaters can generate forces greater than children can control and require judgment beyond what can be expected of them.

Under The Influence. Never operate, or let anyone else operate, the pressure washer while fatigued or under the influence of alcohol, drugs, or medication.

Keep this manual for reference and review.

ATTENTION: Rental Companies and Private Owners who loan this equipment to others!

All persons to whom you rent/loan this water heater must have access to and read this manual. Keep this owner's manual with the water heater all times and advise all persons who will operate the machine to read it. You must also provide personal instruction on how to safely set-up and operate the water heater and remain available to answer any questions a renter/borrower might have. Owner's Manuals are available from NorthStar at 1-800-270-0810.

Specifications

Item Number	157495
Max. Pressure Rating	4000 PSI
Max. Flow Output	4 GPM
BTU Output	353,700 BTU
Temperature Rise	190°F @ 2GPM 190°F @ 3GPM 140°F @ 4GPM
Maximum Temperature	250°F
Approved Fuels	#1 or 2 Diesel, Kerosene, Fuel Oil
Fuel Capacity	4 gal.
Power Requirements	
NEMA Receptacle	5-15R
Volts	115V
Amps	5A
Hertz	60Hz
Phase	single
Dimensions	
Length	38.25"
Width	27"
Height	38.75"
Weight (dry)	286 lbs.
Weight (fueled)	334 lbs.
Ship Weight	310 lbs.

Component Identification

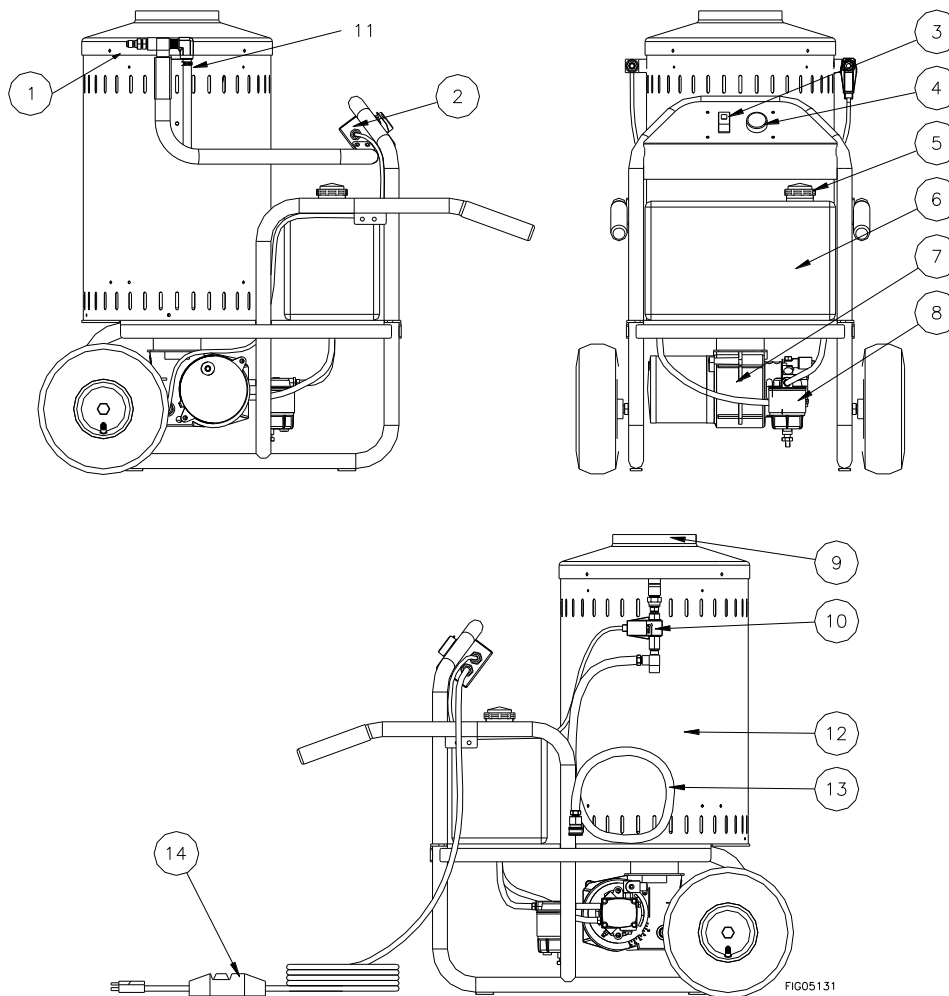

FIG05131

- | | |
|---|--|
| <ol style="list-style-type: none"> 1. Water Outlet: Attach your high pressure hose. 2. Control box: Box to house control switches. 3. Heat Switch: When turned to ON position water heater will begin heating with proper water flow. 4. Thermostat: Controls power to fuel solenoid for firing. 5. Fuel Fill Cap: Vented cover for fuel tank. 6. Fuel Tank: The Burner has a 4 gal. fuel tank- kerosene, #1 or #2 diesel, or fuel oil may be used. Do not mix fuel types. 7. Burner: The oil burner is preset and performance tested at the factory. The Burner may need initial adjustment for peak performance. See “<i>Oil Burner Adjustment</i>” section for instructions on initial adjustment of the oil burner. Tip pressure washer using handle to access burner from underneath unit. | <ol style="list-style-type: none"> 8. Fuel Filter: Filter in fuel line that removes water and screens out dirt and debris from fuel. 9. Exhaust Vent: Provides an exit for burner exhaust gases. 10. Flow Switch: Water activated switch to control on and off of burner. 11. Rupture Disc: Safety device for over pressure protection 12. Heating Coil: Tubing in which water circulates through to heat. 13. Water Inlet (pressure washer): Connect hose to cold water pressure washer. 14. Power Cord (w/GFCI): Plug into outlet to power unit. |
|---|--|

Special Equipment Safety Features

1. High Pressure Safety Device

The high pressure safety device (rupture disc) is a backup safety feature. If the system's pressure exceeds its limits, the rupture disc will open and relieve system pressure.

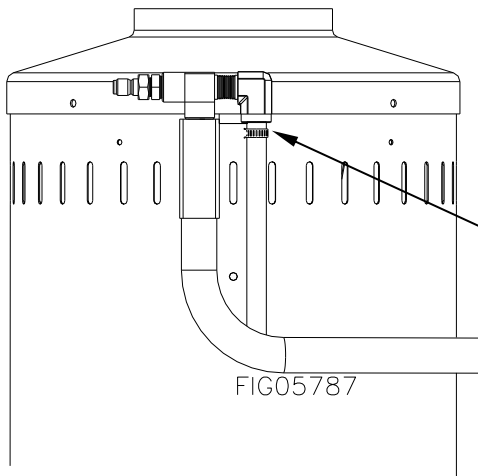

Thermostat

Rupture Disc

2. Thermostat

The thermostat is another safety feature that keeps the outlet water temperature below 250°F.

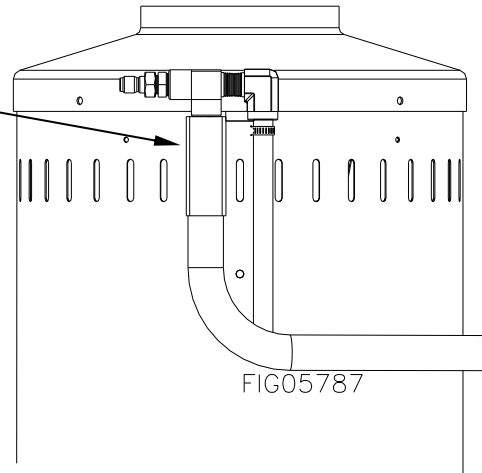

WARNING: If the rupture disc ever discharges water, turn the unit off and do not use the machine. See a dealer or call Customer Service at 1-800-270-0810.

Important Safety Information

- 1.) Read all the instructions before using the product.
- 2.) Make sure that your existing hose, gun, and all accessories are rated for high temperatures and the appropriate pressure.
- 3.) To reduce the risk of injury, close supervision is necessary when the product is used near children. Do not allow irresponsible use by children. Always stop the product and bleed pressures before leaving unattended, disconnecting hoses, or servicing.
- 4.) Know how to stop the product and bleed pressures quickly. Be thoroughly familiar with the controls.
- 5.) Stay alert - watch what you are doing.
- 6.) Do not operate the product when fatigued or under the influence of alcohol or drugs. Never smoke while operating or fueling this machine.
- 7.) Keep operating area clear of all persons.
- 8.) Do not overreach or stand on unstable support. Keep good footing and balance at all times. Wear footwear capable of maintaining a good grip on wet surfaces. Do not place the machine on soft or unstable ground.
- 9.) Follow the maintenance instructions specified in all manuals.
- 10.) Wear safety glasses, gloves, face protection and appropriate clothing when operating the machine.
- 11.) Do not operate this machine with broken or missing parts. Never alter the manufacturer's original design or deactivate any safety device on the machine.
- 12.) Risk of exposure to dangerous chemicals. Wear protective gloves when handling and cleaning with chemicals. Follow the chemical manufacturer's directions. Understand all safety hazards and first aid for all chemicals being used. Do not pump highly abrasive fluids or use with incompatible chemicals or solvents.
- 13.) Know the pressure and temperature limits of your machine. Be sure all high pressure accessories meet or exceed your machine's limits. Do not set the rupture disc above the machine's limit.
- 14.) Do not move this machine by pulling on the hose. Do not attempt to use this machine as a prop.
- 15.) Do not clean this machine with its own spray. Cleaning should be done with a damp sponge with the machine OFF.
- 16.) NEVER attempt to immediately run or re-light the burner if it doesn't ignite the first time. Unburned oil or gas may have accumulated causing potential explosion or fire hazard.
- 17.) Always make sure all switches and controls are in the OFF position prior to plugging in the electrical cord. Do not stand in water while plugging and unplugging electrical cord.
- 18.) This product is provided with a ground fault circuit interrupter built into the power cord plug. If replacement of the plug or cord is needed, use only identical replacement parts. Failure to do so will void all warranties.

SAVE THESE INSTRUCTIONS

Grounding Instructions

This product must be grounded. If it should malfunction or breakdown, grounding provides a path of least resistance for electric current to reduce the risk of electrical shock. This product is equipped with a cord having an equipment-grounding conductor and a grounding plug. The plug must be plugged into an appropriate outlet that is properly installed and grounded in accordance with all local codes and ordinances.

DANGER - Improper connection of the equipment; grounding conductor can result in a risk of electrocution. Check with a qualified electrician or service personnel if you are in doubt as to whether the outlet is properly grounded. Do not modify the plug provided with the product. If it will not fit the outlet, have a proper outlet installed by a qualified electrician. Do not use any type adapter with this product.

GROUND FAULT CIRCUIT INTERRUPTER PROTECTION

This water heater is provided with a ground fault circuit interrupter (GFCI) built into the plug of the power supply cord. This device provides additional protection from the risk of electric shock. Should replacement of the plug or cord become necessary, use only identical replacement parts that include GFCI protection.

Extension Cords

Use only 3-wire extension cords that have 3 prong grounding-type plugs and 3-pole cord connectors that accept the plug from the product. Use only extension cords that are intended for outdoor use. These extension cords are identified by a marking "Acceptable for use with outdoor appliances; store indoors while not in use." Use only extension cords having an electrical rating not less than the rating of the product. Do not abuse extension cord and do not yank on any cord to disconnect. Keep cord away from heat and sharp edges. Always disconnect the extension cord from the receptacle before disconnecting the product from the extension cord.

Warning - To reduce the risk of electrocution, keep all connections dry and off the ground. Do not touch plug with wet hands.

SAVE THESE INSTRUCTIONS

Safety

Hazard Signal Word Definitions



This is the safety alert symbol. It is used to alert you to potential personal injury hazards. Obey all safety messages that follow this symbol to avoid possible injury or death.

DANGER (red) indicates a hazardous situation, which if not avoided, will result in death or serious injury.

WARNING (orange) indicates a hazardous situation, which if not avoided, could result in death or serious injury.

CAUTION (yellow), used with the safety alert symbol, indicates a hazardous situation, which if not avoided, could result in minor or moderate injury.

CAUTION (yellow), without the safety alert symbol, is used to address practices not related to personal injury.

NOTICE is used to address practices not related to personal injury.

Safety Decal Locations

HOT WATER OUTLET

⚠ WARNING

Skin puncture and burn hazard.
Hot high pressure fluid can puncture and burn skin resulting in serious injury including amputation.
Use only components that are rated to 250°F and 4000 psi.
Do not attach pressure washers that exceed 4000 psi.
Do not direct spray at people.

⚠ WARNING

1.) Risk of electrocution.
Electrical shock can kill you.
Do not expose the water heater or any electrical product to the water heater's spray.
Connect only to grounded outlet. Do not remove ground pin. Inspect cord before using. Do not use if cord is damaged. Keep plug dry and off ground. Do not touch plug with wet hands. This product is provided with a ground fault circuit interrupter built into the cord. If replacement of the plug or cord is needed, use only identical replacement parts.

2.) Skin puncture and burn hazard.
Hot high pressure fluid can puncture and burn skin resulting in serious injury including amputation.
Use only components that are rated to 250°F and 4000 psi.
Do not attach pressure washers that exceed 4000 psi.
Do not direct spray at people.

3.) Risk of fire and/or explosion.
You can be burned or seriously injured when handling fuel. Use only diesel, kerosene, or fuel oil.
Check fuel lines for leaks before operating. Wipe up spills immediately.
Operate only where open flame or torch is permitted. Do not add fuel when the product is operating or is still hot. Do not spray flammable liquids.

4.) Breathing hazard.
Poisonous fumes from water heater can kill you. Do not operate in enclosed areas unless vented by a local heating contractor.

5.) Read owner's manual completely.
Serious injury or death can result if safety instructions are not followed.
You must be 16 or older to operate this machine. Keep untrained people away.

START-UP:

1. Connect electrical cord.
2. Attach high pressure hose from pressure washer to inlet of water heater.
3. Attach high pressure hose and gun to outlet of water heater.
4. Turn water supply ON.
5. Squeeze the trigger to allow air to purge from the system.
6. Start the pressure washer.
7. Turn heat switch ON for hot water.

SHUT-DOWN:

1. Turn off the "heat" switch and pump cold water through the coil for three minutes.
2. Turn pressure washer OFF.
3. Turn OFF the water supply.
4. Squeeze the trigger to relieve system pressure.
5. Disconnect cord from power supply.

Please read your owner's manual before operating.
Product Support: 1-800-270-0810.
M-F 7AM-5:00PM CT

NORTH STAR
Proven Performance™

⚠ CAUTION HOT!

⚠ WARNING

IF RUPTURE DISK ACTIVATES AND RELEASES WATER:

- Turn heat switch OFF
- Turn power switch OFF
- Turn water supply OFF
- Pull spray gun trigger to release pressure
- Unplug pressure washer, or remove the spark plug wire

Do not use pressure washer until Product Support arranges for repair or replacement.
Failure to turn off immediately could result in serious injury.
Call 1-800-270-0810

Ref#	Part#	Description
1	787751	Warning Burn
2	787751	Warning Risks
3	802025	Control Panel, Operation Instructions
4	305410	Caution Hot!
5	798047	Rupture Disk Warning
	32821	Lanyard

Always make sure safety labels are in place and in good condition. If a safety label is missing or not legible, order new labels or unsafe operation could result. To order replacement safety labels, call NorthStar Product Support at 1-800-270-0810.

Un-Packing Instructions

Inspect water heater immediately after delivery for missing parts or damage.

- For *missing or damaged* components, contact Product Support at 1-800-270-0810.

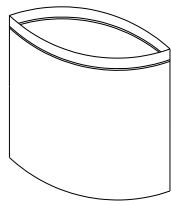

**Hardware Bag
Qty-1**

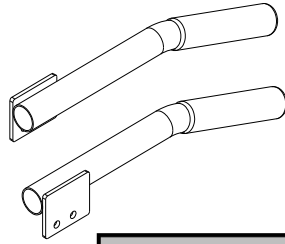

**Handle & Grip
Qty-2**

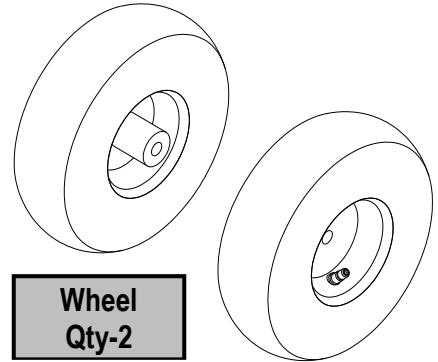

**Wheel
Qty-2**

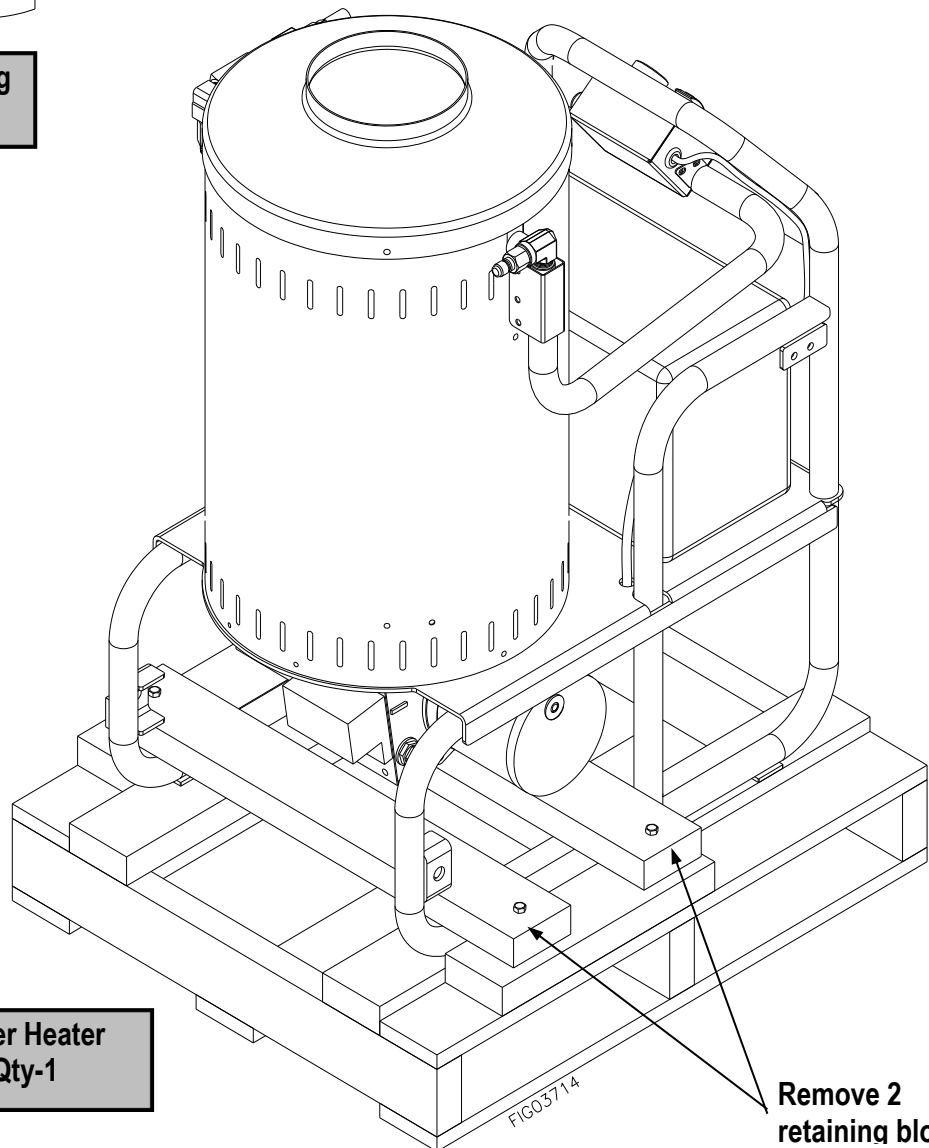

**Water Heater
Qty-1**

**Remove 2
retaining blocks.**

Hardware Bag

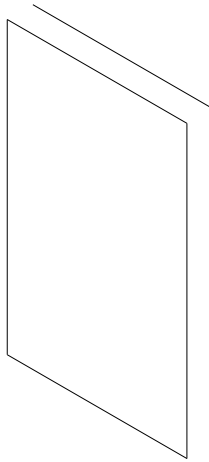

Owner's Manual

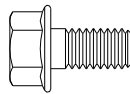

4X - 5/16 X .75" Flange Bolt



4X - 5/16 Flange Nut

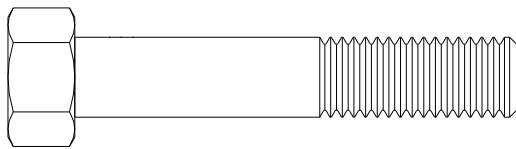

2X - 5/8 X 3.5" Hex Bolt

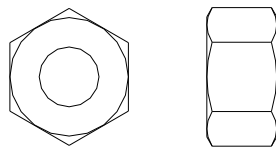

2X - 5/8 Hex Nut

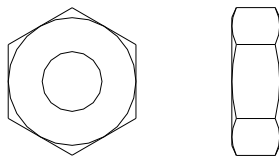

2X - 5/8 Jam Nut

FIG01352

Assembly

To attach handles, use:
5/16 X .75" Flange Bolts (4x)
5/16 Flange Nuts (4x)

To attach wheels:
1.) Slide 5/8 X 3.5" bolt through hub of wheel.
2.) Spin 5/8 Jam Nut onto bolt. Do not tighten against wheel.
3.) Slide bolt through hole in frame, secure with 5/8 Hex Nut.

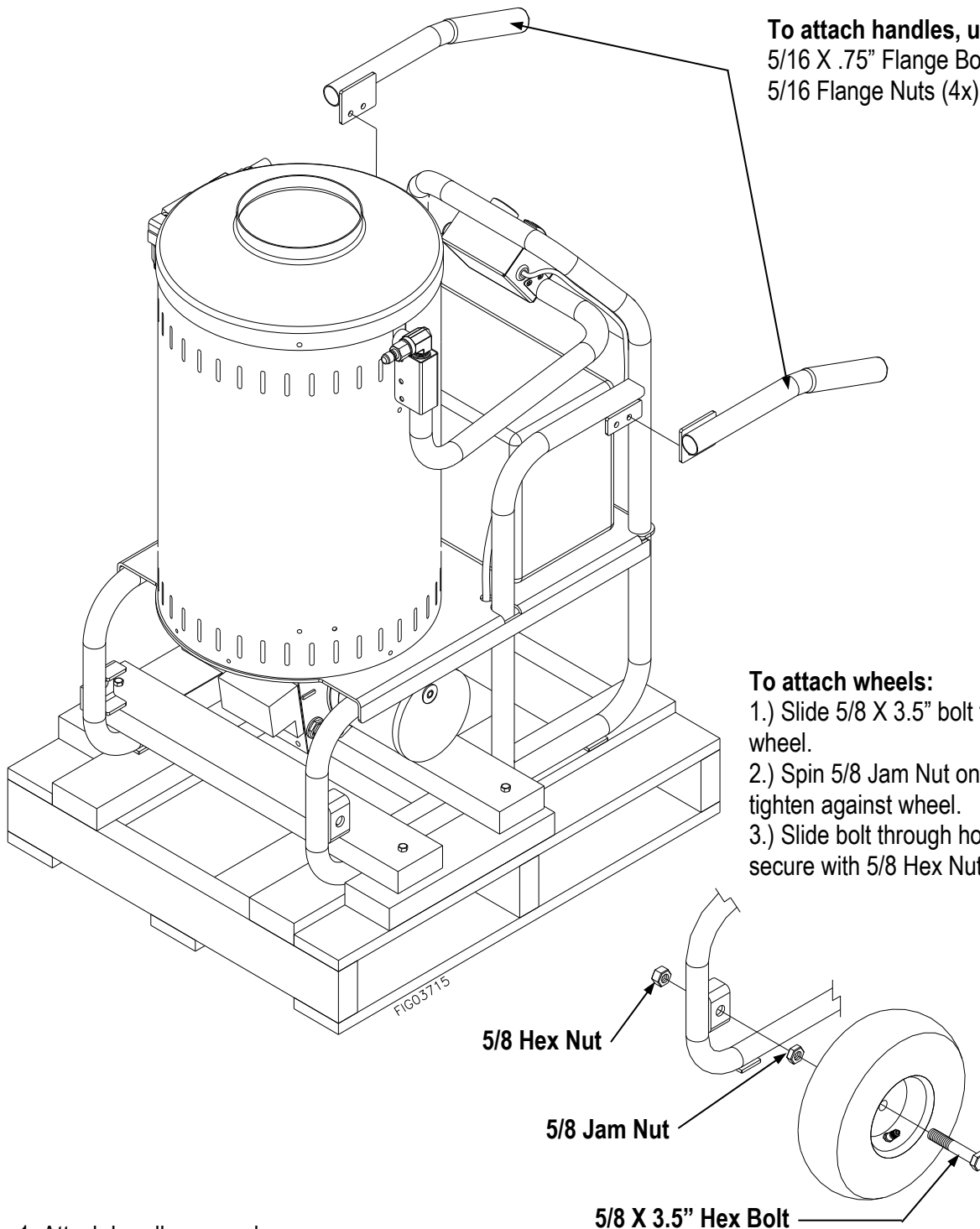

1. Attach handles, see above.
2. Attach wheels, see above.
3. Remove water heater from the pallet. It is recommended that a hoist is used, or that two people lift the unit off of the pallet. If a hoist is used, use the attachment points shown in the Moving and Handling section on page 16. Do not try to lift the unit by the hook on the heating coil inside the heat exchanger. The heating coil is not secured to the frame.

Before Each Use

Step 1: Inspect Equipment

Electrical

- Inspect power cord before using. Do not use if cord is damaged.
- Connect only to properly grounded outlet.
- Keep all connections dry and off the ground.
- Do not touch plug with wet hands.
- If product is provided with a GFCI built into the power cord plug, use only identical parts if replacement is necessary.

Burner Fuel System

Inspect burner fuel system for leaks BEFORE starting pressure washer. Look for:

- Signs of leaks, wetted areas, or deterioration
- Chafed or spongy fuel hose
- Loose connections
- Loose or missing fuel hose clamps
- Damaged fuel tank

⚠ WARNING: Fuel leak hazard

Burner fuels are highly flammable and fuel leaks can result in fire or explosions. You can be burned and seriously injured if there is a fuel leak when you start the pressure washer.

Periodic Maintenance

Other periodic maintenance is listed within the "Maintenance & Repair" section.

Note: Do not use water heater until all needed repairs have been completed.

Step 2. Check and Fill Burner Fuel Tank

If you are planning to use heated water, check level of burner fuel tank. If fuel is needed, use #1 or #2 diesel, B5 or lower biodiesel, kerosene or fuel oil. Use these precautions each time you fill:

1. Regularly inspect fuel systems for leaks.
2. Fill fuel tank OUTDOORS- never indoors, and stay away from all sources of heat, sparks and flames.
3. Use an UL approved portable container to transfer fuel to machine.

Filling Burner Fuel Tank

⚠ WARNING: Flammability hazard

Burner fuels are highly flammable. Turn the machine off and allow it to cool for at least 2 minutes before removing fuel cap; as a running or still hot burner is hot enough to ignite fuel.

After Machine Has Cooled:

1. Remove burner fuel cap.
2. Add fuel through the fill opening. Do not overfill. Allow at least 1/2" of empty space below fill neck to allow for fuel expansion.
3. Replace fuel cap securely before starting burner.
4. Clean up fuel spills/splashes immediately.
 - If possible, move the machine away from spilled fuel on the ground.
 - Wipe up spilled fuel and wait 5 minutes for excess fuel to evaporate before starting burner.
 - Fuel soaked rags are flammable and should be disposed of properly.
 - If fuel is spilled on your skin or clothes, change clothes and wash skin immediately.
5. Store extra fuel in a cool, dry place in an UL-approved, tightly sealed container.

Step 3. Select Suitable Worksite Guidelines

⚠ WARNING: Location hazard

You must choose a suitable site for operating your water heater to avoid equipment damage and/or injury and possible death from carbon monoxide poisoning, fire/explosion, uncontrolled equipment movement/tip over, or slips and falls. While designed primarily for outdoor usage, this electric powered water heater may be used inside large commercial buildings if special additional precautions are taken. See below.

Make sure the water heater is on a level surface and in a protected area where it is not readily influenced by outside forces such as freezing temperatures, strong winds, rain, etc. Locate the water heater for easy access to fill fluids and make adjustments. It is recommended that a partition is made between the wash area and the water heater to prevent direct nozzle spray from coming in contact with the water heater. Excessive moisture will reduce the water heater's service life.

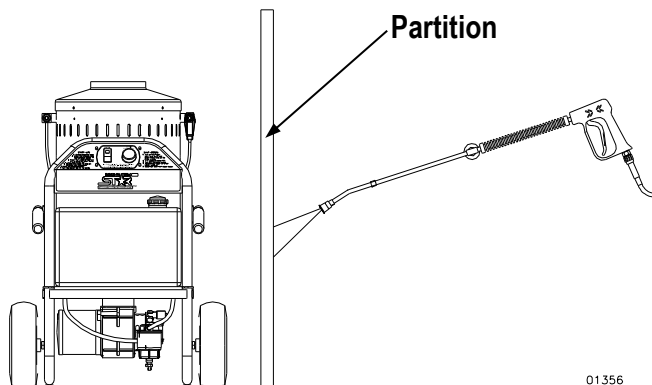

For Indoor and Outdoor Uses

Placement of the Machine:

- Where it will NOT be exposed to rain, snow, or direct sunlight. Exposure to water can cause electric shock.
- Where no flammable vapors, dusts, and gases are present.
- At least 7 feet away from combustible materials (when burner used).
- Away from all building windows and air intakes (when burner used).
- Away from other heat-generating equipment.

Positioning:

- Situate the machine on a firm, level, heat-resistant surface with good drainage.
- Block wheels to prevent movement.

Airflow:

- Provide for adequate, unobstructed airflow for cooling and combustion air.
- Do not allow debris to accumulate or block airflow.
- Do not operate with a tarp, blanket, or cover surrounding the machine.
- Do not place any objects against or on top of the unit.

Electrical Precautions:

- To reduce the risk of electrocution, keep all cord connections dry and off the ground.
- Do not touch plug with wet hands.

Step 4. Oil Burner Adjustment

Burner Air Adjustment: The oil burner is preset and performance tested at the factory (elevation 1100 feet). A one-time initial correction of the burner for your location will pay off in economy, performance, and extended service life.

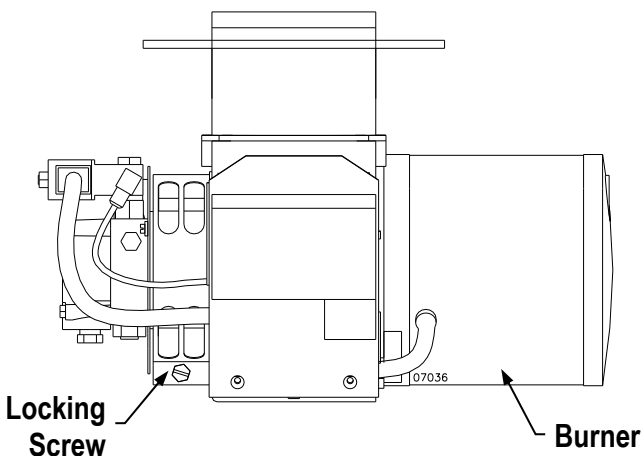

- 1.) Turn the pump and heat switches on (Refer to "Operation" for details). Have someone operate the spray gun so the burner fires.
- 2.) Loosen the locking screw and close the air band until black smoke appears from the burner exhaust vent. Note the position of the white arrow on the air band.
- 3.) Slowly open the air band until white smoke just starts to appear.
- 4.) Turn the air band half way back to the black smoke position previously noted. Tighten the locking screw.

CAUTION: If white smoke appears from the burner exhaust vent during start-up or operation, discontinue use and readjust air bands.

NOTE: If a flue is installed, have a professional serviceman adjust your burner for a #1 or #2 smoke spot on the Bacharach scale.

Step 5. Verify Electrical Connection

Grounding

Product must be grounded. The supply cord is equipped with an equipment-grounding conductor and a grounding plug. This plug must be plugged into an outlet that is properly installed and grounded in accordance with all local codes and ordinances.

Ground Fault Circuit Interrupter Protection

Connecting the water heater through some type of ground fault circuit interrupter (GFCI) protector is required to comply with the National Electric Code (NFPA 70) and to provide additional protection from the risk of electric shock.

Note: Before use, your GFCI should be tested at either built-in or receptacle base.

1. For a product rated at 125 volts or less, the GFCI is built into the power cord plug.
 - This GFCI device provides additional protection from the risk of electric shock. If replacement of the plug or cord is needed, use only identical replacement parts.
2. For a product rated at more than 125 volts, a receptacle based GFCI is required.



DANGER: Electrocutation hazard

Improper connection of the equipment or grounding conductor can result in a risk of electrocution. Check with a qualified electrician or service personnel if you are in doubt as to whether an outlet is properly grounded. Do not modify the plug provided with the product. If it will not fit the outlet, have a proper outlet installed by a qualified electrician. Do not use any type adapter with this product.

Extension Cord and Usage

Use only 3-wire extension cords that:

- Have 3 prong grounding-type plugs and 3-pole cord connectors that accept the plug from the product.
- Are intended for outdoor use, identified by the marking, "Acceptable for use with outdoor appliances; store indoors while not in use."
- Have an electrical amperage rating not less than the rating of the product.

Usage Precautions:

- Do not yank on any cord to disconnect.
- Keep cord away from heat and sharp edges.
- Always disconnect the extension cord from the receptacle before disconnecting the product from the extension cord.

Electric Shock Accident

If an electric shock occurs to a victim, immediately shut down the source of electrical power. If this is not possible, avoid direct contact with victim. Use a non-conducting implement, such as a dry rope or board, to free the victim from the live conductor. Apply first aid and get immediate medical help.

Operation Instructions

1. Pre-Operation

- ☑ A.) Position the machine for easy access to all controls.
- ☑ B.) Position the machine on a solid surface, with less than a three degree slope, and so it is protected from external damage.
- ☑ C.) Position the machine so that ambient lighting is sufficient for the surface you are cleaning to be seen with ease. Use artificial light if needed.
- ☑ D.) Check hoses, fittings, and fuel connections for signs of wear, cracks and looseness, and replace as required.
- ☑ E.) Read entire manual, especially the important safety instructions listed on page

2. Check Your Water Supply

- ☑ A.) Make sure the water supply is clean. Debris can reduce performance.
- ☑ B.) Do not pump flammable liquids or liquids containing incompatible chemicals or solvents.

3. Connect Your Pressure Washer

WARNING: Make sure all switches and controls are in the OFF position prior to plugging in the cord. DO NOT stand in water while plugging or unplugging electrical cord.

WARNING: Use a UL recognized receptacle protected by a ground fault interrupter and extension cord of proper voltage and amperage at all times.

WARNING: Check hoses, fittings, and fuel connections daily for signs of wear, cracks and looseness; replace as required.

1. Connect electrical cord to NEMA receptacle, 5-15R.
2. Connect outlet of your pressure washer to inlet of the water heater. Your NorthStar Water Heater is equipped with quick connect fittings, as are all NorthStar pressure washers. Slide the collar back on the inlet hose and push it over the outlet nipple of the pressure washer. Pull on hose to assure a good connection.
 - 2a. If your pressure washer does not have quick connect fittings, you can order them at 1-800-270-0810.
 - 2b. If you do not want quick connect fittings, the quick connect coupler on the inlet hose can be removed. The inlet hose can then be threaded directly into any female 3/8" NPT port.
3. Connect your existing high pressure hose and gun to the water heater outlet using quick connect fittings.
 - 3a. If your high pressure hose does not have quick couplers, you can order them at 1-800-270-0810.
 - 3b. If you do not want quick connect fittings, the quick connect nipple on the water heater's outlet can be removed, leaving a male 3/8" NPT fitting.
4. Fill the burner fuel tank. The tank's capacity is four gallons. We recommend kerosene because it burns cleanest. #1 grade home heating oil, #1 or #2 diesel can also be used. **DO NOT USE GASOLINE OR CRANKCASE OIL DRAINING.**
5. If detergents will be used, use only detergents intended for pressure washers. Follow instructions on the detergent container.

WARNING: Make sure that your existing hose, gun, and all accessories are rated for high temperatures and the appropriate pressure.

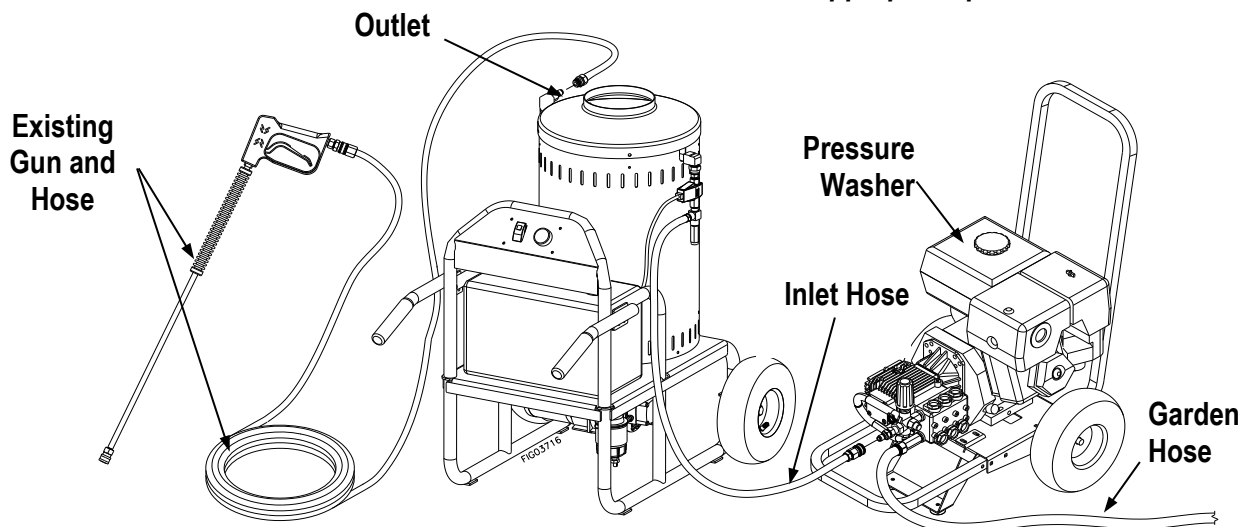

4. To Start

DANGER: Do not point the spray wand at yourself or at any person. Bodily injury may result from hot water or water under high pressure.

WARNING: Wear eye, ear, hand, foot, and skin protection at all times while operating this water heater.

1. Turn water supply ON.
2. Squeeze the trigger to allow air to purge from the system. This step goes faster with the pressure nozzle removed.

5. Turn Your Pressure Washer ON

1. Follow your pressure washer's manual for its start-up procedure.

6. Turn Water Heater ON

1. Make sure there is fuel in the fuel tank.
2. Turn the heat switch ON, and adjust the thermostat to the desired temperature.
3. The burner will fire when the trigger is squeezed. You may need to initially adjust your burner for peak performance. See the "Oil Burner" section.
4. When the trigger is released or the temp setting is reached, the burner will automatically turn off.

IMPORTANT: Do not run the machine in hot mode without any fuel in the fuel tank. The fuel pump will be damaged if it is run dry.

7. To Clean

WARNING: Wear eye, ear, hand, foot, and skin protection at all times while operating this water heater.

DANGER: Do not point the spray wand at yourself or at any person. Bodily injury may result from hot water or water under high pressure.

CAUTION: Be careful on painted or delicate surfaces. The pressure may damage the surface if the nozzle is too close.

WARNING: Only use NorthStar pressure washer chemicals or chemicals specifically formulated for pressure washers. Follow the chemical manufacturer's recommendations. Understand all safety precautions and first aid for all chemicals.

1. If your pressure washer is equipped with a quick connect chemical injector, it can be snapped onto the high pressure water outlet. Then snap the high pressure hose to the injector and submerge the suction strainer into the chemical solution.

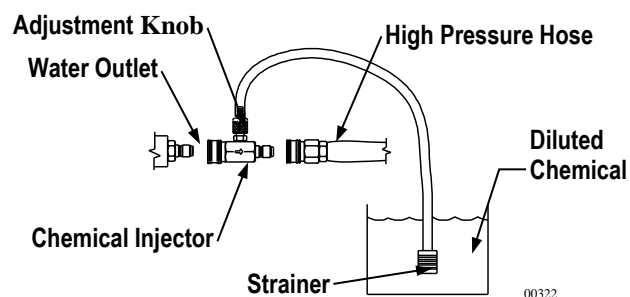

2. If your chemical injector cannot be moved to the water heater's outlet, it is acceptable to run chemicals through the heating coil. Only use NorthStar pressure washer chemicals or chemicals specifically formulated for pressure washers, and make sure that the coil is flushed completely with clean water after chemical use.
3. Spray detergent onto the surface and allow it to soak. Chemicals need time (dwell time) to work properly. Follow the chemical manufacturer's recommendations for dwell time.
4. Hold the lance with two hands. Have a sturdy stance.
5. Point lance at dirty surface and squeeze trigger.
6. Wash from the bottom to the top, using side to side motions. This washes away heavy dirt and allows the detergent to soak as you work toward the top.
7. Use the width of the spray pattern to wash in a wide path. Overlap spray paths for complete coverage.
8. The nozzle should be 12" to 24" from the work, closer for tough areas.
Caution: Be careful on painted or delicate surfaces. The pressure may damage the surface if the nozzle is too close.
9. Small parts should be washed in a basket so the pressure does not push them away. Larger, light-weight parts should be clamped down.

8. To Stop

1. If detergents were used, draw clear water through the detergent inlet line to purge detergent. Failure to do so may clog the chemical injector.
2. If the burner was used, turn *Heat Switch* to the "OFF" position and pump cold water through the coil for 3 minutes. Insufficient cool down period of high pressure hose will cause excessive wear and eventual rupturing of hose.
3. Turn the pressure washer OFF.
4. Turn OFF the water supply.
5. Squeeze the trigger to relieve the system pressure.

Maintenance & Repair

WARNING: Unauthorized machine modification or use of non-approved replacement parts may cause personal injury and/or property damage and will void the manufacturer warranty.

All mechanical equipment, no matter how well designed, will need repairs. A NorthStar water heater is no exception. At times, a NorthStar water heater may be inoperable because repairs are required. NorthStar Customer Service will assist in these repairs as needed, but if an inoperable water heater creates a major expense to your business then we strongly recommend the following:

1. Have someone on staff that is trained in the operation of the water heater and is capable of making minor repairs and performing all preventative maintenance procedures as outlined in the provided manuals.
2. Keep a stock of recommended service parts for maintenance and minor repairs.

1. Recommended Service Parts List

Following is a list of the service parts we recommend stocking.

Description	Part Number
Flow Switch	797121
Inlet Hose	780127
Electrode Kit	RWB5780U
Fuel Pump	RWB21844U
Igniter	RWB51771U
Fuel Filter Element	RCR12T
Pressure Gauge	MV32154

2. Maintenance Mode

Before performing any maintenance on the water heater, it must be placed in maintenance mode.

- A.) Turn off water supply
- B.) Bleed water from system
- C.) Turn off and unplug power cord

3. Maintenance Schedule

What to Check	When To Check	What to Do
Fuel Filter	500 hrs	Change
Tires	Each Use	Check Pressure
Hoses	Each Use	Check for Wear
Bolts	Each Use	Check for Loose Bolts

4. Checking the Tire Air Pressure

- A.) Remove air fill cap
- B.) Fill tire to 30psi (2.1 bar)
- C.) Replace air fill cap

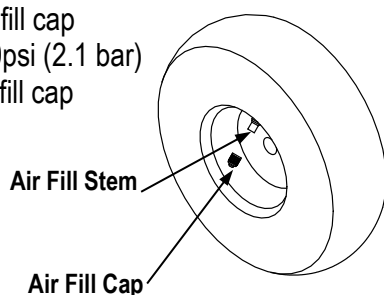

5. Burner Fuel Filter

Drain water that has accumulated in the fuel filter bowl and replace the filter as needed.

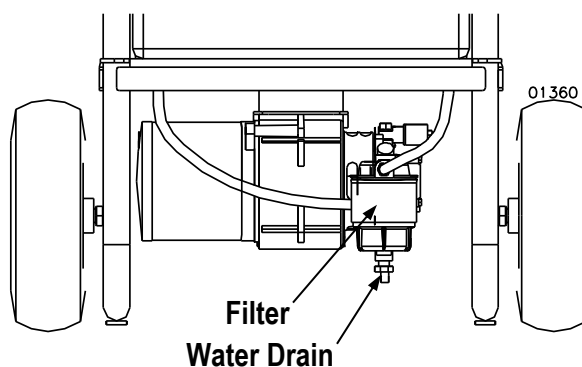

6. Checking the Hoses

WARNING: Do not use a finger or skin to check for leaks. Escaping fluid under pressure has sufficient force to penetrate the skin, causing serious injury. Do not operate the pressure washer if the hose is cracked, worn, or leaking.

- A.) Check all hoses for leaks
- B.) Check all hoses for worn areas

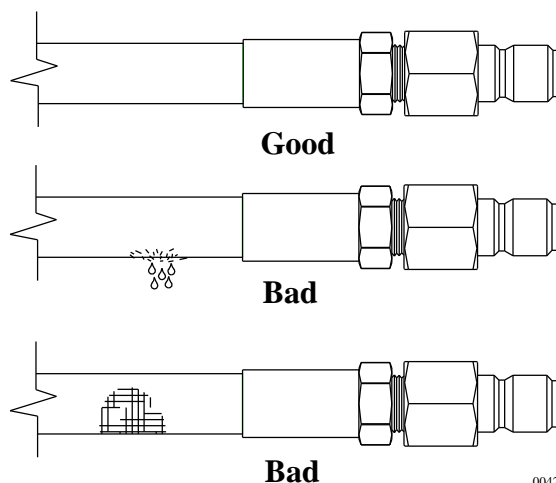

7. Coil Descaling

In hard water areas, scale build-up within the heating coil will occur. Scale deposits will decrease the water temperature rise and may eventually clog the heating coil.

1. Mix scale remover in a 5 gallon bucket and elevate the bucket so it is higher than the pump on your pressure washer.
2. Attach water heater's inlet hose to the high pressure outlet of your pressure washer.
3. Attach high pressure hose to the outlet of the water heater, but do not hook up the spray gun.
4. Place the other end of the high pressure hose in the 5 gallon bucket.
5. Attach a short length of hose to the garden hose inlet on your pressure washer.
6. Prime the pump by filling the short length of hose with water, then place the end of the hose in the 5 gallon bucket.

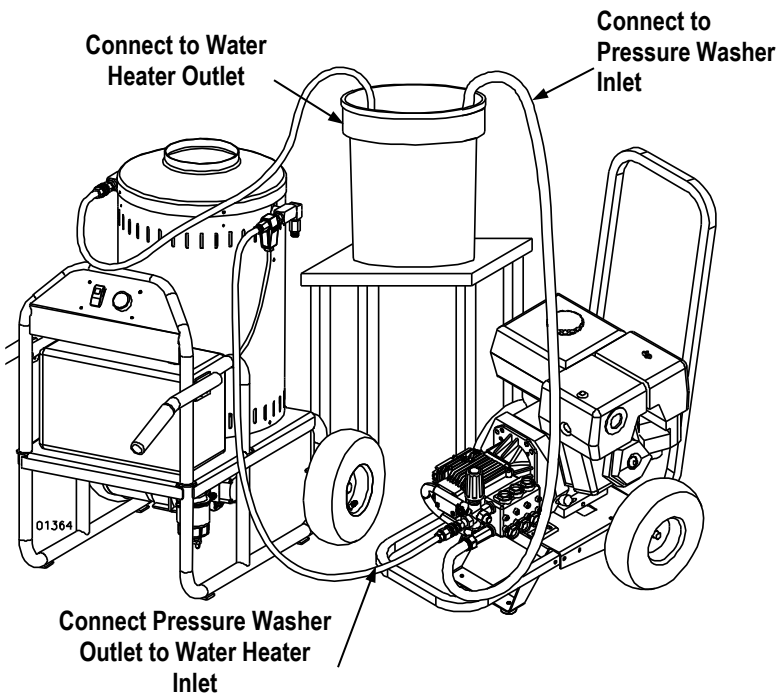

7. Run the pressure washer in cold mode for 1 to 3 hours recirculating the cleaning solution.

Warning: Do not run the burner.

8. Dispose of the cleaning solution where it is not harmful to animals or the environment.
9. Flush with fresh water and clean the inlet strainer when finished.

8. Coil Desooting

Poor grades of fuel oil or inadequate combustion air will cause heavy soot build-up on the outside surface of the heating coil. These deposits will insulate the coil. This will restrict the air flow through the coil, further aggravating the soot build-up.

Most coils will never require desooting. However, to desoot a coil:

1. Wear protective clothing, goggles, and gloves.
2. Remove the flow switch from the inlet of the heating coil and remove the thermostat from the outlet of the heating coil.
3. Remove the lid and insulation cap from the heating chamber and hoist the coil out. Be careful, the coil is very heavy.

Important: Be careful not to damage the threads on the coil inlet and outlet. If the threads get damaged, it will be hard to reconnect and seal the fittings on the coil inlet and outlet.

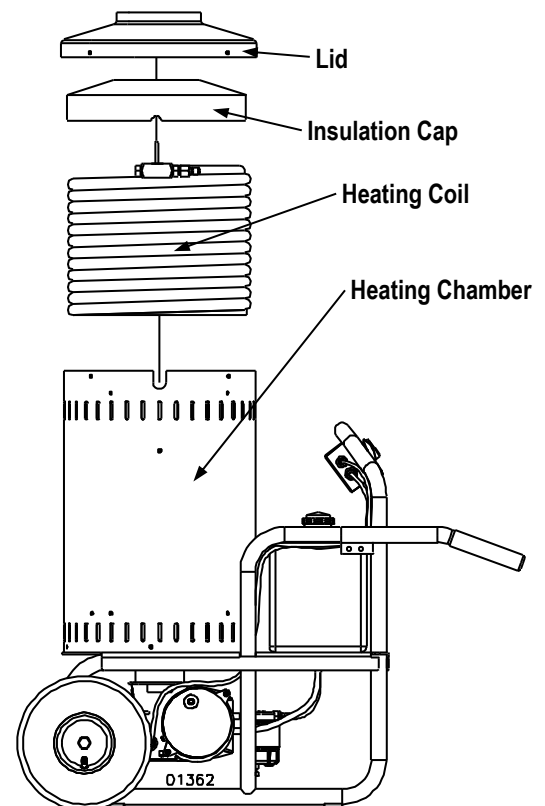

4. Clean the coil.
5. Reassemble the coil to the machine. Make sure the white insulation remains in place. Reattach the flow switch and thermostat, using thread sealant. Make sure all fittings are tight before using the machine.

9. Electrodes

On a yearly basis the electrodes should be inspected and any necessary adjustments made.

1. Block up the front of the water heater 6 inches.

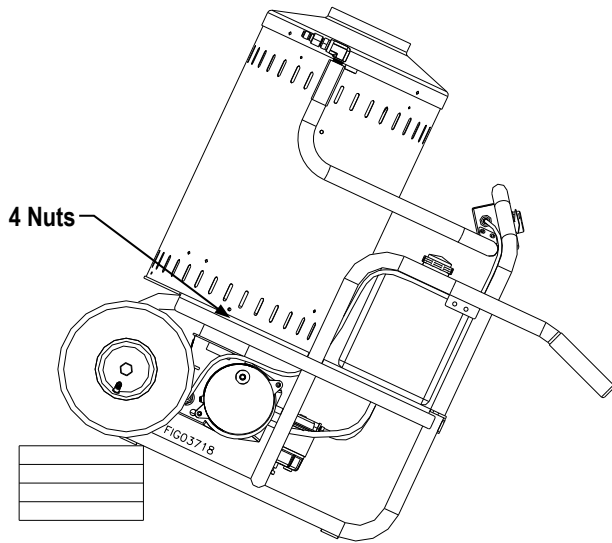

2. Remove the 4 nuts that attach the burner to the heating chamber. You do not have to disconnect the fuel lines or the electric cords, but be careful not to subject them to excessive strain. Also, make sure the fuel filter does not get damaged.
3. Let the burner fall away from the heat exchanger. Tip the burner towards you until you can see the electrodes and fuel nozzle.

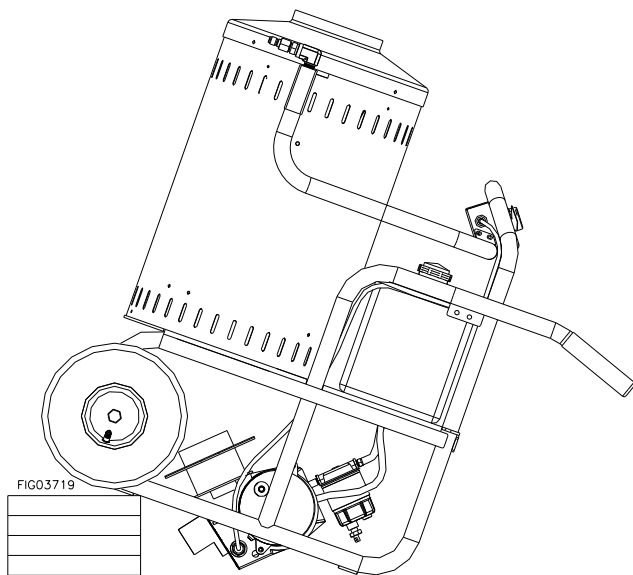

4. Clean off carbon deposits that may have accumulated on the tips of the electrodes.

5. Reset the spacing as shown below.

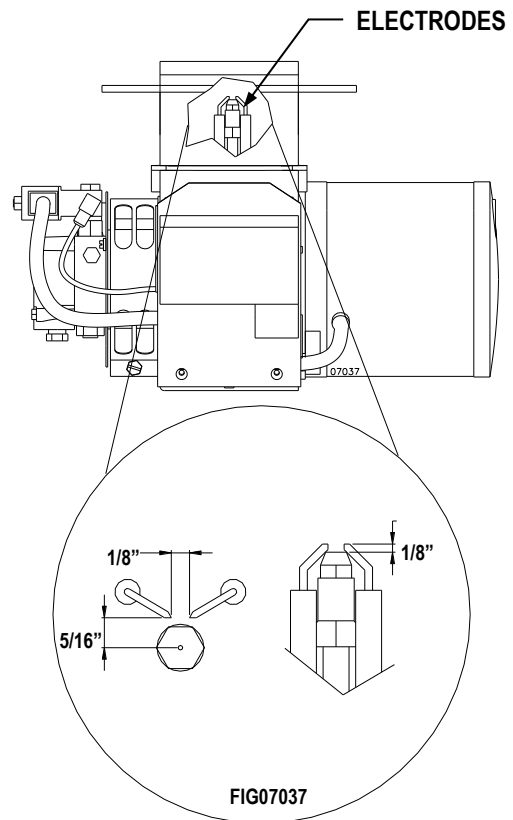

10. Flow Switch

Inspect and clean the flow switch as needed

Mineral build-up and/or debris within the flow switch can occur and may affect burner operation if not periodically cleaned. Mineral build-up and/or debris can stop the movement of the shuttle inside the flow switch body. Shuttle movement is important because the burner will not fire if the shuttle does not move. The shuttle movement actuates a switch inside the flow switch housing which allows the burner to fire during spray mode.

- 1) Disconnect the swivel fitting from elbow to the inlet of the coil

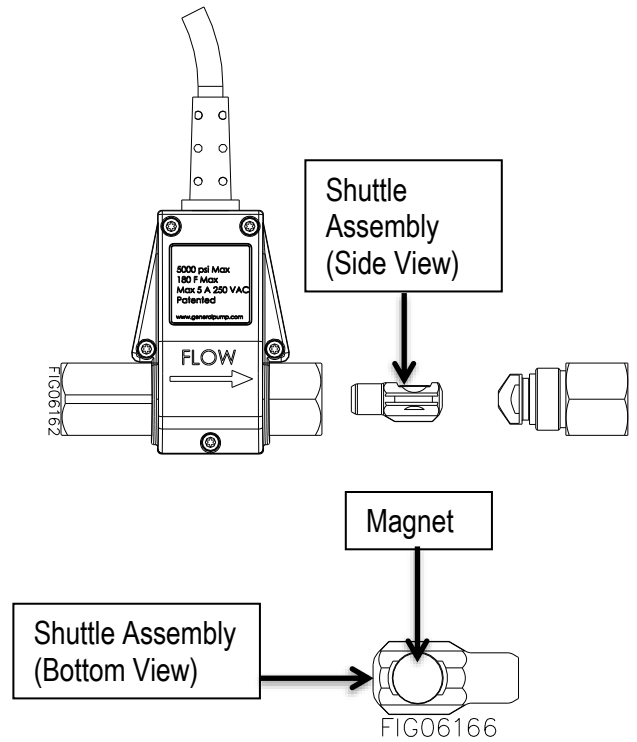
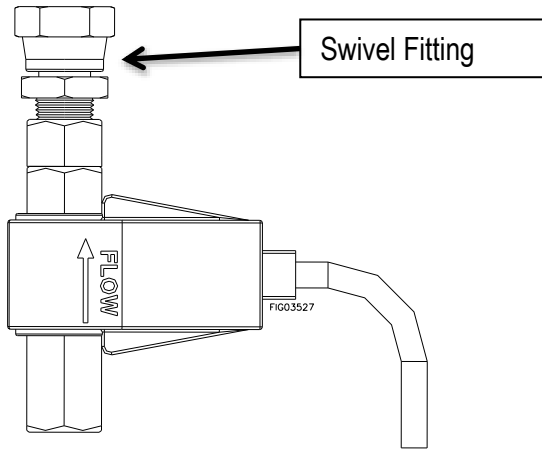

- 2) Remove the "Cap" fitting from the flow switch.

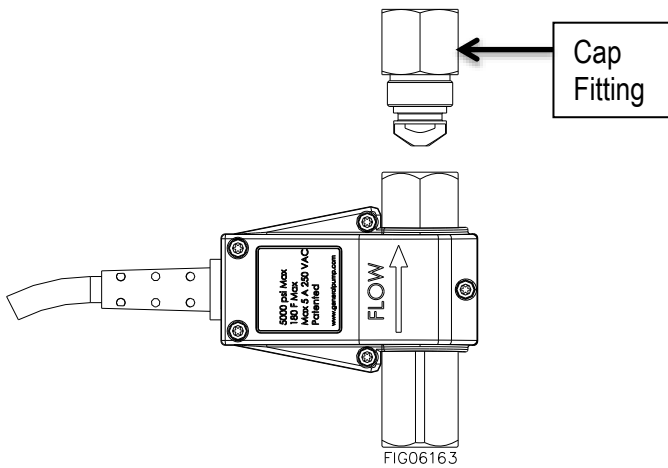

- 4) Observe the "Shuttle Assembly" and internal portion of "Body" for obstructions, hard water deposits and any other foreign debris. Remove the foreign debris with light scraping or compressed air. If no additional cleaning is required continue to Step 7. If additional cleaning is required continue to step 5.

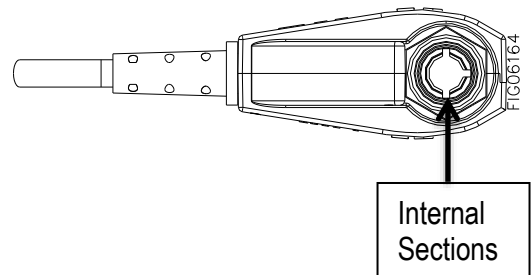

- 3) Slide out the "Shuttle Assembly". If the magnet in the shuttle assembly is damaged or missing, replace the entire flow switch assembly. To order a replacement flow switch assembly, call Northstar Product Support at **1-800-270-0810**.

- Remove the "Body" from the plastic "Enclosure" and soak the "Body" in CLR or similar solution to dislodge excess buildup. The screws (QTY 5) in the "Enclosure" are TORX T10.

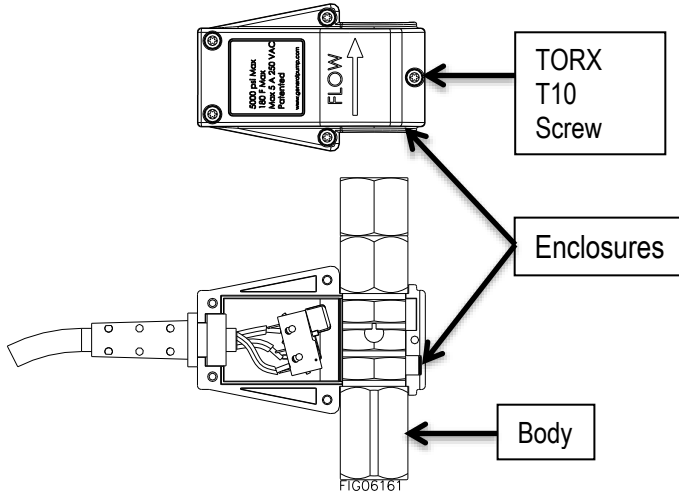

- Rinse "Body"
- When cleaning is complete reinstall the "Body" into the "Enclosures", taking care not to cause damage. Tighten the "Screws" into the body until they are snug. Do not over-tighten the screws.
- Insert the "Shuttle Assembly" with the rounded end first, into the body. Align with grooves.

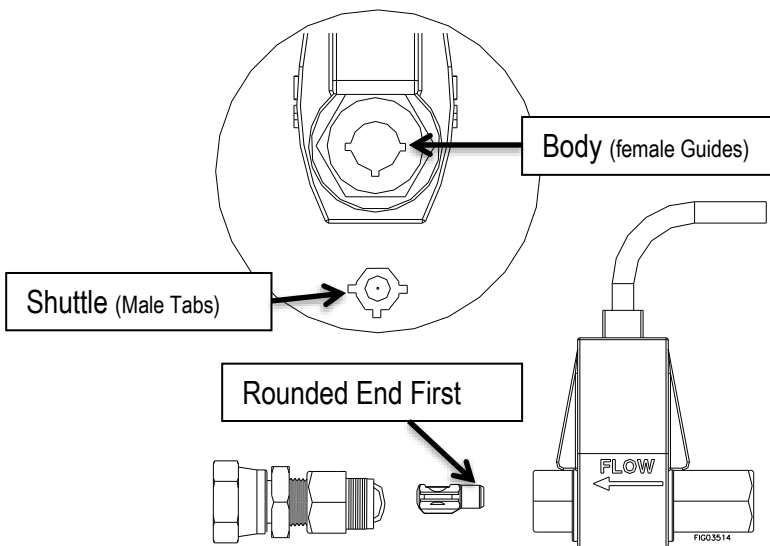

- Inspect the O-ring on the "Cap", if it is damaged, replace the entire flow switch assembly. To order a replacement flow switch assembly, call Northstar Product Support at **1-800-270-0810**. If the O-ring is not damaged, re-install the "Cap" onto the "Body". Torque the cap to 100lb-in.

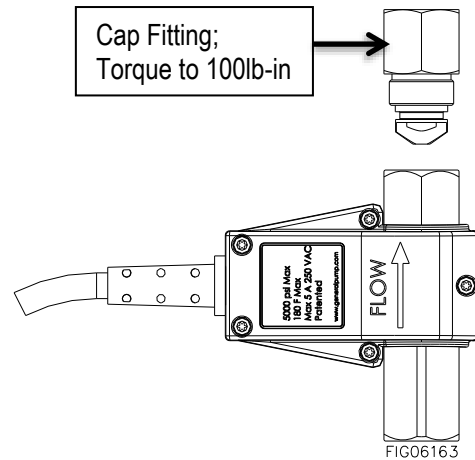

- On the elbow on the inlet of the coil, remove any remaining thread tape/sealant. Re-apply new thread tape/sealant on the elbow. Re-connect the swivel to the elbow. Hand-tighten the swivel onto the elbow, and once snug, using a wrench continue to tighten the swivel a two additional revolutions

Moving and Handling Instructions

1. Maneuvering Your Water Heater

1. Lift handles with both hands until the wheels come in contact with the ground and the frame is lifted off of the ground.
2. Push the water heater forward if it is being moved on solid, smooth ground. (concrete, hard-packed dirt)
3. Pull the water heater backward if it is being moved on rough, uneven ground. (grass, gravel)

2. Lifting Your Water Heater

1. To reduce risk of injury, it is recommended to use a hoist to lift this water heater.
2. Lift from four lifting points.
3. If the water heater is to be moved a short distance, the hoist can be positioned on the front lifting points, and the back lifting points can be hand lifted.

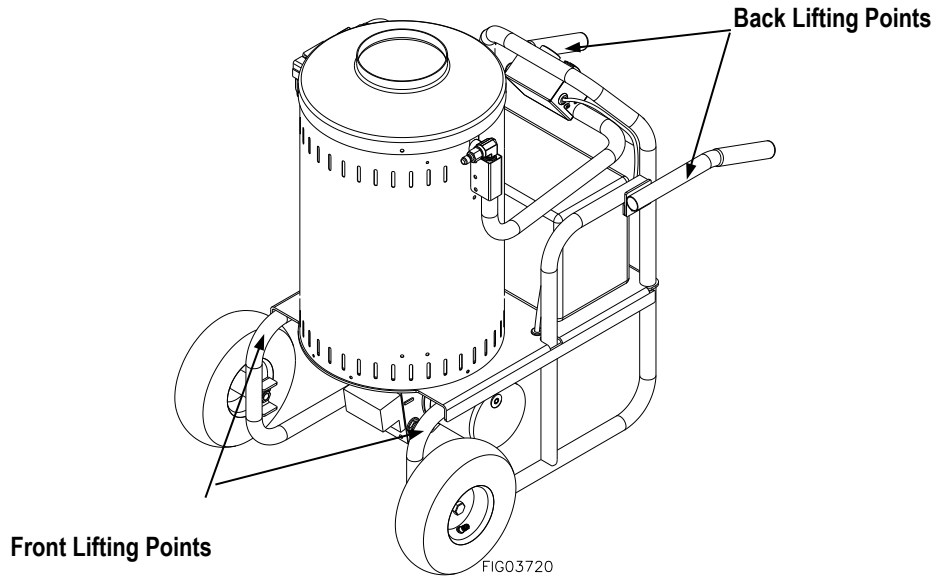

Maintenance Instructions

Winter Storage:

Items needed: 12" piece of garden hose or equivalent, funnel and RV antifreeze (approximately 2 gallons).

1. Attach the water heater's inlet hose to the high pressure outlet of your pressure washer.
2. Attach the garden hose with funnel to your pressure washer's pump inlet (see illustration).
3. Pour RV antifreeze into the funnel.
4. Turn your pressure washer on. **Do not** turn on the water heater.
5. Let your pressure washer run until antifreeze comes out of the high pressure outlet of the water heater.
6. It will take about 1.5 gallons of antifreeze to fill your pump and the heating coil.
7. Disconnect the water heater's inlet hose from the pressure washer and reconnect it to the outlet of the water heater.
8. The water heater is now prepared for long term storage.

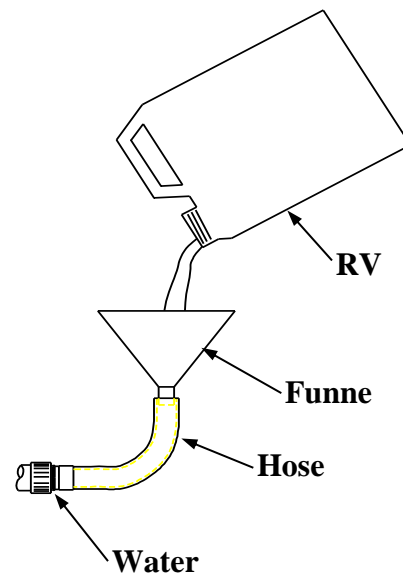

Troubleshooting Guide

Water Heater Will Not Run - No Power

Causes	Solutions
Machine not plugged in	Plug machine in.
GFCI tripped	Make sure machine is dry. Press RESET on the GFCI.
Machine turned OFF	Turn heat switch ON.
Line circuit breaker tripped	Check for tripped circuit breaker in building.

GFCI Trips During Operation

Causes	Solutions
Voltage too low	Check the voltage.
Extension Cord	Make sure connections are dry and off of the ground. Check extension cord section on page 3 for more guidelines.

Burner Will Not Fire

Causes	Solutions
Electrodes corroded or improperly spaced	Clean electrodes and reset spacing. See Electrode section on page 15.
Damaged flow switch	Replace flow switch. Call Customer Service.

Smoke From Heat Exchanger

Causes	Solutions
Air band not adjusted properly due to different elevation	Adjust the air band until the burner burns cleanly. See <i>Oil Burner</i> under <i>Installation Instructions</i> .
Poor quality fuel	Use Kerosene for the cleanest burn.

Water Not Heating Sufficiently

Causes	Solutions
Scale build-up in coil	See <i>Coil Descaling</i> under <i>Maintenance Instructions</i> .
Coil is full of soot	See <i>Coil Desooting</i> under <i>Maintenance Instructions</i> .

Rupture Disc Sprays Water

Causes	Solutions
Pressure Washer/Burner Control Problem	Call Customer Service.

Poor Or No Detergent Supply

Causes	Solutions
Soap control knob set too low.	Adjust soap control knob.
Inadequate detergent supply	Refill detergent container. Make sure chemical strainer is fully submerged.
High pressure hose too long	Use less hose. Move machine closer to the work.
Chemical strainer or injector clogged	Clean the strainer and injector. Always start with a clean detergent container. Run clean water through the injector after each use.

Any Questions, Comments, Problems or Parts Orders

NorthStar Product Support 1-800-270-0810

Parts Explosion- 157495- Rev Z

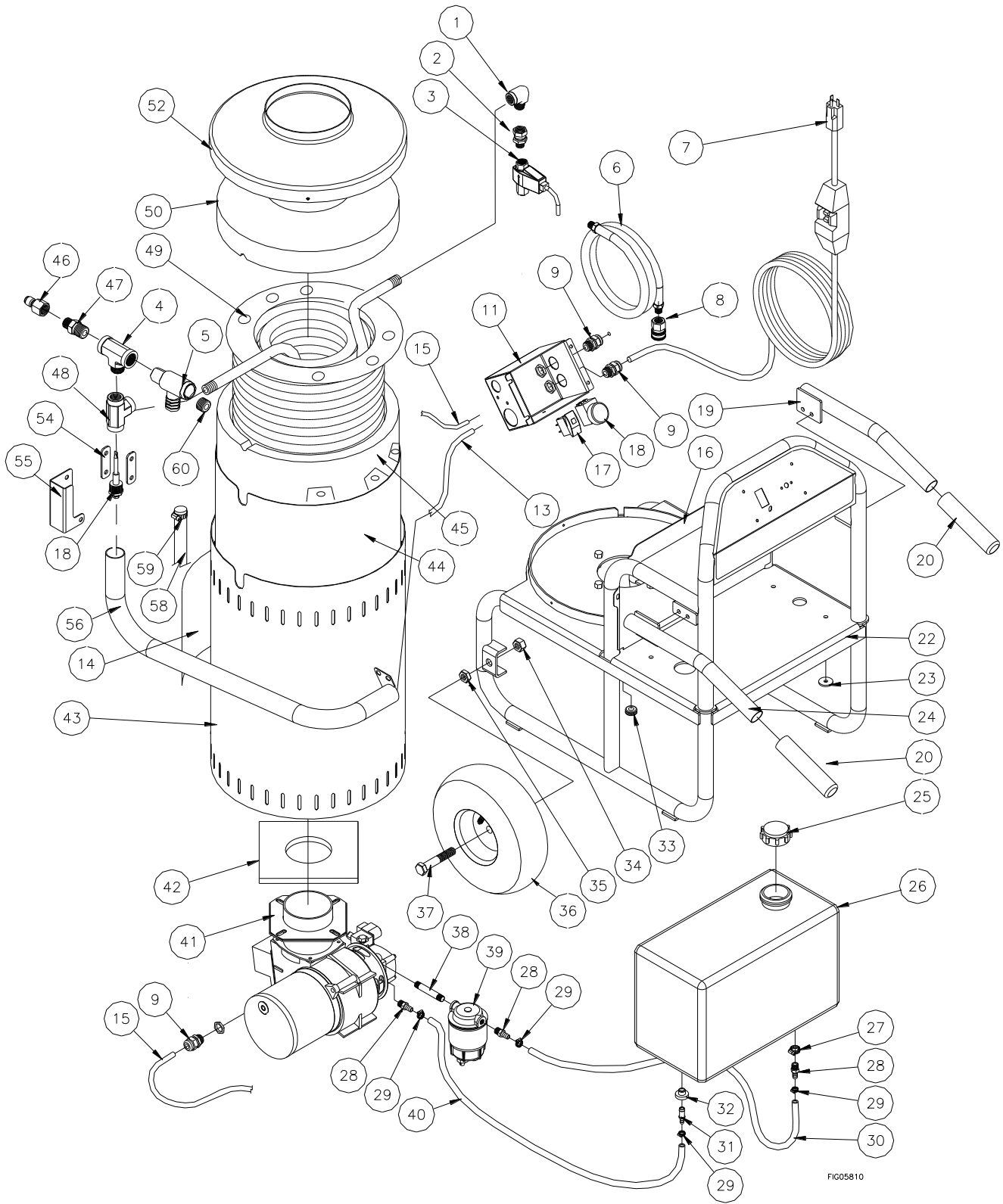
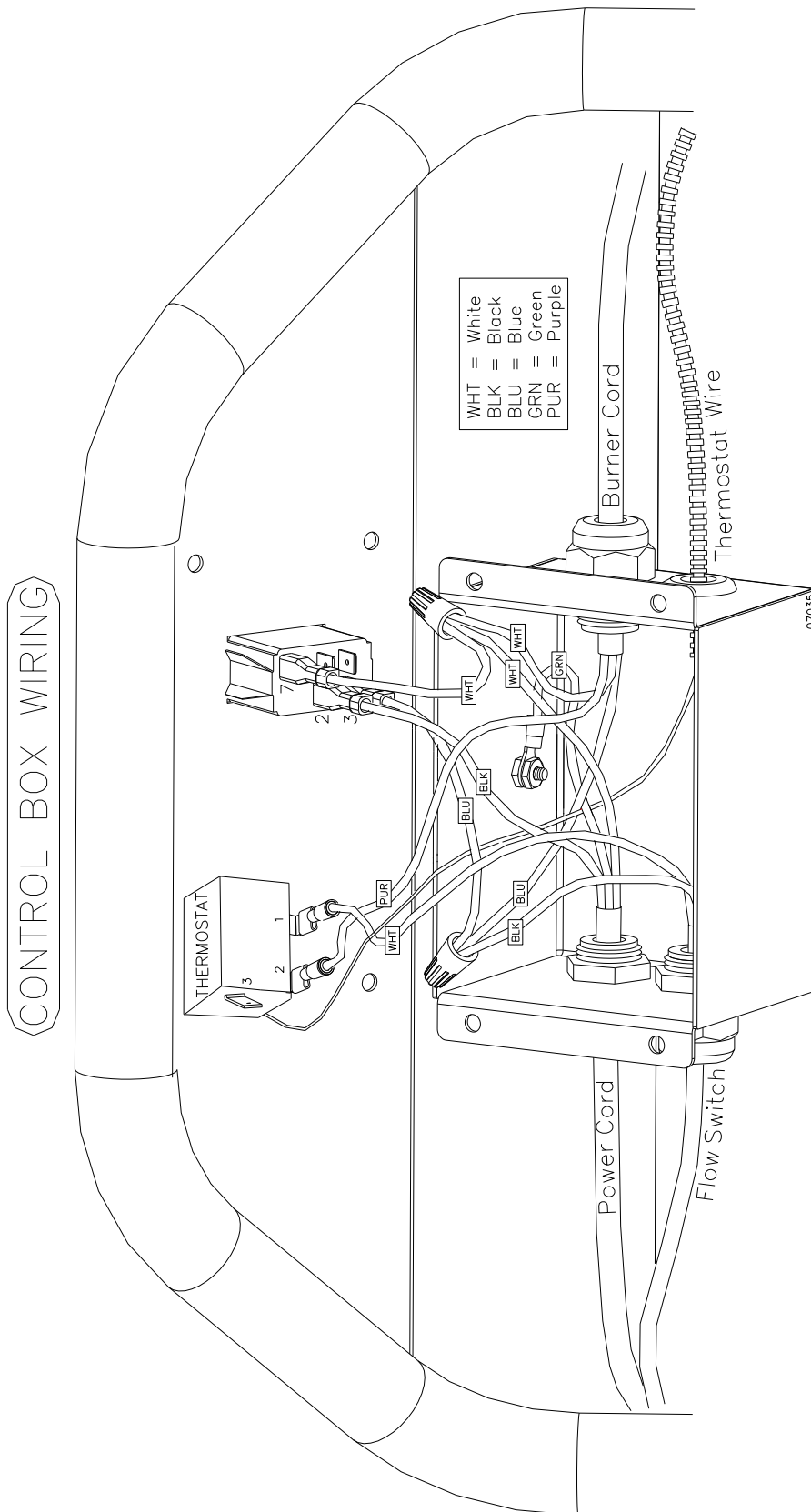

FIG05810

Parts List-157495- Rev Z

<i>ITEM</i>	<i>PART#</i>	<i>DESCRIPTION</i>	<i>QTY</i>
1	5027	1/2" NPT Steel Street Elbow	1
2	38379	1/2" FPT Swivel x 3/8" MPT Straight	1
3	797121	Flow Switch	1
4	787394	1/2" Tee, FFXM, Steel	1
5	794626	Rupture Disc-8500, Kit	1
6	780127	High Pressure Inlet Hose, 3/8" X 5'	1
7	804113	Power Cord w/ GFCI, 15A, 115V Self Test	1
8	777914	3/8" Quick Coupler, Female	1
9	22502	Strain Relief, 1/2" NPT	4
11	801075	Control Box	1
13	30501	1/4" Split Loom	27"
14	787751	Decal Sheet, NorthStar Branding	1
15	803769	Burner Cord	1
16	38482	Heat Shield	1
17	305180	Switch, 120V Lamp	1
18	790561	Adjustable Thermostat	1
19	37525	Right Handle	1
20	30747	Handle Grip	2
22	801077	Frame	1
23	30754	Leather Washer	4
24	37524	Left Handle	1
25	KEL204846	Fuel Cap	1
26	777727	Fuel Tank, 4 Gallon	1
27	777119	Hose Clamp, 1/2"	1
28	777340	1/4" NPT x 1/4" Hose Barb	3
29	17141	Hose Clamp, 1/4"	4
30	801490	Fuel Line 1/4" Hose, Inlet	8.5"
31	31976	1/4" Fuel Tank Fitting	1
32	306401	Rubber Seal, Fuel Tank	1
33	777111	Large Grommet	1
34	82125	5/8-11 Hex Nut	2
35	82126	5/8-11 Hex Jam Nut	2
36	789074	Pneumatic Wheel, 10"	2
37	82123	5/8-11 X 3.5" Hex Bolt	2
38	305239	1/4" NPT Nipple 3" Long	1
39	799864	Filter Fuel/Water Separator	1
40	801490	Fuel Line Hose 1/4" , Bypass	18.5"
41	804307	Burner	1
42	38120	Insulation Gasket	1
43	790040	Vented Wrap	1
44	779232	Fire Chamber	1
45	33387	Insulation Can	1
46	777915	3/8" Nipple, Quick Connect	1
47	777337	1/2" NPT x 3/8" NPT Nipple	1
48	305208	1/2" Tee, Plated Steel	1
49	790017	Heating Coil	1
50	38398	Insulation Cap	1
52	35331	Lid, Heat Exchanger	1
54	785928	Thermostat guard tab	2
55	785936	Thermostat guard plate	1
56	785938	Thermostat tube	1
58	793836	3/4" Hose	1
59	17141	3/4" Hose Clamp	2
60	30511	1/2" NPT Hex Plug	1

Wiring Diagrams



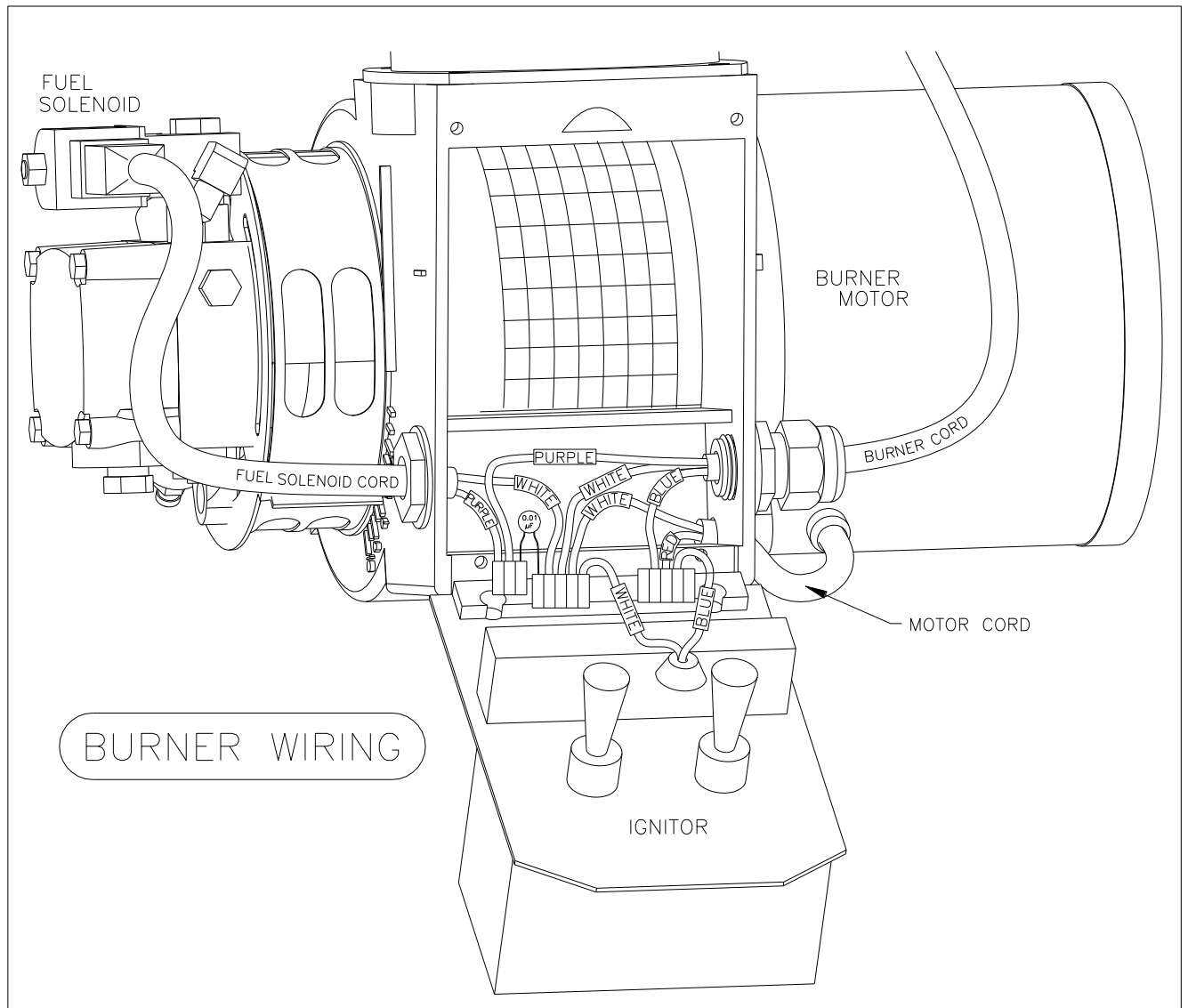

ELECTRICAL DIAGRAM

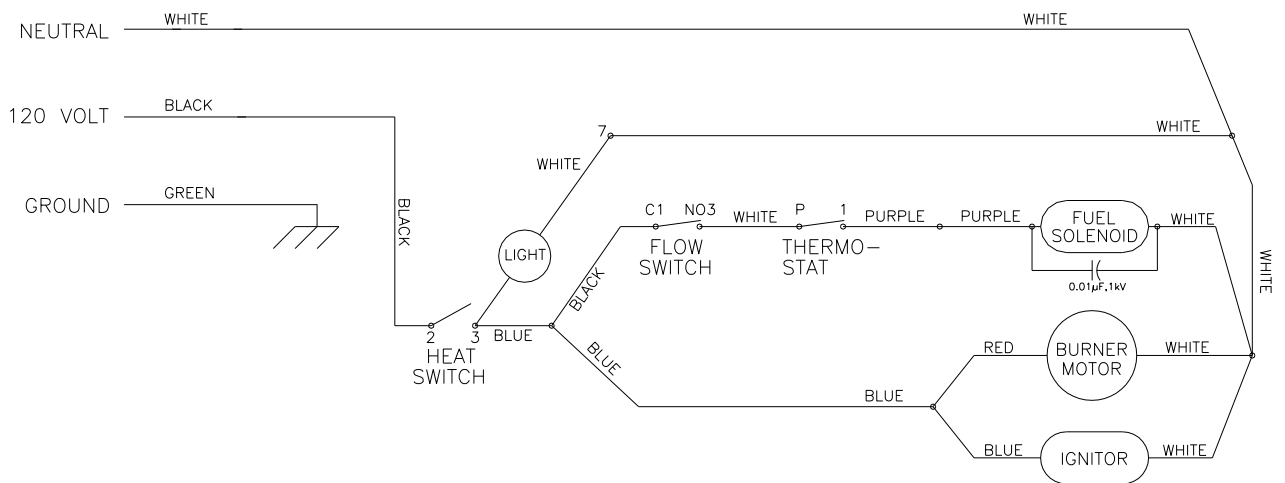

fig07050

Limited Warranty

Dear Valued Customer:

The NorthStar Product you just purchased is built with the finest material and craftsmanship. Use this product properly and enjoy the benefits from its high performance. By purchasing a NorthStar product, you show a desire for quality and durability. Like all mechanical equipment this unit requires a due amount of care. Treat this unit like the high quality piece of machinery it is. Neglect and improper handling may impair its performance. Please thoroughly read the instructions and understand the operation before using your product. Always contact NorthStar Product Support at 1-800-270-0810 prior to having any service or warranty work performed, as some services performed by parties other than NorthStar approved service centers may void this warranty. This warranty is in lieu of any other warranty expressed or implied and NorthStar assumes no other responsibility or liability outside that expressed within this warranty.

Limited Warranty

NorthStar shall warranty any piece of equipment manufactured, or parts of equipment manufactured, to be free from defects in material or workmanship for a period of:

NorthStar Warranty		
Item #	Consumer Warranty Period	Commercial Warranty Period
157495	2 years from date of purchase by user	2 years from date of purchase by user

“Consumer use” means personal residential household use by a consumer. “Commercial use” means all other uses, including use for commercial, income producing or rental purposes or when purchased by a business.

This warranty applies to the original purchaser of the equipment (verification of purchase, in the form of a receipt, is the responsibility of the buyer), is non-transferable, and covers parts and labor. Parts will be replaced or repaired at no charge, except when the equipment has failed due to lack of proper maintenance. If a part is no longer available, the part may be replaced with a similar part of equal function. Any misuse, abuse, alteration or improper installation or operations will void warranty. Determining whether a part is to be replaced or repaired is the sole decision of NorthStar. NorthStar will not provide for replacement of complete products due to defective parts. Any costs incurred due to replacement or repair of items outside of a NorthStar approved facility is the responsibility of the buyer and not covered under warranty. Transportation costs to and from service center is the responsibility of the customer.

In addition to the normal warranty, NorthStar shall warrant any normal wear item from defects in material or workmanship for a period of 90 days from the date of purchase by user. Normal wear items include, but are not limited to, nozzles, quick connect fittings, valves, high and low pressure water seals/packing, high and low pressure hoses, O-rings, unloader valves and filter elements.

This warranty specifically excludes the following; failure of parts due to damage caused by accident, fire, flood, windstorm, acts of God, applications not approved by NorthStar in writing, corrosion caused by chemicals, use of replacement parts which do not conform to manufacturer’s specifications, damage related to the use of biodiesel fuel, damage related to rodent and/or insect infestation and damage caused by vandalism. Additional exclusions: loss of running time, inconvenience, loss of income, or loss of use, including any implied warranty of merchantability of fitness for a specific use. Also, Outdoor Power Equipment needs periodic parts and service to perform well, and this warranty does not cover instances when normal use has exhausted the life of a component or the engine.

This warranty does not cover any personal injury or damage to surrounding property caused by failure of any part. Repair or replacement of parts does not extend the warranty period.

Normal burner maintenance such as cleaning and adjusting electrodes, descaling the coil, desooting the coil, air adjustments, fuel system cleaning and obstruction due to build up is not covered by this NorthStar warranty.

Please fill in the following information and have it on hand when you call in on a warranty claim.

Customer Number: _____

Date of Purchase: _____

NorthStar Serial Number: _____

Item Number: _____

▲WARNING: This product can expose you to chemicals including gasoline engine exhaust, which is known to the State of California to cause cancer, and carbon monoxide, which is known to the State of California to cause birth defects or other reproductive harm.

For more information go to www.P65Warnings.ca.gov.



Manufactured by
Northern Tool + Equipment Co., Ltd
Burnsville, MN 55306
NorthernTool.com