



POWERHORSE[®]

Truck Loader Vac

Owner's Manual



⚠ WARNING: Read carefully and understand all ASSEMBLY AND OPERATION INSTRUCTIONS before operating. Failure to follow the safety rules and other basic safety precautions may result in serious personal injury.

Item #110095

READ & SAVE THESE INSTRUCTIONS

Thank you very much for choosing a Powerhorse™ product!

For future reference, please complete the owner's record below:

Serial Number/Lot Date Code: _____

Purchase Date: _____

Save the receipt, warranty, and this manual. It is important that you read the entire manual to become familiar with this product before you begin using it.

This truck loader vac is designed for certain applications only. Northern Tool and Equipment is not responsible for issues arising from modification or improper use of this product such as an application for which it was not designed. We strongly recommend that this product not be modified and/or used for any application other than that for which it was designed.

For technical questions, please call **1-800-222-5381**.

Table of Contents

Intended Use.....	4
Packaging Contents.....	4
Technical Specifications	4
Important Safety Information	5
Specific Operation Warnings	7
Safety Labels	9
Main Parts of Truck Loader Vac	11
Parts List.....	12
Assembly Instructions.....	13
Before Each Use.....	17
Operating Instructions.....	18
After Each Use.....	20
Maintenance	22
Troubleshooting.....	22
Parts Diagram.....	24
Parts List.....	24
Replacement Parts	25
Limited Warranty.....	26

Intended Use

The Powerhorse Truck Loader Vac is intended for vacuuming leaves, clippings, and other similar sized organic material from the ground into a truck or trailer.

Packaging Contents

- Nozzle
- Hose Clamps (2)
- Boom Mast
- House Cover
- Chains (2)
- Direction Plate
- Engine Bases (2)
- End Cap
- Handles (2)
- Hose Cover
- Stopper
- Hose Band
- Hand Wheels (5)
- Discharge Liner
- Base Plates (2)
- Knife
- Hose
- Boom Arm
- Impeller
- Housing
- Discharge Chute
- End Caps (4)
- Hose Adapter
- Cover

Technical Specifications

Property	Specification
Engine Brand	Ducar
Engine Type	OHV
Displacement	212CC
Starting	Pull
RPM	3600
Fuel Capacity	0.7Gal
Oil Capacity	0.16Gal
Oil Type	SAE 30W
Vacuum Hose	6" x 10'
Mounting Requirements	2" Square Class III or Class IV: Swing Away Hitch Mount Tailgate Mount
Shipping Dimension (inches)	37.8 x 26 x 37.4
Assembled Dimension (inches)	25.6 x 19.1 x 55.1
N.W. (lb.)	132

Important Safety Information

⚠️WARNING

- Read and understand all instructions. Failure to follow all instructions may result in serious injury or property damage.
- The warnings, cautions, and instructions in this manual cannot cover all possible conditions or situations that could occur. Exercise common sense and caution when using this tool. Always be aware of the environment and ensure that the tool is used in a safe and responsible manner.
- Do not allow persons to operate or assemble the product until they have read this manual and have developed a thorough understanding of how it works.
- Do not modify this product in any way. Unauthorized modification may impair the function and/or safety and could affect the life of the product. There are specific applications for which the product was designed.
- Use the right tool for the job. DO NOT attempt to force small equipment to do the work of larger industrial equipment. There are certain applications for which this equipment was designed. This product will be safer and do a better job at the capacity for which it was intended. DO NOT use this equipment for a purpose for which it was not intended.
- Industrial or commercial applications must follow OSHA requirements.

⚠️WARNING

WORK AREA SAFETY

- Inspect the work area before each use. Keep work area clean, dry, free of clutter, and well-lit. Cluttered, wet, or dark work areas can result in injury. Using the product in confined work areas may put you dangerously close to cutting tools and rotating parts.
- Do not use the product where there is a risk of causing a fire or an explosion; e.g., in the presence of flammable liquids, gases, or dust. The product can create sparks, which may ignite the flammable liquids, gases, or dust.
- Keep children and bystanders 20 ft from the work area while operating the tool. Do not allow children to handle the product.
- This machine is to be operated by one person only. When operating the machine, only stand in the operator feed area.
- Be aware of all power lines, electrical circuits, water pipes, and other mechanical hazards in your work area. Some of these hazards may be hidden from your view and may cause personal injury and/or property damage if contacted.
- Do not tilt or transport the machine while it is operating. Only operate this machine in open space (e.g. not close to a wall or other fixed object) on a flat, level surface away from.

⚠️WARNING

PERSONAL SAFETY

- Stay alert, watch what you are doing, and use common sense when operating the tool. Do not use the tool while you are tired or under the influence of drugs, alcohol, or medication. A moment of inattention while operating the tool may result in serious personal injury.
- Dress properly. Do not wear loose clothing, dangling objects, or jewelry. Keep your hair, clothing and gloves away from moving parts. Loose clothes, jewelry, or long hair can be caught in moving parts. Air vents on the tool often cover moving parts and should be avoided.
- Keep hands and feet away from inlet and discharge openings.
- Avoid burns from engine by not touching hot exhaust.
- Check that the split housing is fastened shut.
- Wear the proper personal protective equipment when necessary. Use ANSI Z87.1 compliant safety goggles (not safety glasses) with side shields, or when needed, a face shield. Use a dust mask in dusty work conditions. Also use non-skid safety shoes, hardhat, gloves, dust collection systems, and hearing protection when appropriate. This applies to all persons in the work area.
- Do not overreach. Keep proper footing and balance at all times. Never stand at a higher level than the base of the machine when feeding material into it. Ensure that there are no tripping hazards in the feed area.
- Carbon Monoxide Warning. The running engine gives off carbon monoxide, a poisonous gas that can kill you. You CANNOT smell it, see it, or taste it. If you start to feel sick, dizzy, or weak while using the chipper, shut off the engine and get to fresh air immediately. See a doctor. You may have carbon monoxide poisoning.

⚠️WARNING

OPERATIONAL SAFETY

- Make sure that the machine is properly adjusted, set up correctly and the hose is empty before starting the machine.
- Never leave the machine running unattended. Always turn off the engine, wait for the impeller to come to a complete stop, and disconnect the spark plug before leaving the area. Always move the unit to a safe storage area when not in use.
- Do not feed metal, rocks, bottles, cans or any other non-botanical objects into the machine. Inspect wood for nails or other foreign objects.
- Make sure the machine has come to a complete stop and disconnect the spark plug wire before freeing a jam or clog, emptying the bag, filling the gas tank, or performing any maintenance or repairs.
- Never direct discharge material toward anyone. Avoid discharging material against a wall or obstruction. Material may ricochet back toward the operator.
- Never attempt to reposition or move the debris loader unit while it is running. Doing so could cause the machine to tip over and cause unexpected injury.

⚠CAUTION

TRUCK LOADER VAC USE AND CARE

- Do not force the truck loader vac. Products are safer and do a better job when used in the manner for which they are designed. Plan your work, and use the correct product for the job.
- Check for damaged parts before each use. Carefully check that the product will operate properly and perform its intended function. Replace damaged or worn parts immediately. Never operate the product with a damaged part.
- Do not use a product with a malfunctioning switch. Any power tool that cannot be controlled with the power switch is dangerous and must be repaired by an authorized service representative before using.
- Disconnect the power/air supply from the product and place the switch in the locked or off position before making any adjustments, changing accessories, or storing the tool. Such preventive safety measures reduce the risk of starting the tool accidentally.
- Store the product when it is not in use. Store it in a dry, secure place out of the reach of children. Inspect the tool for good working condition prior to storage and before re-use.
- Use only accessories that are recommended by the manufacturer for use with your product. Accessories that may be suitable for one product may create a risk of injury when used with another tool. Never use an accessory that has a lower operating speed or operating pressure than the tool itself.
- Keep guards in place and in working order. Never operate the product without the guards in place.
- Do not leave the tool running unattended.

Specific Operation Warnings

⚠WARNING

- **READ THIS ENTIRE MANUAL AND MOTOR MANUAL:** These manuals contain proper operating and safety instructions for this chipper/ shredder.
- **SAFETY EQUIPMENT:** Wear safety glasses, hearing protection, and gloves when operating a Chipper Shredder. Make sure any bystanders are also wearing safety equipment.
- **ENGINE OPERATION:** Refer to the engine manual for operating instructions and gasoline engine safety warnings.
- **HAND SAFETY:** DO NOT put hands or other body parts into the inlet or outlet while the blades are turning. The truck loader can drag you into the blade, causing amputation of fingers, hands or other body parts. DO NOT touch the exhaust during or immediately after operation to prevent burns.
- **CLOTHING:** DO NOT wear loose clothing, neckties, scarves, or jewelry which may get caught in moving parts. DO NOT wear clothing or gloves with pull ties or straps. This type of clothing could get tangled with material that is being shredded, pulling you into the truck loader.
- **OPERATING LOCATION:** Set up the truck loader on a firm, level, grass or dirt. DO NOT set up the truck loader on gravel, asphalt, concrete, or stone. The chips are expelled from the machine

with enough force to ricochet off hard surfaces and cause serious injury. DO NOT set up the truck loader in a location where sparks or heat from the motor could cause a fire.

- **JAMS AND CLOGGING:** Turn the truck loader OFF, allow all moving parts to come to a complete stop, and disconnect the spark plug wire before attempting to free a jam or clog.
- **TURN OFF TRUCK LOADER:** Turn OFF the machine, allow all moving parts to come to a complete stop, and disconnect the spark plug wire before moving the machine, emptying the bag, unclogging the inlets or outlets, filling the gas tank, or performing maintenance and repairs.
- **STARTING THE TRUCK LOADER:** Make sure hands and feet are clear of the intake hose. Make sure the inlet is empty when starting the machine. The pull start cord may stop suddenly causing the truck loader to fall over or injure your hand or arm.
- **CLEANING TRUCK LOADER:** Allow the motor to cool off, then brush dust and chip build-up off of the motor to prevent fire or motor overheating.

Safety Labels

⚠ DANGER



Amputation Hazard

High speed cutting blade! To prevent serious injury, keep hands out of the discharge area when it is running.

⚠ WARNING

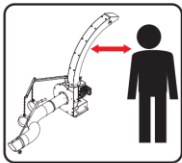

⚠ DANGER



⚠ WARNING



Read carefully and understand all INSTRUCTIONS before operating. Failure to follow the safety rules and other basic safety precautions may result in serious personal injury.

⚠ WARNING

Engine is shipped from factory without oil. You must add engine oil before starting engine.

⚠ WARNING

- To prevent serious injury or property damage, read and understand owner's manual before operating.
- Always wear the proper protective equipment including ANSI Z87.1 compliant eye protection.
- Keep hands and other body parts away from intake impeller and discharge chute.
- Keep bystanders away from the work area while operating.
- Do not run or operate the machine when mounting or dismounting from the swing-away.
- Close and lock the swing-away when mounting or dismounting it.
- Do not run or operate the machine when changing the position of the swing-away.
- When rotating the swing-away, make sure the area is clear to complete the movement.

⚠ DANGER



Amputation Hazard

High speed cutting blade!
To prevent serious injury, keep hands out of the intake area when it is running. Turn engine off and wait for blade to come to a complete stop before removing hose or making adjustments.

⚠ WARNING

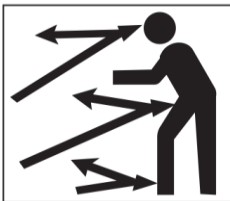

Discharge Objects Hazard

• To prevent serious injury from discharge debris, wear ANSI Z87.1 compliant eye protection and install a discharge bag before operating • The operator should not stand in front of the discharge chute while the machine is running • Keep bystanders at least 20 ft away from work area while the machine is running

⚠ DANGER



DO NOT open unless the machine has come to a complete stop and the spark plug wire has been disconnected.

Make sure this cover is in place before starting the machine.

Main Parts of Truck Loader Vac

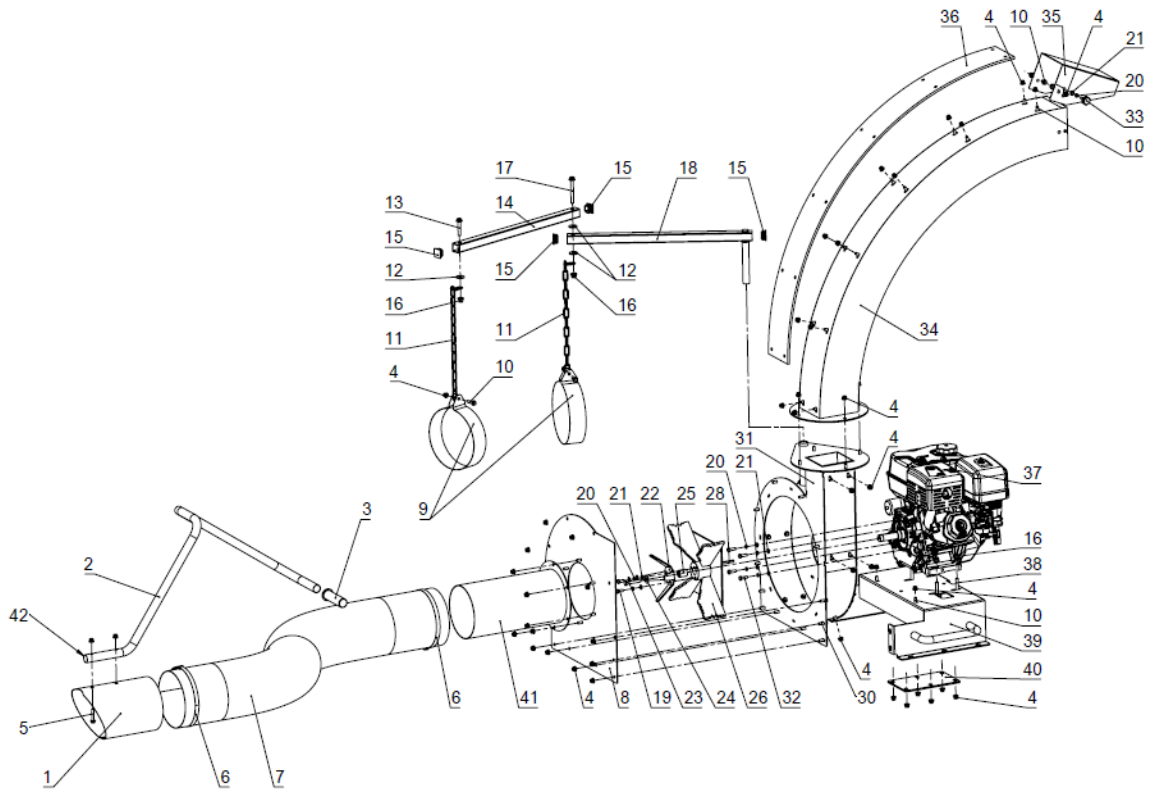

Parts List

Part No.	Description	Quantity	Part No.	Description	Quantity
1	Nozzle	1	23	Bolt	1
2	Handle	2	24	Spring Washer	1
3	Handle Sleeve	2	25	Stopper	1
4	Screw Nut M8	40	26	Impeller	1
5	Bolt M8x40	2	27	Screw	2
6	Hose Clamp	2	28	Engine Flat Key	1
7	Hose	1	29	Bearing Sleeve	1
8	House Cover	1	30	Bolt M8x25	4
9	Hose Band	2	31	Housing	1
10	Bolt M8x20	33	32	Bolt	4
11	Chain	2	33	Hand Wheel	5
12	Washer	4	34	Discharge Chute	1
13	Bolt M10x55	1	35	Direction Plate	1
14	Boom Arm	1	36	Discharge Liner	1
15	End Cap	4	37	Engine	1
16	Screw nut M10	6	38	Bolt M10x40	1
17	Bolt M10 x 90	1	39	Engine Base	1
18	Boom Mast	1	40	Base Plate	2
19	Bolt M8x25	3	41	Hose Adapter	1
20	Spring Washer	12	42	End Cap	1
21	Flat Washer	12			
22	Knife	1			

Accessory Options

Part #63686: 2 Inch Receiver Hitch Mount



Part #63687: 2 Inch Tailgate Mount



Part #63688: 2 Inch Swing-away Hitch Mount



Assembly Instructions

Remove unit from crate. The truck loader vac can be mounted in four ways. The frame mounting will be covered below. Refer to the manual supplied with each accessory.

- Fill the engine with oil. Fill the fuel tank with clean, fresh gasoline.
- Assemble the discharge chute.
- Slide the flange clamp plate over discharge chute.
- Position the discharge flange over the fan housing flange.
- Position the flange clamp plate over the fan housing studs and secure with two 3/8-16 insert flange nuts and two locking knobs. Back the nuts off from tight just enough so the chute may be turned for positioning.
- Lock the chute in the desired position by tightening the knobs.
- Assemble the boom assembly in the receiver tube on top of the fan housing.
- Connect the hose to the inlet flange.
- Insert the adaptor; turn to lock, and secure in place with the locking knobs.

- Read the owner's manual before operating the machine.

Unit Mounting and Mounting Accessories

Most truck loader vac installations are customized and somewhat unique. It is the responsibility of the installer to ensure the installation is sufficient to carry the truck loader vac and/or accessories.

The truck loader vac can be mounted in four different ways. Brief instructions for each are listed below. Refer to the specific mounting accessory and owner's manual for detailed instructions.

Mounting the Truck Loader Vac

Mount the Truck Loader Vac frame to the frame or swing away, and secure frame with six 3/8" hex head bolts, 3/8" flat washers, and 3/8" lock nuts. See figure 1.

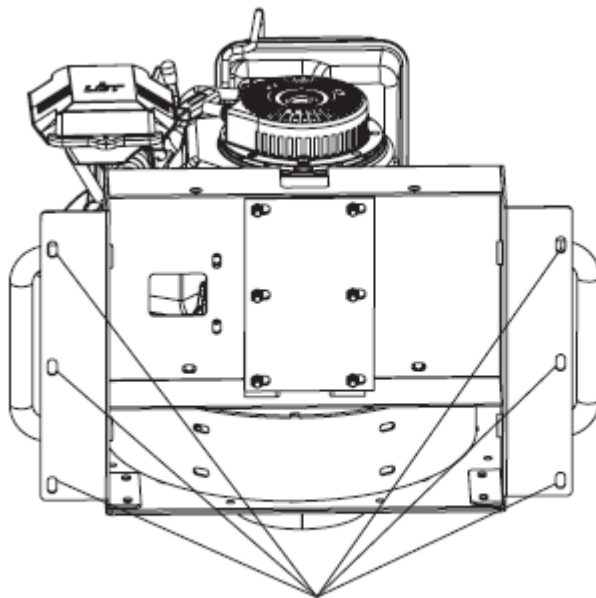

figure 1

Mounting hoses for the 3/8" hex head bolts

Hitch Mount (#63686)

Vehicle Requirement: Vehicle with 2" square Class III or Class IV hitch receiver.

Application: Inexpensive mount on either a fixed or tilted bed truck. Must be removed to tilt bed or unload. Install the hitch bar in the channel underneath the debris loader unit. Secure the hitch bar from pulling out with the hitch pin and hairpin cotter provided. Sandwich the hitch bar between the unit and the clamp plate: Secure the clamp plate with six (6) 3/8-16X1 bolts and six (6) 3/8-16 nylon insert flange nuts.

To mount the unit on a truck get a helper and pick up the unit. Use proper lifting technique. Slide the hitch bar into the vehicle's hitch receiver. Secure with the hitch pin and hairpin cotter. Attach the safety chains to the vehicle.

To remove the unit, remove the hose/boom assembly and disconnect the safety chains and hitch pin.

With a helper, lift and slide the unit out of the vehicle hitch receiver and set it down.

Tailgate Mount (#63687)

Vehicle Requirement: A suitable heavy duty tailgate like those used on dump bodies or a similar structure. A pickup tailgate will not handle this mount.

Application: Fixed or tilt bed. Must be removed to tilt or unload. Keeps hitch receiver free so a trailer may be pulled.

- Install tailgate mount on the tailgate of your truck. Adjust the clamps to grip the tail gate securely when the lever handle is pulled down and locked. If the adjusting nuts do not provide sufficient travel, the clamp pads may be moved to a different set of holes to get a secure fit.
- Remove the mount from the tailgate and install the hitch bar in the channel underneath the debris loader unit.
- Secure the hitch bar from pulling out with the hitch pin and hairpin cotter provided. Sandwich the hitch bar between the unit and the clamp plate.
- Secure the clamp plate with six (6) 3/8-16x1 bolts and six (6) 3/8-16 nylon insert flange nuts.
- To mount the unit on a truck get a helper and pick up the assembly and lift it over the tailgate. Use proper lifting technique. Pull the clamp levers down and secure them in place with the locks.
- To remove the unit, remove the hose/boom assembly, unlock the clamp levers and open the clamps. With a helper, lift the unit over the vehicle tail gate and set down. Use proper lifting technique.
- Mounting hoses for the 3/8" hex head bolts. See figure 1.

Swing-Away (#63688)

Vehicle Requirement: Vehicle with 2" square Class III or Class IV hitch receiver.

Application: One man unloading of tilt bed vehicles with beds up to 96" wide.

- With a helper, lift the swing-away frame and slide the hitch bar into the vehicle receiver. Use proper lifting techniques.
- Secure with the hitch pin and the hairpin cotter. Attach the safety chain to the vehicle. Lift the debris loader unit and place it on top of the swing-away frame. Secure it to the frame with six (6) 3/8-16x1 bolts and six (6) 3/8-16 nylon insert flange nuts.
- To use the swing-away feature, pull the hitch pin on the right side and the lynch pin holding the frame together on the left side. Pull the swing-away frame open. The swing-away may be locked in the 90 degree or 180 degree positions with the hitch pin.

⚠WARNING

- DO NOT transport with the swing-away in either open position. Damage to the swing-away or vehicle may result.
- Close the swing-away and secure with lynch pin before transporting.

The swing-away may be used to vacuum debris in the 90 degree position.

The 180 degree position is for dumping the load of debris collected in the truck box. Before using the swing-away, conduct a trial run to be sure there is sufficient clearance between the debris loader and the truck body.

Installing the Discharge Chute to the Power Unit

Place the housing body (D) on a flat surface to keep it stable.

Install the discharge chute (E) to the housing by attaching Knob (A) through the spring washer (B) and Flat Washer (C). **See figure 2.** The chute's open direction can be adjusted during installation depending on the operation's needs.

Install the direction plate (F) to the chute with a screw nut and bolt. The knob can be used to adjust the discharge direction without a tool. **See figure 3.**

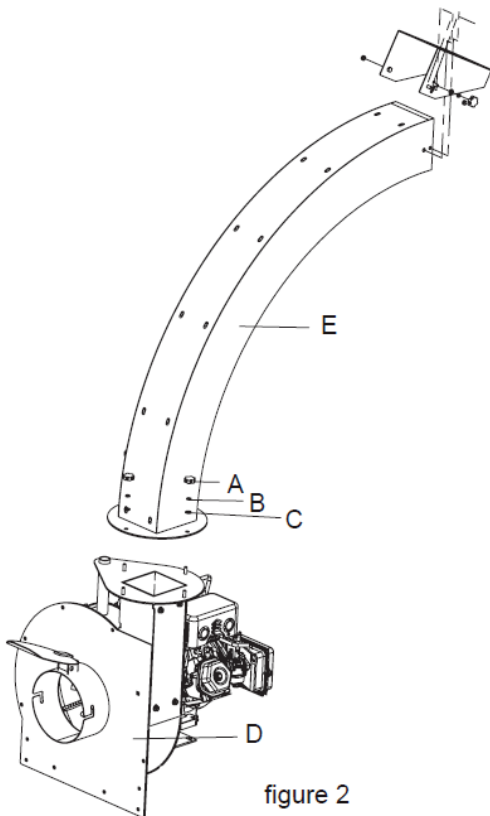

figure 2

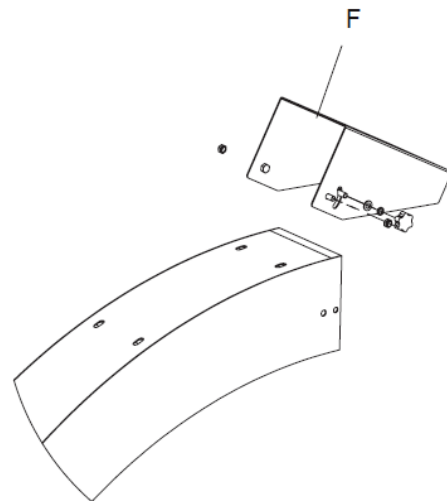

figure 3

Installing the Hose and Boom Arm to the Housing (see figure 4 for assembly)

1. Remove hose (A) from the box and stretch it.
2. Hold the hose, and stretch each end as far as possible to open the internal diameter.
2. Install the adapter (B) with the housing (E) by tightening the screw nut.
3. Insert one hose end with the hose adapter (B) by tightening the hose clamp (C).

4. Place hose bands (G) over the hose.
5. Place the boom arm (F) pivot shaft into housing tube.
6. Install the hose nozzle (D) or handle assembly, onto other end of the hose. Adjust the handle to the desired position and tighten the clamp.

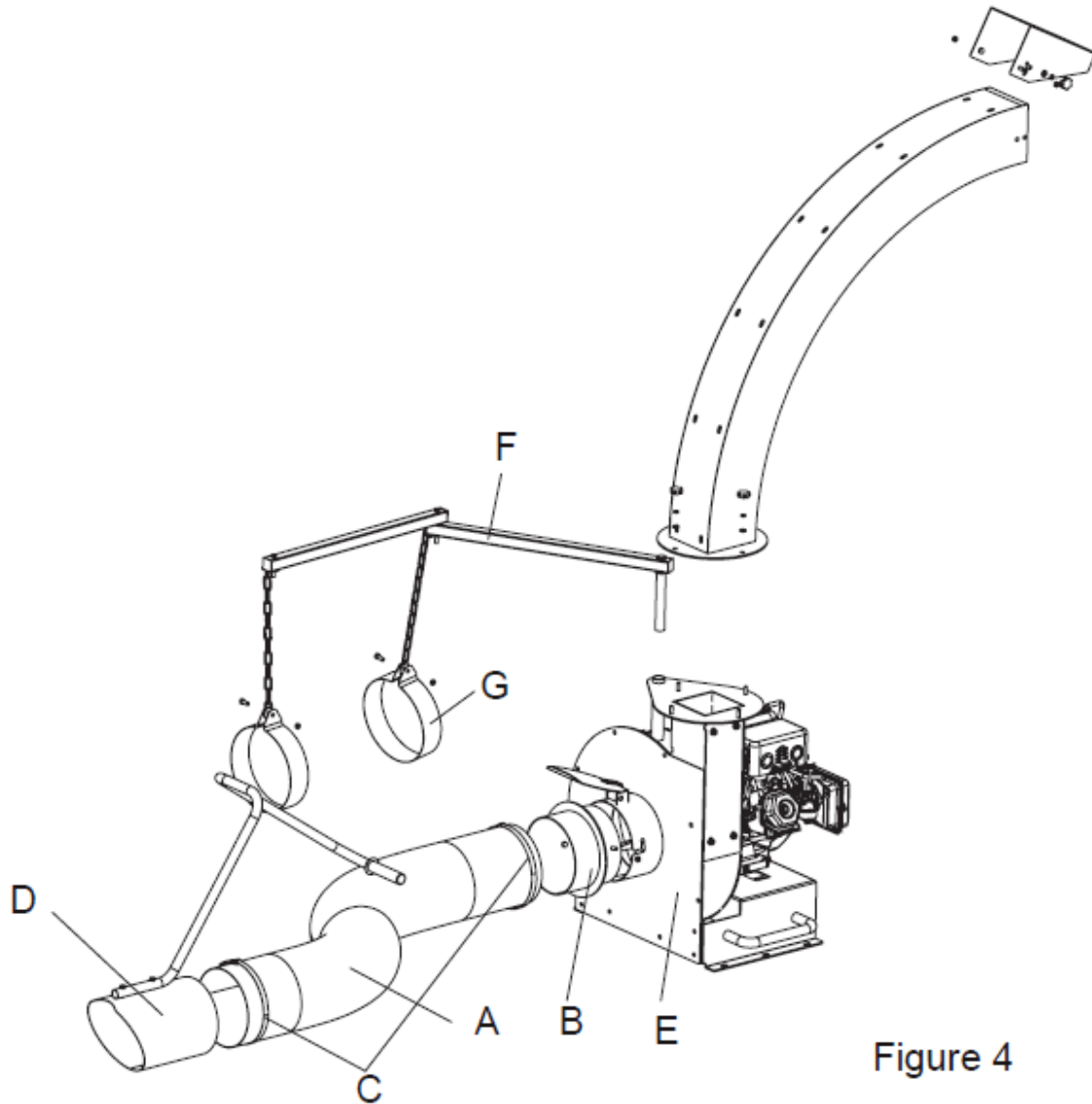

Figure 4

Before Each Use

⚠WARNING

- Inspect the unit for any signs of damage or foreign material in the machine. Remove any solid material that may be preventing the unit from operating properly.
- Be familiar with the controls, how each functions, and what each operates.
- Check engine oil level. Add oil if necessary, following the engine manufacturer's

recommendations. Refer to engine manual included with literature packet.

- Check the air cleaner for dirty, loose, or damaged parts. Clean or replace if necessary.
- Check the air intake and cooling area for dirt or debris and clean as necessary.
- Gasoline is extremely flammable and highly explosive under certain conditions. BE SURE to install fuel cap after refueling.
- Fill fuel tank with good quality, clean, unleaded regular gasoline to the level recommended by the engine manufacturer.

Operating Instructions

⚠WARNING

- Make sure that the machine is properly adjusted, set up correctly and the hose is empty before starting the machine.
- Never leave the machine running unattended. Always turn off the engine, wait for the impeller to come to a complete stop, and disconnect the spark plug before leaving the area. Always move the unit to a safe storage area when not in use.
- Do not feed metal, rocks, bottles, cans or any other non-botanical objects into the machine.
- Make sure the machine has come to a complete stop and disconnect the spark plug wire before freeing a jam or clog, emptying the bag, filling the gas tank, or performing any maintenance or repairs.
- Never direct discharge material toward anyone. Avoid discharging material against a wall or obstruction. Material may ricochet back toward the operator.
- Never attempt to reposition or move the debris loader unit while it is running. Doing so could cause the machine to tip over and cause unexpected injury.
- Check to be sure engine is free of dirt and debris. Pay particular attention to the cooling ins, governor parts and muffler. Clean air intake screen. Check air cleaner; service if necessary.
- Clean area around the oil fill dipstick. Remove dipstick and check to be sure oil is in operating range (between marks on dipstick). Add oil if necessary but Do Not Overfill. See engine manual for oil specifications. Install dipstick assembly firmly until cap bottoms out on tube. Dipstick assembly must always be secured into fill tube when engine is running.

Checking or Adding Fuel

1. Use a funnel to avoid spilling.
2. Add fuel outdoors.
3. Do not smoke.
4. Stop the engine; allow it to cool.
8. Do not overfill.
6. Clean up spilled fuel.

Starting the Engine

1. Turn the fuel on and move the throttle to the half-open position.
- 2 Set the engine switch to the ON or RUN position.
3. Move the choke to the ON position for cold starts. For warm starts, attempt to start without the choke first to avoid flooding. If the engine does not start then use the choke.
4. Pull the recoil starter handle firmly to start the engine.
5. When the engine starts, gradually back off the choke until the engine runs with no choke.

Operating

This machine has been designed for two methods of vacuuming debris:

1. With the handle of the intake nozzle in the operator's hands, move the nozzle back and forth in a sweeping motion over the debris.
2. Rotate the intake nozzle to lay sideways on the ground. By placing the nozzle in this position, debris can be raked into the nozzle by the operator. While large amounts of debris can be vacuumed quickly with this machine, caution must be taken to avoid blocking the airflow into the nozzle.

Stopping the Engine

When operation is complete, the unit needs to be checked, or a clog needs to be cleared:

1. Move the throttle to SLOW.
2. Set the engine switch to the OFF position.
3. Close the fuel valve.

Note: The impeller will continue to rotate for several seconds after the engine is stopped.

Excessive Vibration

Shut off the engine immediately if abnormal/excessive vibration occurs. Remove the spark plug wire. Find the cause of vibration and repair it. Some possible causes for excessive vibration are:

- Damaged impeller.
- Loose impeller bolt.
- Loose impeller key.
- Lodged objects.

Clogging

- To prevent clogs, do not overfeed, especially with heavy wet material.
- Pay attention to how full the debris receptacle is.
- Overfilled debris receptacles cause material to back up and get tightly packed in the discharge chute.

Removing Clogs

If a decrease in suction is experienced, there may be a debris blockage in the hose. Often a clogged hose can be cleared by stretching the hose out straight with the engine running. If the hose does not clear, you will need to remove the hose. Before removing the hose or attempting to clear a clog manually:

1. STOP the engine. Put the engine switch in the OFF position.
2. Wait for the impeller to come to a complete stop.
3. Disconnect the spark plug wires so impeller movement cannot accidentally start the engine.

⚠CAUTION

- Caution should be used when clearing truck loader from inside the housing.
- Gloves should be worn as sharp edges on the impeller or in the truck loader maybe preset.

4. Remove the hose assembly from the inlet flange assembly. With this removed, open the inlet flapper and remove any debris that is clogging the housing.
5. Remove the discharge chute from the transition discharge tube's flange.
6. With the chute removed, inspect the transition discharge part of the housing and remove any debris clogging this area.
7. Reassemble removed parts and reconnect the spark plug wire. Resume operation.

After Each Use

⚠WARNING

- Stop the engine and allow cooling before storing.
- Do not store the machine near heating appliances with an open flame such as a water heater or an appliance with a pilot light.
- Clean grass and debris from cutting units, drives, mufflers and engine to help prevent fires.
- When not in use, store indoors in a sheltered area (a dry place) where it is not accessible to children.
- DO NOT store in a house.
- Keep throttle in SLOW position and switch in the OFF position.

Transporting

1. Shut off the engine and turn off the fuel valve.
2. Disconnect the hose from the power unit.
3. Remove the boom assembly from the frame (it can stay with the hose.)
4. Remove the discharge chute.
5. Transport the hose/boom assembly and discharge chute secured in the truck or trailer.
6. Do not exceed 30 mph. High speeds together with rough roads can cause damage to the unit.

Engine Oil

1. Check the oil level daily.
2. Change the oil after the first day of operation and then according to the engine manual.
3. See the engine manual for oil specifications and checking procedure.

Engine Air Cleaner

1. Check and clean according to the engine manuals.
2. Daily inspection and cleaning is recommended due to the extreme environment of debris handling.

Cleaning

Keep the area around the muffler and engine recoil cover/cooling air intake free of debris accumulation to prevent fires and keep the engine from overheating. These areas need to be monitored throughout the work day and may need to be cleaned several times daily depending on circumstances.

Housing Liner Replacement

1. Before replacing liner, stop engine.
2. Turn engine switch to the OFF position.
3. Remove the spark plug wire so fan movement cannot inadvertently start engine.
4. Remove hose from blower inlet.
5. Remove nuts securing blower inlet assembly and open blower inlet assembly.
6. Remove liner retainer.
7. Remove the old liner.
8. Install the new liner with the thick rubber side towards the fan. Use new bolts and washers.
9. Start at one end and work around the housing leaving the fasteners loose until all the fasteners have been installed. Then tighten the bolts until the washer is slightly drawn into the rubber. Do not over tighten.
10. Reinstall liner retainer. See parts list for locations of carriage bolts.

Chute Liner Replacement

1. Before replacing liner, stop engine.
2. Turn the engine switch to the OFF position.
3. Remove the spark plug wire so fan movement cannot inadvertently start engine.
4. Remove chute from blower housing.

5. Remove rubber plugs from access holes on the bottom of the chute.
6. Remove nuts, washers, and bolts then remove old liner.
7. Feed the new liner into the chute. Using new bolts and washers on the inside, and new washers and nuts on the outside, install new fasteners working in from each end. Leave the bolts loose until all fasteners are installed. Tighten the nuts and bolts, working from the inside out.
8. Reinstall the rubber plugs.
9. Reinstall the chute on the machine.

Maintenance

⚠WARNING

- To prevent possible explosion or ignition of vaporized fuel, do not store equipment with fuel in tank or carburetor in an enclosure or enclosed area with an open flame (for example, a furnace or water heater pilot light).

Before the equipment is put into storage for any period exceeding 30 days, the following steps should be completed:

- Drain all fuel from the fuel tank and the fuel lines. Drained fuel may only be stored for 30 days. If a stabilizer is chosen, follow the manufacturer's recommendation by adding the correct amount of additive for the amount of fuel to be stored. Fill the tank with this clean, fresh gasoline and run the engine for 2 to 3 minutes to get the stabilized fuel into the carburetor.
- Start the engine and run until all the fuel is used from the carburetor float bowl and the engine stops.
- While the engine is still warm, drain the crankcase oil and replace with the proper weight oil corresponding to the season the equipment will be used next.
- Remove the spark plug and squirt a small amount of engine oil into the cylinder. Reinstall the plugs and ground spark plug leads- DO NOT connect the leads to the plugs. Crank the engine two or three revolutions.
- Store the unit and all of its components in a clean, dry, well ventilated, non-child accessible, sheltered area that is out of sun light and high ambient temperatures.

To put the equipment into service after an extended period of storage:

- Check for loose parts and tighten if necessary.
- Fill the fuel tank and then check the engine oil level. Top off if necessary. See engine manual for details.
- Start the engine and check for fuel leaks. Repair any leaks before operating the unit.

Troubleshooting

⚠WARNING

- Turn OFF the machine, allow all moving parts to come to a complete stop, and disconnect the spark plug wire before moving the machine, emptying the bag, unclogging the inlets or outlets, filling the gas tank, or performing maintenance and repairs.

Problem(s)	Possible Cause	Corrective Action
Engine won't start	No fuel.	Add fuel.
	Choke not in the START position.	Turn choke to the START position.
	Low quality or old gasoline.	Use fresh unleaded gasoline.
	Dirty fuel passageways.	Clean out passageways using fuel additive. Heavy deposits may require further cleaning.
	Spark plug cap not connected securely.	Connect spark plug cap properly.
	Spark plug fouled.	Remove spark plug. Clean/replace as recommended in engine manual.
	No compressions. Problems after long storage periods.	Lubricate the cylinder, pour tablespoon of oil into spark plug hole. Crank engine a few times and try to start again.
	Low engine oil.	Add engine oil to proper level.
Engine exhaust is black	Dirty air filter.	Replace air filter.
	Choke closed.	Open choke.
Engine stops suddenly	Fuel tank empty or using old or low quality gasoline.	Add fuel tank with fresh unleaded gasoline.
	Low oil shut-down.	Fill engine oil to proper level.
	Disconnected or improperly connected spark plug cap.	Secure spark plug cap.
Engine runs but no material is discharged	Discharge chute clogged.	Clean out debris.
	Engine not running at full speed.	Set throttle control to FAST if equipped.
Vacuum not working	Hose not attached properly.	Clear blockage or replace.
	Engine not running at full RPM.	Set throttle control to FAST if equipped.

Parts Diagram

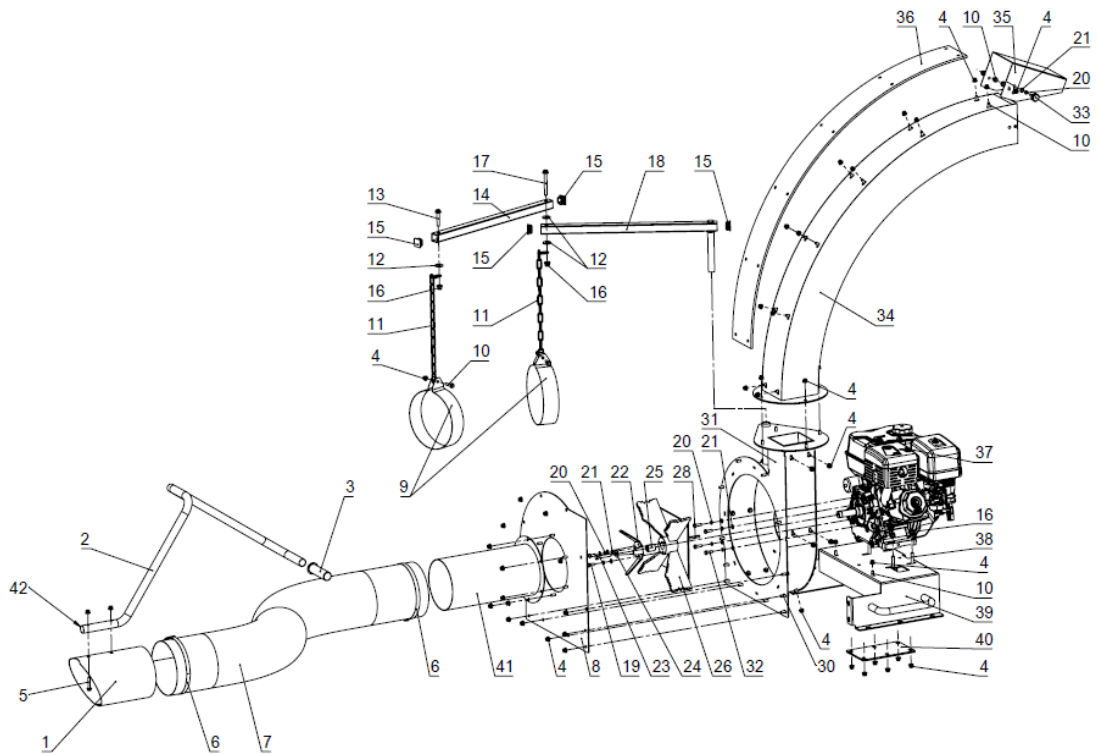

Parts List

Part No.	Description	Quantity	Part No.	Description	Quantity
1	Nozzle	1	23	Bolt	1
2	Handle	2	24	Spring Washer	1
3	Handle Sleeve	2	25	Stopper	1
4	Screw Nut M8	40	26	Impeller	1
5	Bolt M8x40	2	27	Screw	2
6	Hose Clamp	2	28	Engine Flat Key	1
7	Hose	1	29	Bearing Sleeve	1
8	House Cover	1	30	Bolt M8x25	4
9	Hose Band	2	31	Housing	1
10	Bolt M8x20	33	32	Bolt	4
11	Chain	2	33	Hand Wheel	5
12	Washer	4	34	Discharge Chute	1
13	Bolt M10x55	1	35	Direction Plate	1
14	Boom Arm	1	36	Discharge Liner	1
15	End Cap	4	37	Engine	1
16	Screw nut M10	6	38	Bolt M10x40	1
17	Bolt M10 x 90	1	39	Engine Base	1
18	Boom Mast	1	40	Base Plate	2
19	Bolt M8x25	3	41	Hose Adapter	1
20	Spring Washer	12	42	End Cap	1
21	Flat Washer	12			
22	Knife	1			

--	--	--	--	--	--	--

Replacement Parts

- For replacement parts and technical questions, please call Customer Service at **1-800-222-5381**.
- Not all product components are available for replacement. The illustrations provided are a convenient reference to the location and position of parts in the assembly sequence.
- When ordering parts, the following information will be required: item description, item model number, item serial number/item lot date code, and the replacement part reference number.
- The distributor reserves the rights to make design changes and improvements to product lines and manuals without notice.

Limited Warranty

Northern Tool and Equipment Company, Inc. ("We" or "Us") warrants to the original purchaser only ("You" or "Your") that the Powerhorse product purchased will be free from material defects in both materials and workmanship, normal wear and tear excepted, for a period of two years from date of purchase. The foregoing warranty is valid only if the installation and use of the product is strictly in accordance with product instructions. There are no other warranties, express or implied, including the warranty of merchantability or fitness for a particular purpose. If the product does not comply with this limited warranty, Your sole and exclusive remedy is that We will, at our sole option and within a commercially reasonable time, either replace the product or product component without charge to You or refund the purchase price (less shipping). This limited warranty is not transferable.

Limitations on the Warranty

This limited warranty does not cover: (a) normal wear and tear; (b) damage through abuse, neglect, misuse, or as a result of any accident or in any other manner; (c) damage from misapplication, overloading, or improper installation; (d) improper maintenance and repair; and (e) product alteration in any manner by anyone other than Us, with the sole exception of alterations made pursuant to product instructions and in a workmanlike manner.

Obligations of Purchaser

You must retain Your product purchase receipt to verify date of purchase and that You are the original purchaser. To make a warranty claim, contact Us at 1-800-222-5381, identify the product by make and model number, and follow the claim instructions that will be provided. The product and the purchase receipt must be provided to Us in order to process Your warranty claim. Any returned product that is replaced or refunded by Us becomes our property. You will be responsible for return shipping costs or costs related to Your return visit to a retail store.

Remedy Limits

Product replacement or a refund of the purchase price is Your sole remedy under this limited warranty or any other warranty related to the product. We shall not be liable for: service or labor charges or damage to Your property incurred in removing or replacing the product; any damages, including, without limitation, damages to tangible personal property or personal injury, related to Your improper use, installation, or maintenance of the product or product component; or any indirect, incidental or consequential damages of any kind for any reason.

Assumption of Risk

You acknowledge and agree that any use of the product for any purpose other than the specified use(s) stated in the product instructions is at Your own risk.

Governing Law

This limited warranty gives You specific legal rights, and You also may have other rights which vary from state to state. Some states do not allow limitations or exclusions on implied warranties or incidental or consequential damages, so the above limitations may not apply to You. This limited warranty is governed by the laws of the State of Minnesota, without regard to rules pertaining to conflicts of law. The state courts located in Dakota County, Minnesota shall have exclusive jurisdiction for any disputes relating to this warranty.



POWERHORSE[®]

Distributed by:

Northern Tool & Equipment Company, Inc.

Burnsville, Minnesota 55306

www.northerntool.com

Made in China